

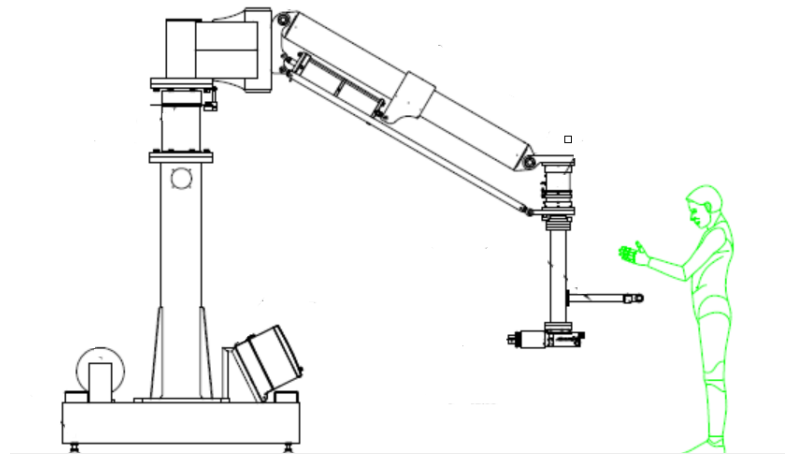

Arms and Fixtures

Application Manual

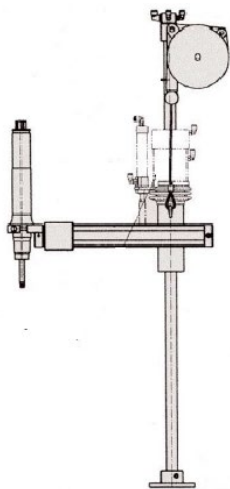

10000 SE Pine St., Portland, OR 97216 • 503-254-6600 • 800-852-1368

www.aimco-global.com

Table of Contents

- 1 Articulating Torque Arm**..... 1
 - 1.2 Remote start**..... 3
- 2 Carbon Arms**..... 4
 - 2.2 Balancer Geometry** 5
- 3 Torque Tubes** 6
- 4 Ergo Arms** 8
- 5 Linear Quick Arm** 10
- 6 Ergo Arm 3**..... 11
- 7 Carts with Jib** 14
- 8 Reaction Bars** 15
- 9 Nose Extensions** 17
- 10 Balancers**..... 19
- 11 Recommended Tool Mounting Points**..... 20
- 12 Safety Information** 26

Feature	Articulating Torque Arm	Carbon Arm	Torque Tube	Ergo Arm	Linear Quick Arm	Ergo Arm 3	Cart w/Jib	Reaction Bars	Nose Ext.	Balancer
Cost		X		X			X	X	X	X
Weight Management	X	X	X	X	X	X	X			X
Resolve torque	X	X	X	X	X			X	X	
Tool Orientation	X	X	X	X	X	X				
Torque range (Nm)	75 - 10000	10 - 1000	10 - 1000	0.2 - 12	0.5 - 28	60 - 600	60 - 8100	4-8100	200 - 8100	1 - 8100
Angle Tools	X	X	X			X	X			X
Straight Tools	X	X	X	X	X		X	X	X	X
Pistol Tools	X	X		X	X	X	X	X	X	X
Continuous Drive tools	X	X	X	X	X	X	X	X	X	X
Discontinuous Drive tools						X	X			X
Multi-spindle	X		X			X	X	X		X

1 Articulating Torque Arm

Articulating Torque Arms provide high torque resolving capacity, durability, seamless tool integration and all-around performance. Engineered and built based on ergonomic fundamentals, the arms absorb and react all torque output preventing operator strain, fatigue, and injury.

.....

Why choose this type of arm:

- Resolves torque reaction
- Provides weight management.
- Multiple tool orientations.
- Mobile versions available.
- Available for Single or Multi Spindle applications.



Torque limit: 10-10,000 Nm.

Ways of arm mounting:

- Floor
 - Stationary
 - Mobile
- Bench mount
- Wall
- Overhead
 - Fixed
 - Trolley

Advantages:

- Can resolve high torque reaction
- Custom designed for application
- Many configurations possible

Disadvantages:

- Requires more space
- Cost is higher than other types of arms

End Effectors:

The end effector to the tool is most often custom and will be determined when tool type is chosen.

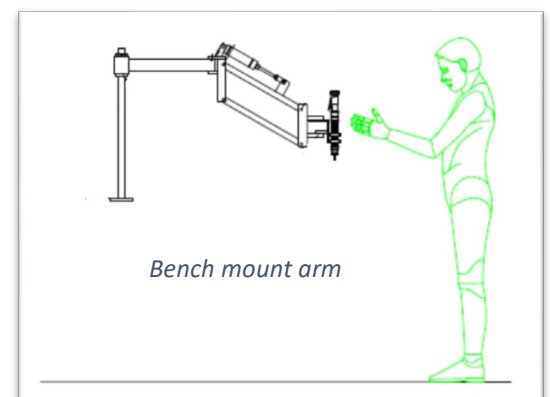
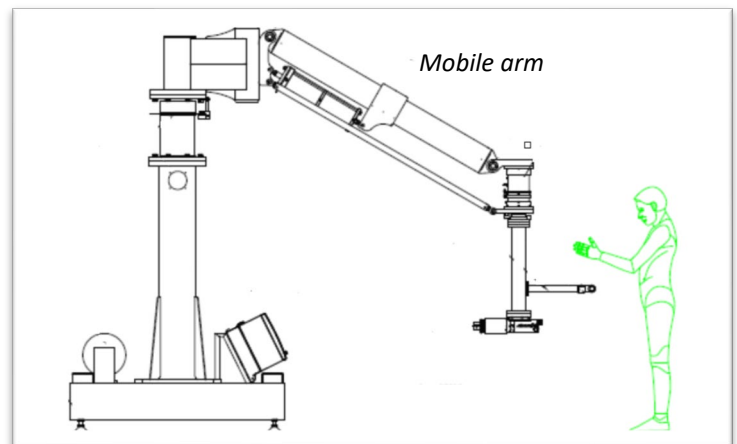

Examples:

Floor Mount



AcraDyne 5000 series right angle tool in torque arm

Overhead Mount



AcraDyne H/T tool w/ offset geared head in torque arm



Tools recommended for use with this arm:

AcraDyne 3000-8000 Series HT tools

- Straight (AES)
- Pistol (AEP)
- Axial (AEJ)
- Angle (AEN 5000 series only)
- Fixtured (AEF)

1.2 Remote start



Compatible with any AcraDyne DC tool.
 (Required for AcraDyne AEF Fixtured tools)

Available Options for arms (Not Included in Quote Unless Specifically Noted)

<u>Arm System Options</u>
Low Pressure Warning Whistle
Adjustable Main Rotation Stop
Adjustable Articulating Joint Stop
Third Axis Parking Brake
Independent Brake Toggles
High Load Parking Brakes
Single Passage 360° Air Union (main rotation only)
Paint Color Other Than standard safety Yellow
Carbon Fiber Arm Painted
Carbon Fiber with Visible Weave
Home Proximity Sensors (2 axis)
Portable Base
Foundation Plate
Assisted Install or After Install Inspection
PM Inspection
<u>Material Handling Arms (arm system options plus)</u>
Electric Load Sensor
Pneumatic Load Sensor
Tool Changer (multiple tools on one arm)
<u>Torque Arms (arm system options plus)</u>
DC Remote Start
Brake Engagement Verification Circuit (requires remote start)
Dual Balance Control (up or down bias)
Socket Tray Mount
Pneumatic Tool Start Button
Secondary Fixed Handle
Smart Arm
Mounting for non-supplied Computer
Red/Green/Yellow External Light for Smart Arm

2 Carbon Arms

Carbon Torque Arms are light weight, provide smooth assembly operation and comfort since the arm is absorbing the torque reaction generated by the tool. The telescoping design allows maximum freedom of movement and flexibility.

.....

Why choose this type of arm:

- Resolves Torque.
- Weight management (when using balancer)
- Cost savings
- Multiple tool orientations

Torque limit: 10-1,000 Nm

Ways of arm mounting:

- Bench
- Wall
- Overhead

Advantages:

- Easy to Use
- No maintenance
- Low cost

Disadvantages:

- Dependent on orientation of tool to work piece
- External balancer required for certain arms
- Work area dependent on arm length

End Effectors:

Many types of tool connector are available please see AIMCO Assembly Tool Catalog

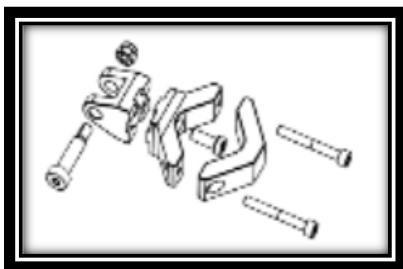

Examples:

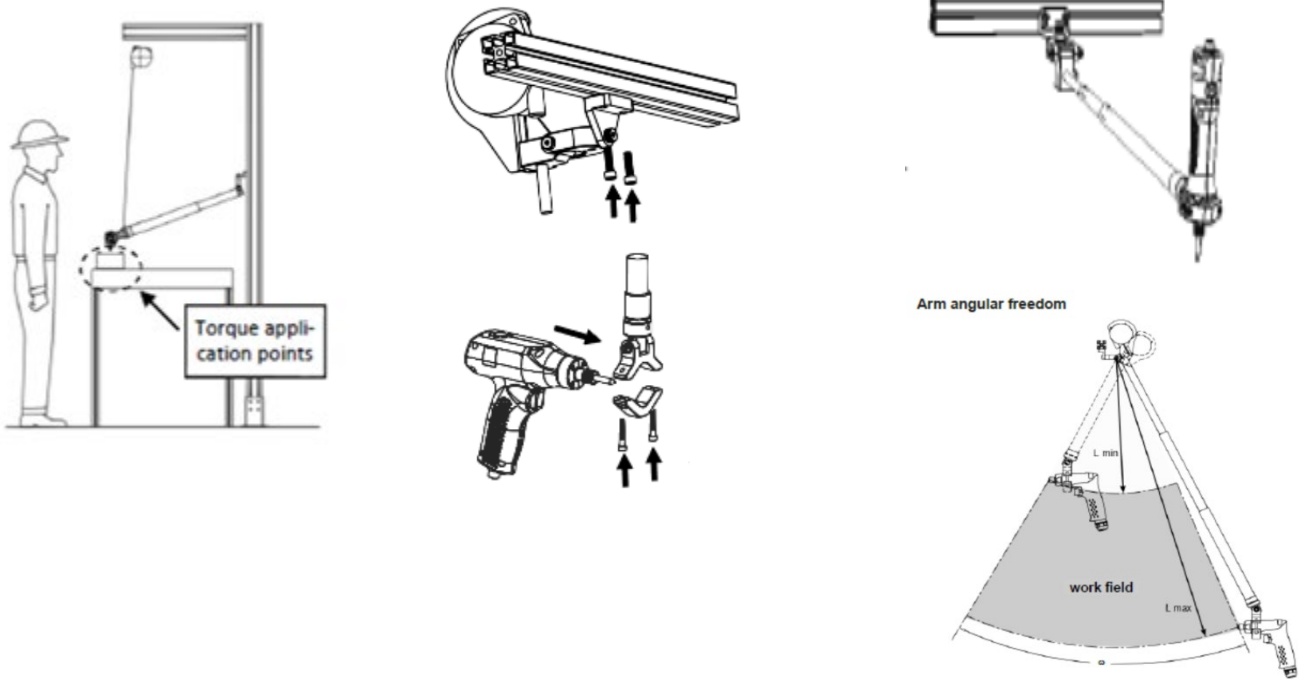

Tools recommended for use with this arm:

- AcraDyne
 - 1000/2000/3000 AEN Series angle tools. 4-200 Nm range
 - 1000/ 2000 AEP Series pistol tools. 3-40 Nm range
 - 6000/7000 Series H/T tools to 1,000 Nm
- UAN Series Nut runner

2.2 Balancer Geometry

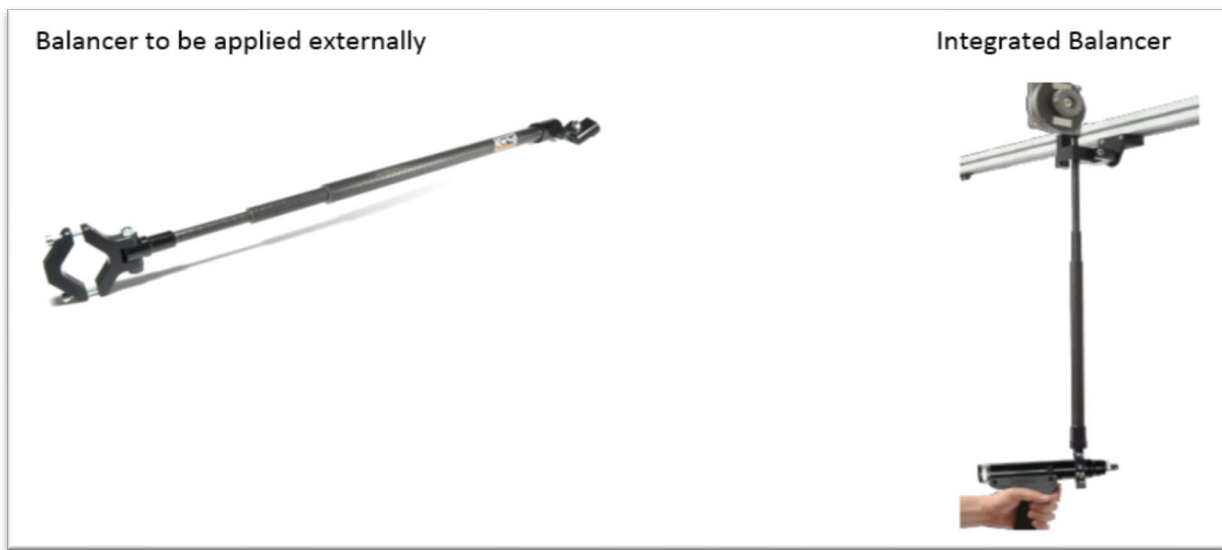

3 Torque Tubes

Torque Tubes are designed to reduce operator fatigue by absorbing torque reaction produced by assembly tools while balancing the tool weight. Torque Tubes use a pneumatic cylinder or a spring balancer to achieve zero gravity balancing.

.....

Why choose this type of arm:

- Weight Management
- Resolve Torque
- Provides redundant safety in 2 spindle systems

Torque limit: 10-1,000 Nm

Ways of arm mounting:

- Overhead

Advantages:

- Ideal for overhead applications
- Smooth vertical travel
- Lower cost than articulating torque arms
- All utilities overhead helps maintain clean work area

Disadvantages:

- Requires sufficient overhead structure
- Requires separate air line

End Effectors:



TOOL MOUNTING OPTIONS

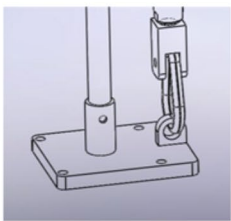

SQUARE PLATE

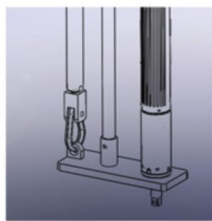

VERTICAL TOOL

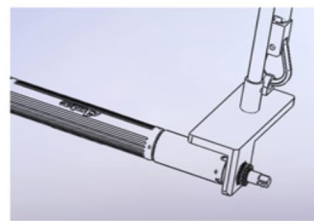

HORIZONTAL TOOL

Examples:

Straight tool in torque tube

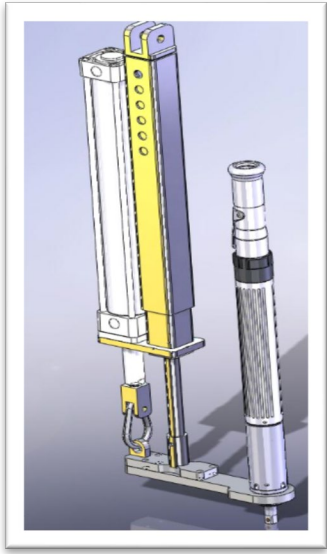

Right angle tool in torque tube mounted to trolley

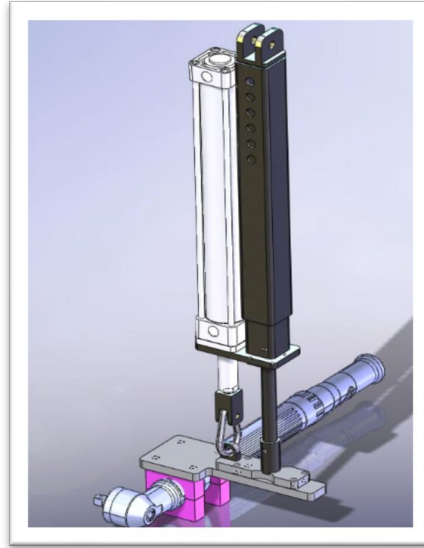

Straight tool, trolley and Torque tube

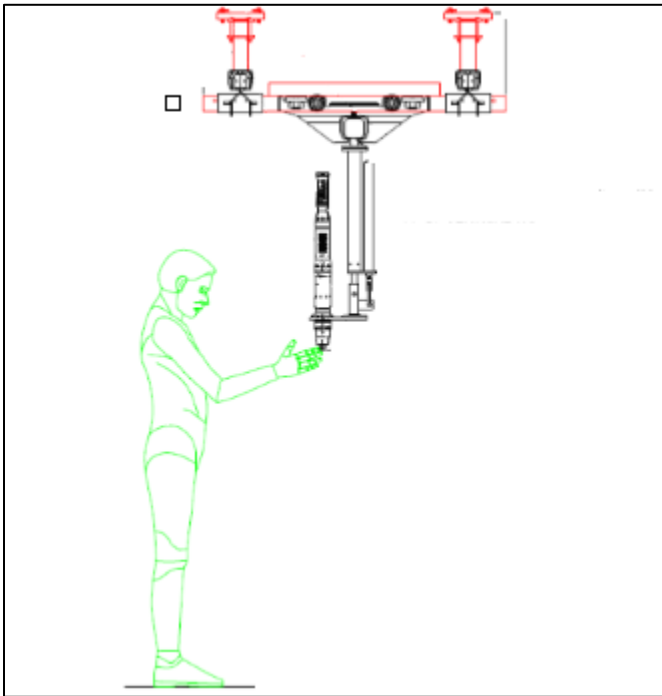

Angle tool in torque tube w/rotating tool mount

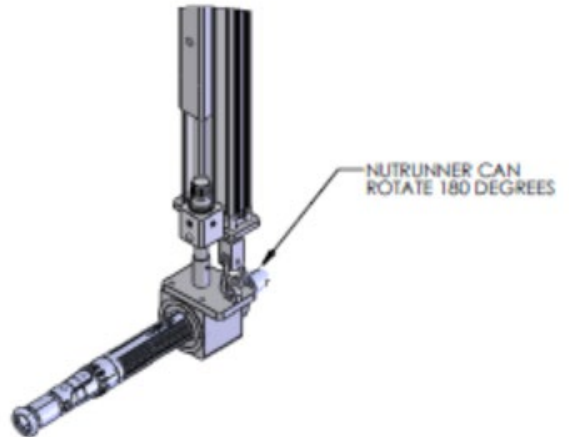

Tools recommended for use with this arm:

- AcraDyne
 - 3000-8000 series AES in-line tools (all tool configurations are possible though)

4 Ergo Arms

Ergo Arm Series torque reaction arms are designed to absorb torque transfer from the tool to the operator. Optional tool mounts are available for pistol grip, and angle style tools. They are available in single or parallel configurations. Parallel configurations maintain tool perpendicularity to the work piece throughout tool travel.

.....

Why choose this type of arm:

- Cost
- Resolve Torque
- Multiple tool orientations



Torque limit: .5-12 Nm

Ways of arm mounting:

- Bench mount
- Wall mount

Advantages:

- Ideal for lower torque applications.
- Easy setup
- Reduce operator fatigue.

Disadvantages:

- Not available for high torque applications.
- Best suited for pneumatic tools

End Effectors:

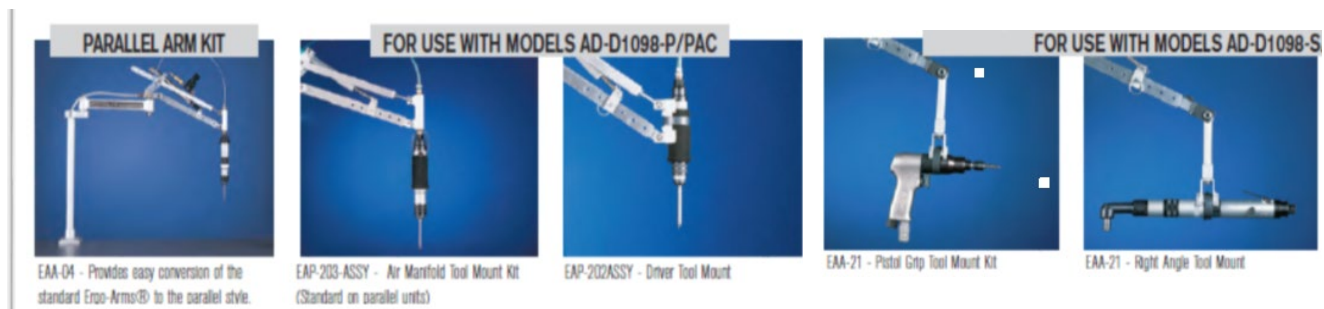

Examples:

Straight US-LT series screwdriver mounted to

AD-D1098-SAC Ergo Arm



Straight US-LT series screwdriver mounted to

AD-D1098-PAC Ergo Arm



Tools recommended for use with this arm:

- US-LT Series
 - Angle
 - In-line
 - Pistol
- Omega 30/40 series pulse tools to 110 "lbs."
 - Angle
 - In-line
 - Pistol

5 Linear Quick Arm

Linear Quick Arms are compact bench mounted devices featuring precision ground rails and high quality roller bearings for smooth travel during use. Counterbalanced with spring balancers to handle a wide variety of tool payload weights.

Why choose this type of arm:

- Resolve torque
- Weight management
- Ideal for lower torque applications.

Torque limit: .5-28 Nm

Ways of arm mounting:

- Bench mount

Advantages:

- Smooth movement and balance
- Prevents side load and reduces cross threading
- Reduces RMI (Repetitive Motion Injury) and CTS (Carpal Tunnel Syndrome)

Disadvantages:

- Restricts operator movement

End Effectors:

Tools recommended for use with this arm:

- AcraDyne 1000 series tools
- US-LT Series
 - Angle
 - In-line
 - Pistol
- Omega series pulse tools
 - Angle
 - In-line
 - Pistol
- AE Series electric Screwdrivers
 - In-line

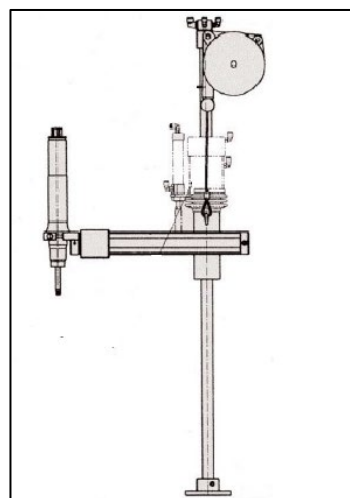
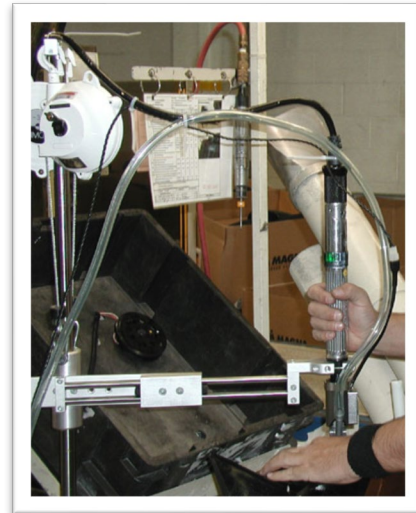

6 Ergo Arm 3

Ergo Arm 3 provides a Zero Gravity handling capability for a wide variety of tools. Arms are able to be configured in a variety of mounts, tool end effectors and tool orientation requirements. Wherever operator fatigue, employee safety, productivity, or tool management are a concern.

.....

Why choose this type of arm:

- Weight Management
- Tool orientation

Torque Limit: 60-600 Nm

Ways of arm mounting

- Bench
- Overhead
- Wall



Advantages:

- Zero gravity
- Reduce operator fatigue

Disadvantages:

- Does not resolve torque (Weight management only)

End Effectors:

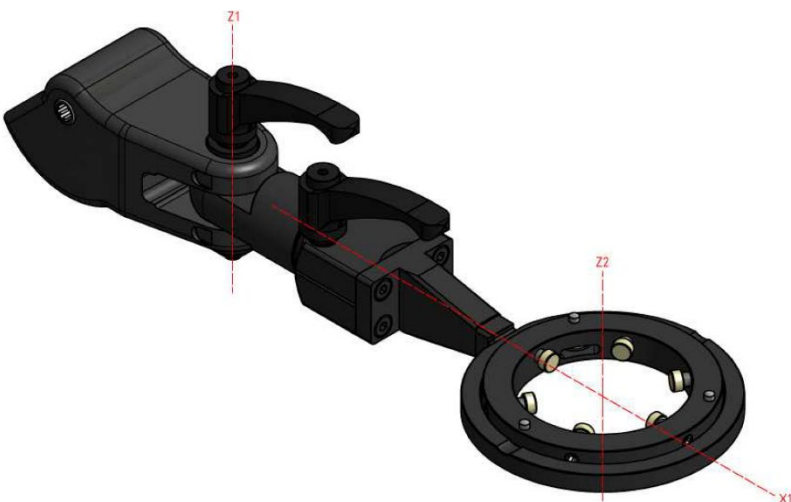

X1: Turns 360 degrees, lockable

Z1: Turns 90 degrees right/left and lockable







Z2: Turns 360 degrees non-lockable

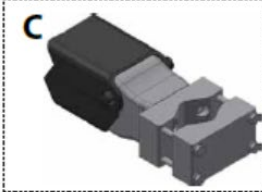

- X1: 360 degrees locking
- X2: 360 degrees non- locking
- Y: 360 degrees non- locking
- Z1: 90 degrees left/right non- locking
- Z2: 360 degrees non- locking

Many different types of end effectors available:

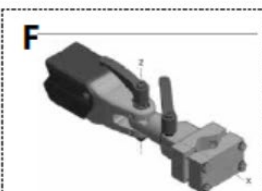
Head members

 <p>A</p> <p>Tilting arm movement only</p>	 <p>B</p> <p>Tilting arm movement only</p>	 <p>C</p> <p>Tilting arm movement only</p>	 <p>D</p> <p>X: Turns 360° Z: Turns 90° right & left. Lockable in any position</p>
 <p>E</p> <p>X: Turns 360°. Lockable in any position Z: Turns 90° right & left. Lockable in any position</p>	 <p>F</p> <p>X: Turns 360°. Lockable in any position Z: Turns 90° right & left. Lockable in any position</p>	 <p>G, H</p> <p>G: from 0 up to 15 kg/33 lbs with Quick Change X1: Turns 360°. Lockable each 45° X2: Turns 360° Y: Turns 360° Z1: Turns 90 right & left Z2: Turns 360°. Non lockable</p> <p>H: from 15 kg/33 lbs up to 30 kg/66 lbs. NO Quick Change X: turns 360°. Lockable in any position Y: Turns 360°. Lockable in any position Z1: Turns 90° right & left Z2: Turns 360°</p>	

Engineered for your application
Over 600 standard combinations available

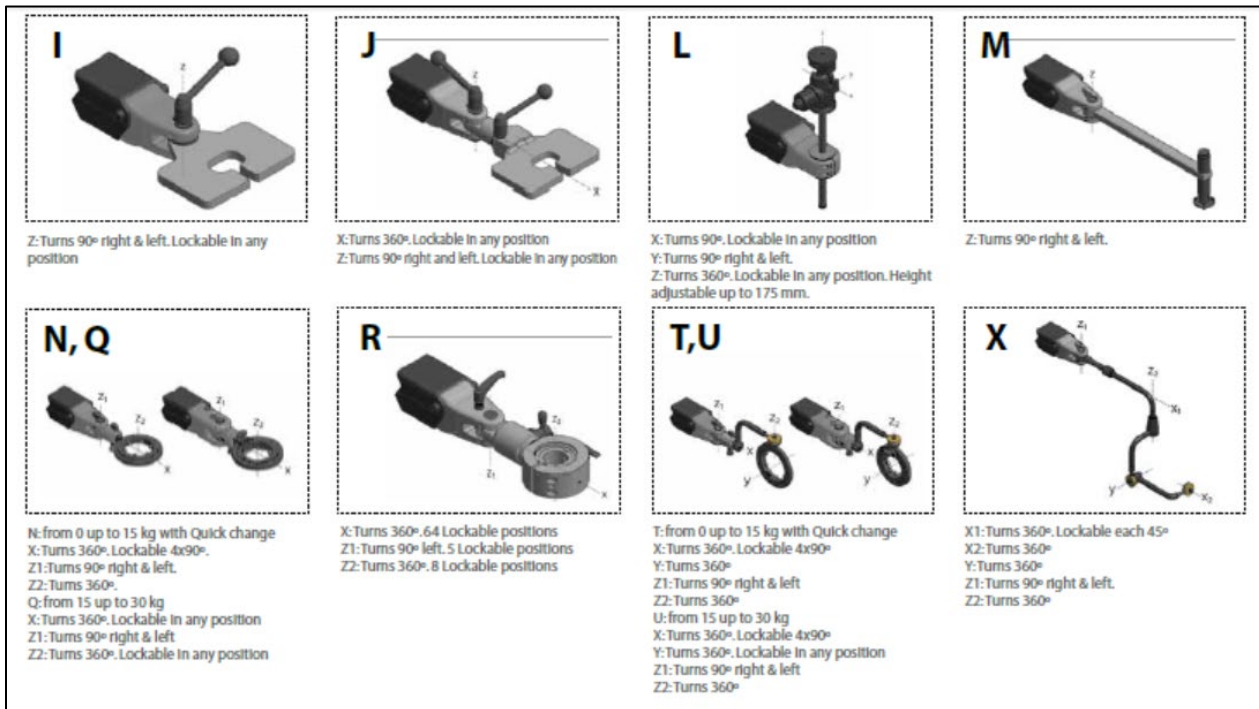

Examples:



Tools recommended for use with this arm:

- UXR/ULT/UAT series pulse tools
- UW series impact wrenches
- UAN series angle nut runner

7 Carts with Jib

Ideal for use in applications where mobility of jib and maximum utilization of floor space is desired.

.....

Why choose this type of arm:

- Weight management
- Mobile
- Alternative to higher cost articulating torque arms

Torque limit: 60-8,100 Nm

Ways of arm mounting

- Mobile cart

Advantages:

- Multiple tool orientations possible
- Portable
- Can be used with low cost multiple

Disadvantages:

- Requires torque to be resolve at application

Examples:

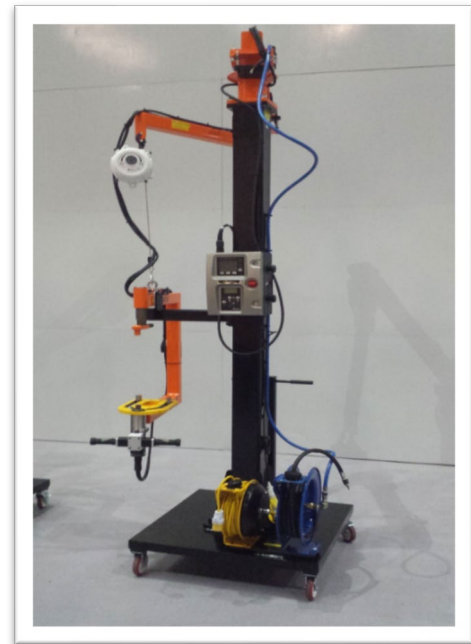

Trombone assembly on mobile cart

Tools recommended for use with this arm:

- Omega/UXR Series pulse tools
- AcraDyne DC tools with reaction bar
- UAN series angle nut runners
- AcraDyne HT tool with nose extension or reaction bar

8 Reaction Bars

When utilizing assembly tools on high torque applications, it is ***extremely important*** to consider the issues of torque reaction. Reaction forces are generated by the tool in use and will impact both the tool, operator and part where torque is being applied. Correct reaction bar geometry is critical when configuring the process.

.....

Torque limit: 4-8100 Nm

Why choose a reaction bar:

- Lower cost alternative to Torque reaction arm

Ways of mounting reaction bar:

- Always mount spline/hex at the end of the tool

Advantages:

- Can be used in tight access applications
- Portability

Disadvantages:

- Possible operator injury do to reaction forces
- Possible parts damage

Examples:

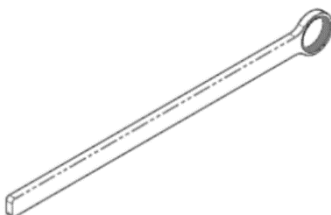
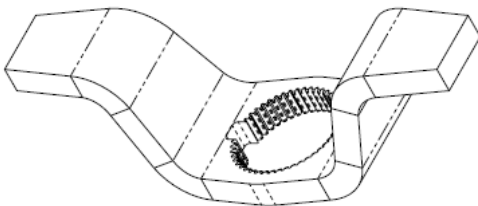

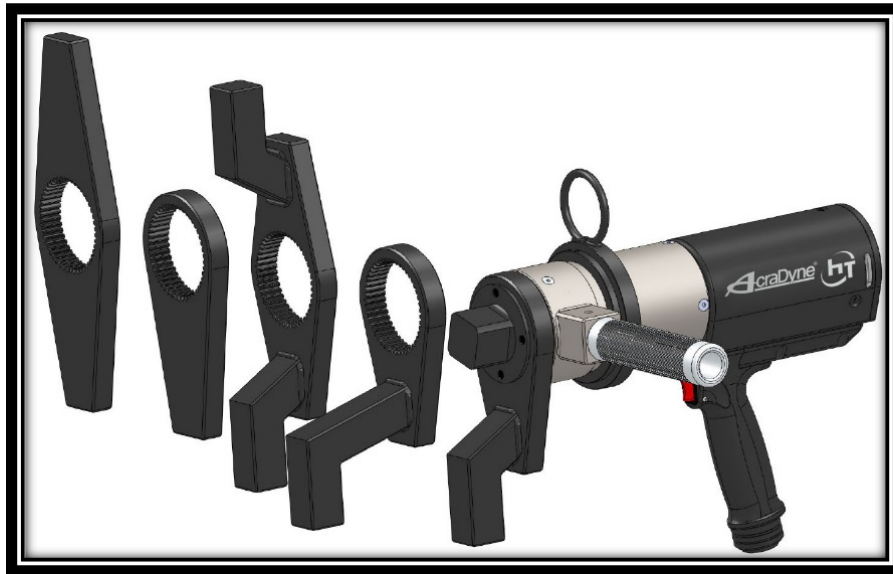

Tools recommended for use with reaction bars:

- All 1000 thru 8000 series AcraDyne HT tools.

9 Nose Extensions

Special nose extension reaction devices are available for use in situations where the tool access is restricted. A typical application are wheel nuts on heavy vehicles.

Why choose a nose extension:

- Alternative to multi-spindle
- Resolve torque reaction

Torque limit: 200-8100 Nm

Advantages:

- Lower cost alternative to multi spindles
- No torque arm required
- Ideal for tight access applications

Disadvantages:

- Results in higher tool weight with nose extension installed
- Application specific

Examples:

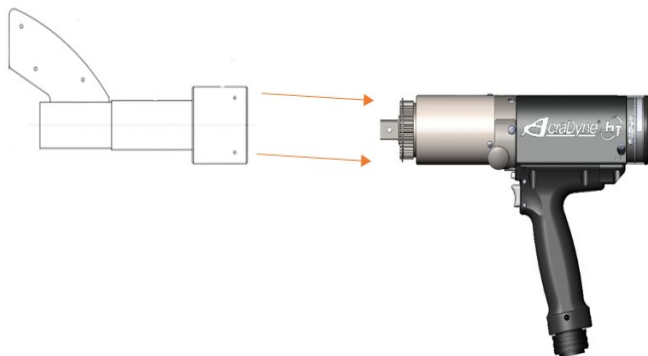
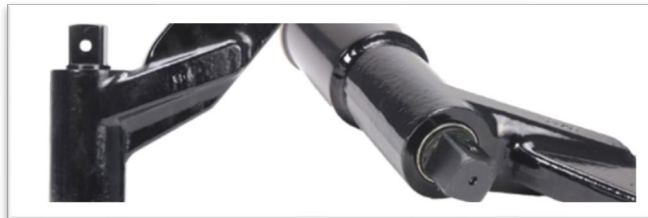
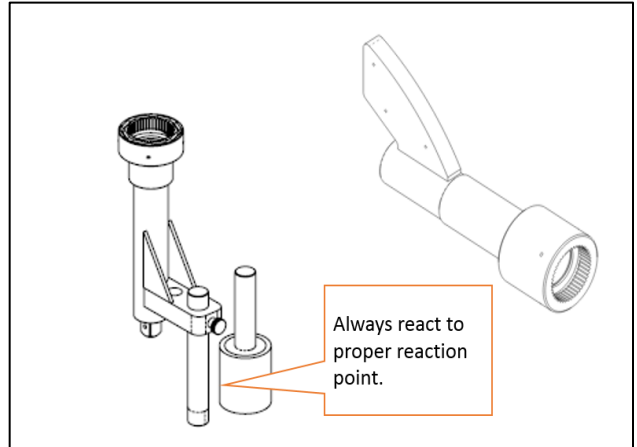

Wheel Nut install with AcraDyne HT tool and nose extension



AcraDyne® HT

10 Balancers

Balancers are for applications where a constant weight travels a relatively short vertical distance (i.e. power tools, assembly tools). These balancers cover weights 1.1 to 154 lbs.

Why choose a balancer:

- Weight management
- Zero gravity

Torque range: 1.1-8,100 Nm

Advantages:

- Gravity defying “true balance”
- Reduce worker fatigue

Disadvantages:

- Will not resolve torque reaction

Examples:

TW-22 spring balancer

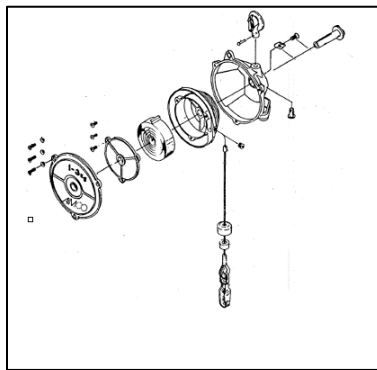

11 Recommended Tool Mounting Points

All Standard-Series AcraDyne tools have a reaction transducer that couples the gearing to the output by use of a floating ring gear. It is imperative that the transducer & ring gear float freely inside of the gearcase housing when the tool is fixtured. If the gear case housing is stressed sufficiently, the transducer may not be able to operate properly and inaccurate results will be reported.

.....

11.1 Standard-Series AcraDyne tools

Angle Tools:

- Fixture to tool as far away from the anglehead as is practical. This lowers the point stresses by creating a longer moment arm.
- Near a hard point like where two sections of the tool are connected together.
- On the Steel Section - The aluminum connections are not designed to resolve the torque after the multiplier
- Know where the transducer is and AVOID IT.

AcraDyne Transducer Design

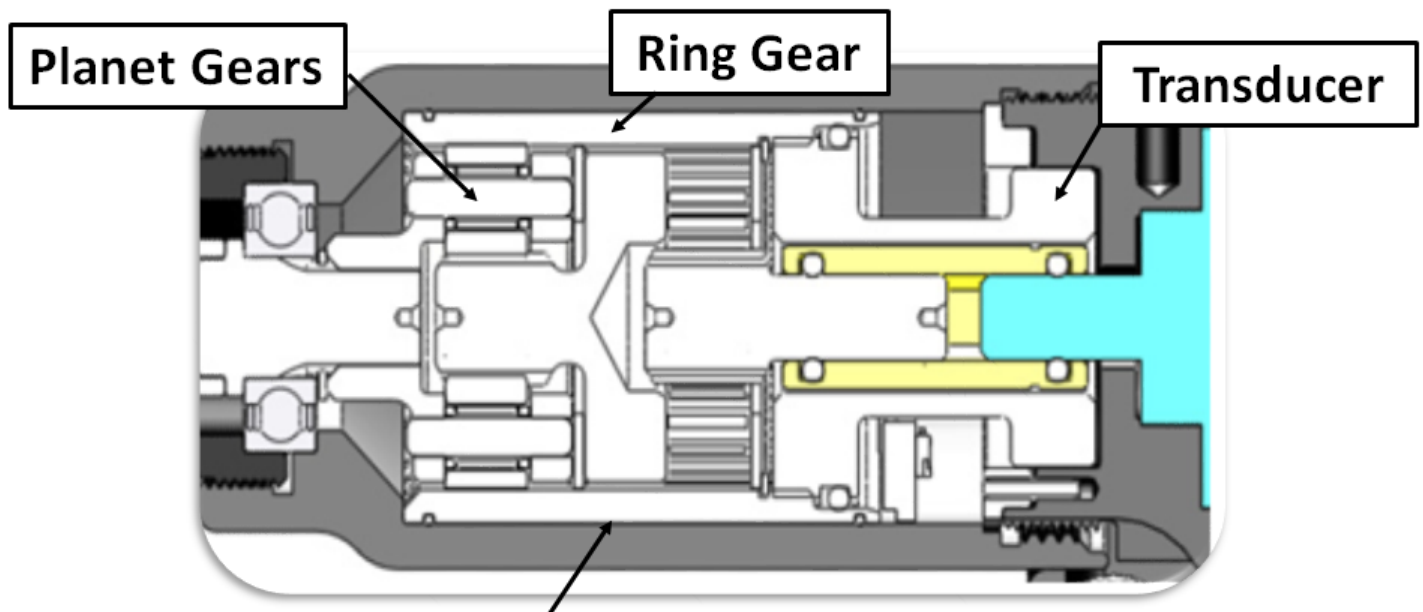

The ring gear is free to float held in place between the transducer and the planet gears

Where to fixrture AcraDyne Right Angle Tools

1000-Series



2000-Series

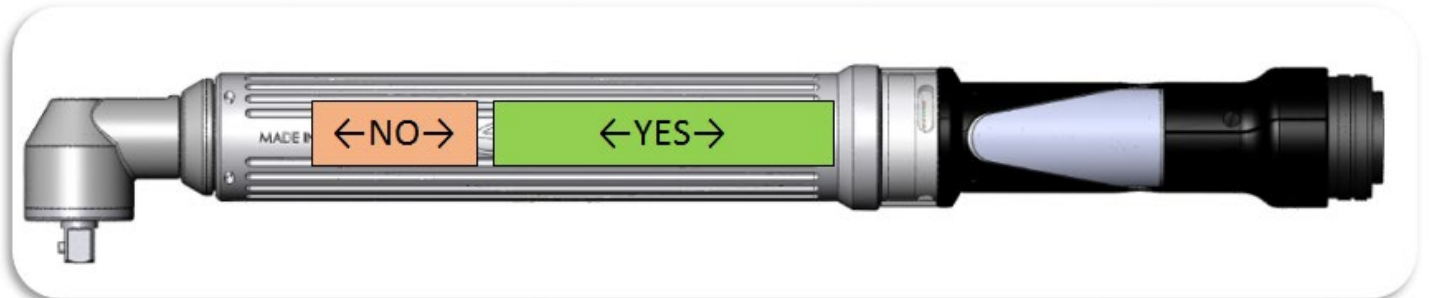

3000-Series without Black Gearbox

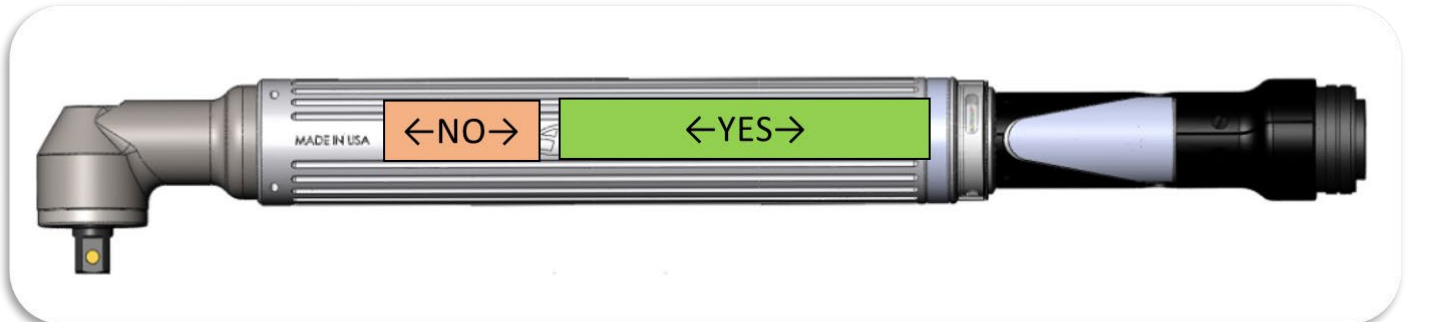

3000-Series **with** Black Gearbox

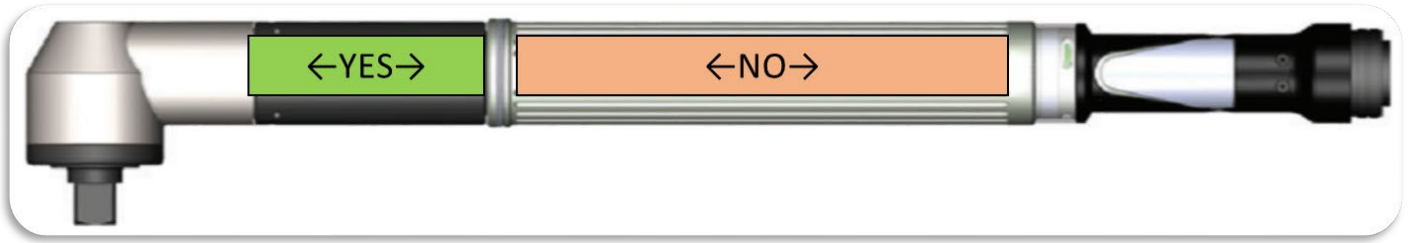

5000-Series

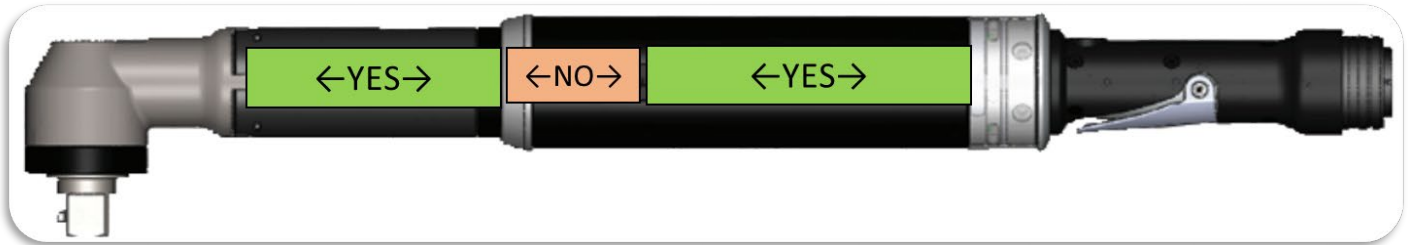

HT Angle Tool or any tool with additional gearbox

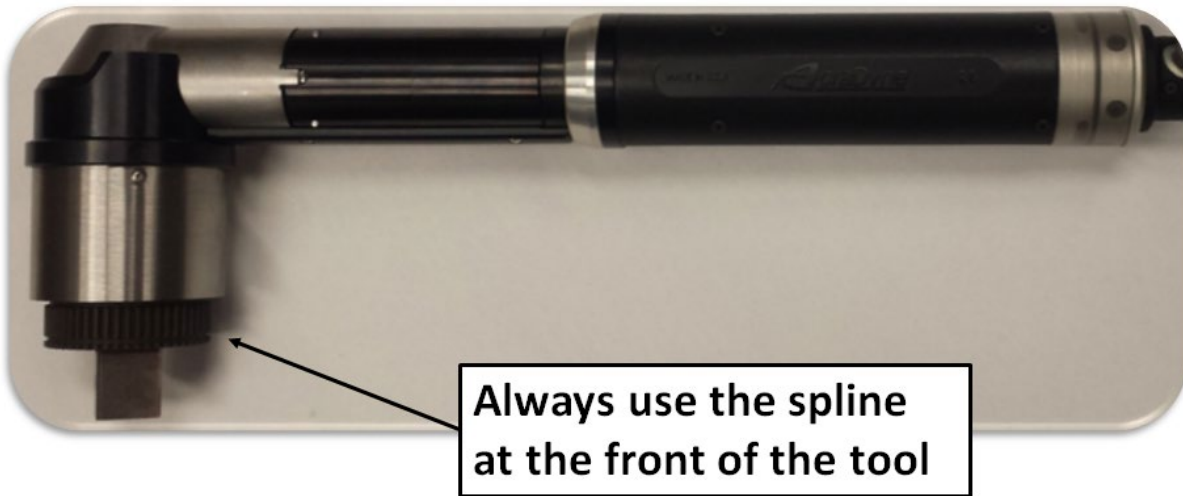

Pistol and Straight Tools

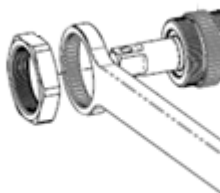
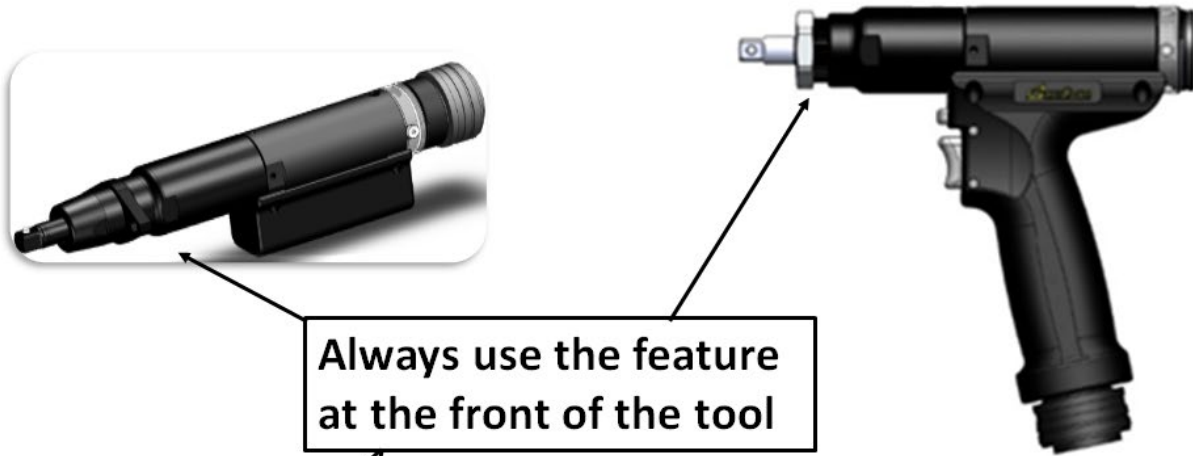

Reaction bars and mounting flanges are interchangeable

3000 and 5000 Series tools with this style gearbox use 23792 fixture nut on front hex.

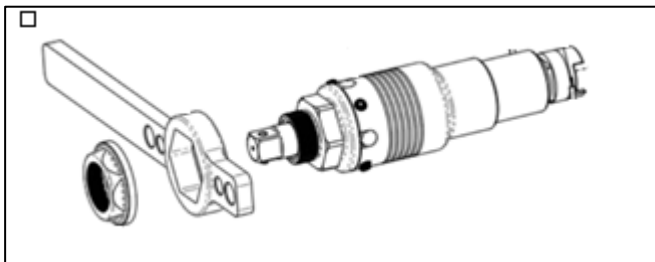

11.2 HT Series tools 6000 through 8000 series

All AcraDyne HT Series tools have the external ring gear gaged and work on the principle of reading the external reaction. HT tools must all be used with a reaction device that is tied to the external spline.



11.3 suspension bails

When using a balancer tools are hung from a suspension bail attached to the tool at the mounting holes provided.

UAT 50 Series straight pulse tool



ULT 90 Series pistol style pulse tool



UXR-T1820 pulse tool



2000/3000 Series AcraDyne tools can be suspended from a balancer by the rotating suspension bails sold by AIMCO.



AcraDyne 3000 Series angle tool

12 Safety Information

CAUTION – DO NOT USE THE ACRADYNE® NUTRUNNING SYSTEM WITHOUT FULLY READING SAFETY INFORMATION AND HAVING A COMPLETE UNDERSTANDING OF THE CORRECT USAGE OF A HIGH TORQUE DELIVERING TOOL AND ANY ASSOCIATED REACTION BARS/ACCESSORIES.

SAVE THESE INSTRUCTIONS

1) WORK AREA

- a) Keep work area clean and well lit. Cluttered and dark areas invite accidents.
- b) Do not operate power tools in explosive atmospheres, such as the presence of flammable liquids, gases or dust. Power tools create sparks which may ignite the dust or fumes.
- c) Keep children and bystanders away while operating a power tool. Distractions can cause you to lose control.

2) ELECTRICAL SAFETY

- a) Power tool plugs must match the outlet. Never modify the plug in any way. Do not use any adapter plugs with earthed (grounded) power tools. Unmodified plugs and matching outlets will reduce risk of electric shock.
- b) Avoid body contact with earthed or grounded surfaces such as pipes, radiators, ranges and refrigerators. There is an increased risk of electric shock if your body is earthed or grounded.
- c) Do not expose power tools to rain or wet conditions. Water entering a power tool will increase the risk of electric shock.
- d) Do not abuse the cord. Never use the cord for carrying, pulling or unplugging the power tool. Keep cord away from heat, oil, sharp edges or moving parts. Damaged or entangled cords increase the risk of electric shock.
- e) This tool is intended for indoor use only.



3) PERSONAL SAFETY

INDICATES CAUTION IS REQUIRED. FAILURE TO EXERCISE CAUTION AND CORRECT OPERATING TECHNIQUE CAN RESULT IN SERIOUS PERSONAL INJURY, LOSS OF LIMB OR DEATH.

- a) Stay alert, watch what you are doing and use common sense when operating a power tool. Do not use a power tool while you are tired or under the influence of drugs, alcohol or medication. A moment of inattention while operating power tools may result in serious personal injury.
- b) Use safety equipment. Always wear eye protection. Safety equipment such as dust mask, non-skid safety shoes, hard hat, or hearing protection used for appropriate conditions will reduce personal injuries. If the maximum duty cycle of the attached tool is exceeded or the tool temperature exceeds 50° C., then the operator should wear protective hand wear (gloves).
- c) Avoid accidental starting. Ensure the switch is in the off-position before plugging in. Carrying power tools with your finger on the switch or plugging in power tools that have the switch on invites accidents.
- d) Remove any adjusting key or wrench before turning the power tool on. A wrench or a key left attached to a rotating part of the power tool may result in personal injury.
- e) Do not overreach. Keep proper footing and balance at all times. This enables better control of the power tool in unexpected situations.
- f) Dress properly. Do not wear loose clothing or jewelry. Keep your hair, clothing and gloves away from moving parts. Loose clothes, jewelry or long hair can be caught in moving parts.
- g) If devices are provided for the connection of dust extraction and collection facilities, ensure these are connected and properly used. Use of these devices can reduce dust-related hazards.

4) POWER TOOL USE AND CARE

- a) Do not force the power tool. Use the correct power tool for your application. The correct power tool will do the job better and safer at the rate for which it was designed.
- b) Do not use the power tool if the switch does not turn it on and off. Any power tool that cannot be controlled with the switch is dangerous and must be repaired.
- c) This product is designed to be used in combination with the AcraDyne iEC DC tool controller for intermittent hand-held or fixture assembly processes.

5) SECURE TOOL

- a) Make sure to follow instructions and properly secure the tool or damage to the tool, part or operator could possibly result.



CORPORATE HEADQUARTERS

10000 SE Pine Street
Portland, Oregon 97216
Phone: (503) 254-6600
Toll Free: 1-800-852-1368

AIMCO CORPORATION DE MEXICO SA DE CV

Ave. Cristobal Colon 14529
Chihuahua, Chihuahua. 31125
Mexico
Phone: (01-614) 380-1010
Fax: (01-614) 380-1019

AIMCO CHINA

Room 607, No. 3998 Hongxin Rd
Minhang District, Shanghai
China
Phone: 0086-21-34319246
Fax: 0086-21-34319245

AIMCO SOUTH AMERICA

Calle Congreve No 800. Escobar
El Aromo. L207
Provincia de Buenos Aires
Argentina
CP: 1625
Phone: +54 9 11 3341 0543

AIMCO SOUTH KOREA

B-1213, 167, Songpa-Daero
Songpa-Gu, Seoul 05800
South Korea
Phone: 0082-2-2054-8930
Cell: 0082-10-9804-8905

LIT-MAN905 Rev. 01-19-15
Printed in USA ©2015 AIMCO