

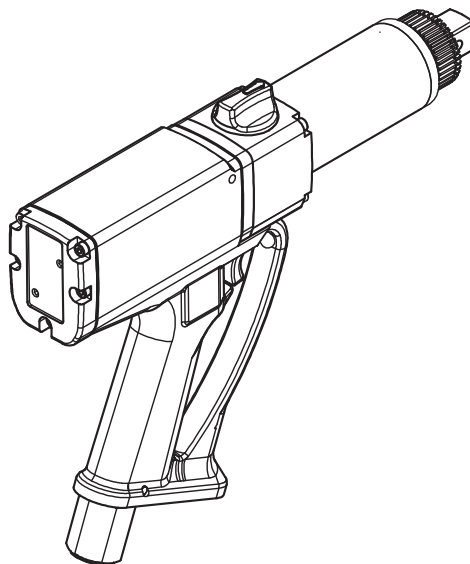

**DynaTorque**  
**PT 52 Series – Stall Tools**  
**52/600 & 52/1000**  
**Owner's Manual**



PO Box 16460, Portland OR 97292-0460 • 800-852-1368 • Fax 800-582-9015

[www.aimco-global.com](http://www.aimco-global.com)



## CONTENTS

	<u>PAGE</u>
<b>Safety</b>	<b>2</b>
<b>Introduction</b>	<b>3</b>
<b>Features and Functions</b>	<b>4</b>
<b>Set up Instructions</b>	<b>4</b>
<b>Operating Instructions</b>	<b>10</b>
<b>Maintenance</b>	<b>12</b>
<b>Specification</b>	<b>14</b>
<b>Declaration of Conformity</b>	<b>15</b>
<b>Trouble shooting</b>	<b>16</b>
<b>Glossary of terms</b>	<b>16</b>

### MODEL NUMBERS COVERED BY MANUAL:- \_\_\_\_\_

PART CODE	DIRECTION	MODEL	MAXIMUM TORQUE	TOOL TYPE
18039.F06	Forward (Clockwise) only.	PT52/600 Stall Tool	600 N.m	Tool stalls against external regulator setting.
18039.B06	Bi-directional.			
18040.F06	Forward (Clockwise) only.	PT52/1000 Stall Tool	1000 N.m	Tool stalls against external regulator setting.
18040.B06	Bi-directional.			
18041.F06	Forward (Clockwise) only.	PT52/600 Stall Tool with Torque Regulator	600 N.m	Tool stalls against internal regulator setting.
18041.B06	Bi-directional.			
18042.F06	Forward (Clockwise) only.	PT52/1000 Stall Tool with Torque Regulator	1000 N.m	Tool stalls against internal regulator setting.
18042.B06	Bi-directional.			

The '06' suffix in the part number indicates a  $\frac{3}{4}$ " A/F drive square size.

## SAFETY

**IMPORTANT: DO NOT OPERATE THE TOOL BEFORE READING THESE INSTRUCTIONS. FAILURE TO DO SO MAY RESULT IN PERSONAL INJURY OR DAMAGE TO THE TOOL.**

This tool is intended for use with threaded fasteners. Any other use is not recommended.

The use of ear protectors is recommended.

Do not use tool in potentially explosive atmosphere as these tools contain grease, which may cause an explosion hazard in the presence of pure oxygen. These tools also contain aluminium alloy components which may cause a hazard in certain explosive environments.

Be aware of unexpected tool movement due to reaction forces as this may cause injuries. Failure of the drive square may also cause unexpected tool movement.

Isolate the tool from all energy sources before changing or adjusting the drive square or socket.



There is a risk of crushing between the reaction bar and work piece.

Keep hands away from reaction bar.

Keep hands away from tool output.

Keep loose clothing, hair, etc. from being caught in any rotating part of the tool.

These tools require a reaction bar. See section on Torque Reaction.

Ensure all hoses are correctly fitted before switching on the mains air supply. This avoids the risk of injury by whipping air hoses.

Use only sockets and adaptors which are in good condition and are intended for use with power tools.

Pneutorque® Wrenches are non impacting, torque controlled bolt tightening tools and must always be operated with the following:-

- Clean dry air supply with a minimum flow of 19 litres/sec (40 CFM).
- Air Regulator and optional Lubricator Unit 1/2" Bore (12 mm).
- Impact or high quality sockets.
- Reaction Arm.

## INTRODUCTION

The Pneutorque® 52mm series are air driven power tools designed for applying torque to threaded fasteners. There are models to cover torque capacities of 600 N.m and 1000 N.m. These models are available in 2 types:

### Stall Tool

These tools use the air pressure set on an external pressure regulator to determine the stall torque.

### Stall Tool with Internal Regulator

These tools use an in-built pressure regulator to control the stall torque. This allows the tool to be set without the need for a separate external pressure regulator.

### **PARTS INCLUDED:-** \_\_\_\_\_

PART CODE	DESCRIPTION	QUANTITY
180***.06	Pneutorque®	1
18646	Cranked Reaction Arm	1
18747	Lifting Bracket	1
26588	Reaction Plate Retaining Circlip	1
34281	Operators Handbook	1
J2364	Regulator Adjusting Tool (supplied with regulator tools only)	1

### **ACCESSORIES:-** \_\_\_\_\_

PART CODE	DESCRIPTION
18594.006	6" Nose Extension
18594.009	9" Nose Extension
18594.012	12" Nose Extension
18544	¾" Drive Square
18545	1" Drive Square
18576	Single-sided Reaction Plate
18590	Double-sided Reaction Plate
* 18558	Reaction Plate
* 18298	Reaction Arm
18591	Silencer
16036	Lubro Control Unit

\* Requires both parts to form a suitable reaction device.

## FEATURES AND FUNCTIONS

### REPLACEABLE DRIVE SQUARE

All tools are fitted with a  $\frac{3}{4}$ " (19mm) drive square that can easily be replaced. A 1" drive square (Part Code 18545) is also available.

### TRIGGER

The trigger controls the flow of air. The more the trigger is pressed the more air flows into the tool. This allows for slow positioning of socket and reaction plate. Once positioning is complete, the trigger must be fully depressed for correct torque application.

### CLOCKWISE / COUNTER-CLOCKWISE SELECTOR

Tools fitted with this option can be used for releasing bolts as well as tightening. The gearing inside the housing is biased towards counter-clockwise drive to give a higher torque for releasing the fastener.

### LIFTING BRACKET

The metal bracket can be used to suspend the tool from a balancer.

## SET UP INSTRUCTIONS



**WARNING: TO AVOID HAZARD FROM WHIPPING AIR HOSES MAKE ALL CONNECTIONS TO THE TOOL BEFORE TURNING ON THE AIR SUPPLY.**

Make sure all air hoses are clean and free from dirt.

1. Connect the tool air inlet hose (C) to the outlet side of the pressure regulator unit (B), observing air flow direction arrows. Use a  $\frac{1}{2}$ " bore hose with a maximum length of 3m.

**TIP.** To connect the air inlet hose to a  $\frac{1}{2}$ " bore hose use a  $\frac{1}{2}$ " BSP Male/Male connector. A pair of spanners will be required to perform this task (22mm (7/8") A/F and 24mm (15/16") A/F open-ended spanners)

2. Connect the inlet side of the pressure regulator unit (B) to the mains air supply (A) using a minimum hose size of  $\frac{1}{2}$ " bore (12mm). Avoid using  $\frac{1}{2}$ " bore hoses of longer than 5 meters from the supply to the pressure regulator unit as this will reduce the performance of the tool.

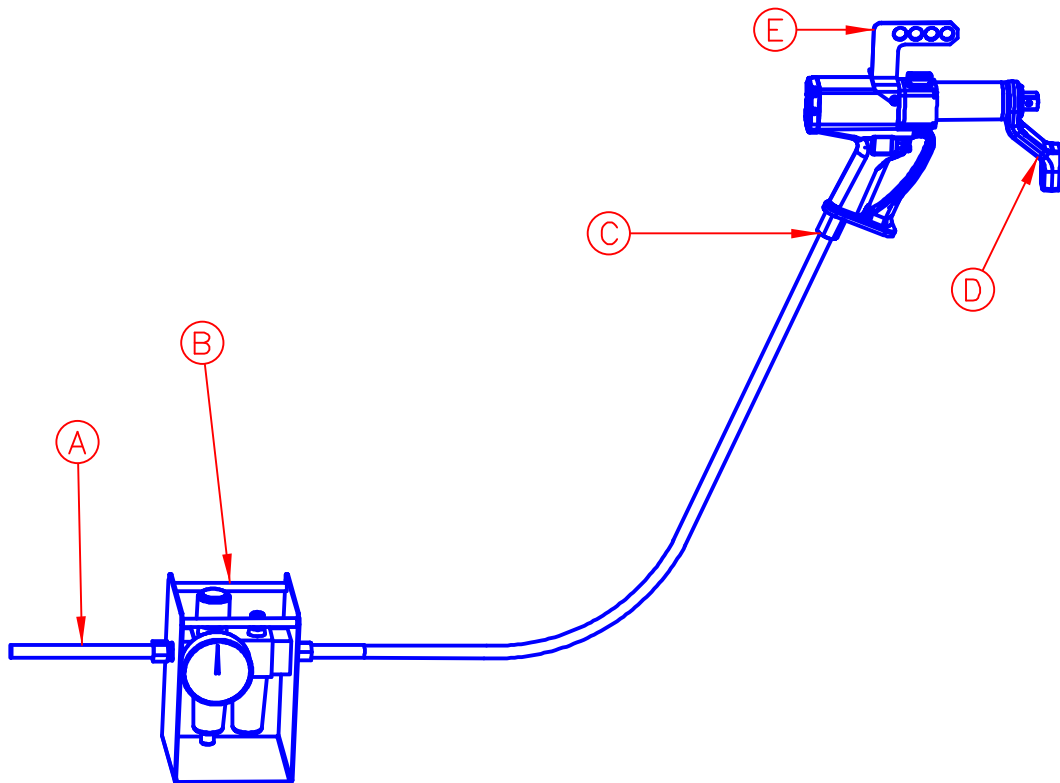

**Figure 1**

3. If running the tool with oil, check the oil level in the lubricator and fill to the correct level if required. (see MAINTENANCE section)

TIP. These tools have been designed to run with a clean, dry, unlubricated air supply if required, but this is not essential. It is best to run a tool with unlubricated air from new as this avoids early oil deposits solidifying and clogging the vane slots.

4. Fit reaction plate (D) over drive square to engage reaction splines. Fit circlip (#26588) supplied.
5. Fit lifting bracket (E) into two holes in the side of the handle.

**NOTE: LIFTING BRACKET SECURING SCREWS MUST BE TORQUED UP TO 5 N.M.**

TIP. The hanger should be used only in conjunction with a suitable balancer. If the tool is to be used without a balancer or hanging device there is no need to fit the hanger to the tool.

## TORQUE REACTION

When the Pneutorque® is in operation the reaction arm rotates in the opposite direction to the output drive square and must be allowed to rest squarely against a solid object or surface adjacent to the bolt to be tightened. (See figure 2).

**WARNING: ALWAYS KEEP HANDS CLEAR OF THE REACTION ARM WHEN THE TOOL IS IN USE OR SERIOUS INJURY MAY RESULT.**

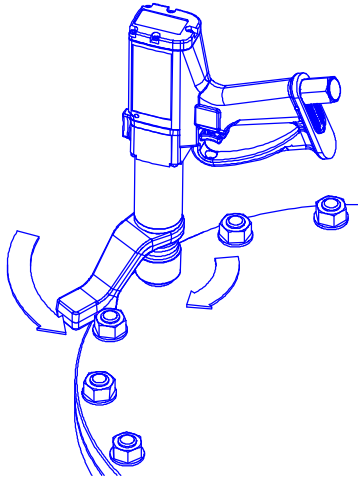

Figure 2a (Clockwise)

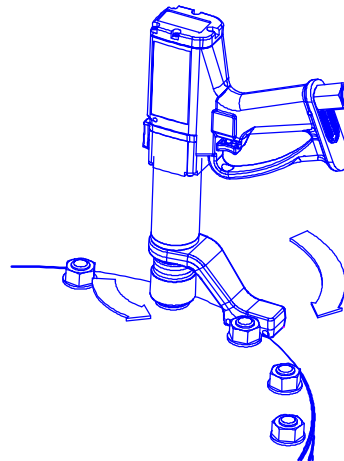

Figure 2b (Counter-clockwise)



**WARNING: CARE MUST BE TAKEN TO ENSURE THAT THE REACTION ARM IS ONLY USED WITHIN THE LIMITATIONS SHOWN IN FIGURE 3.**

For special applications or where extra deep sockets must be used the standard arm may be extended but only within the limitations shown on Figure 3.

Alternative reaction devices are available.



**WARNING: FAILURE TO OBSERVE THE LIMITATIONS SHOWN IN FIGURE 3 WHEN MODIFYING STANDARD REACTION ARMS MAY RESULT IN PREMATURE WEAR OR DAMAGE TO THE TOOL.**

Standard drive square extensions **MUST NOT** be used as these will cause serious damage to the tool output drive. A range of nose extensions is available for applications where access is restricted. These are designed to support the final drive correctly.

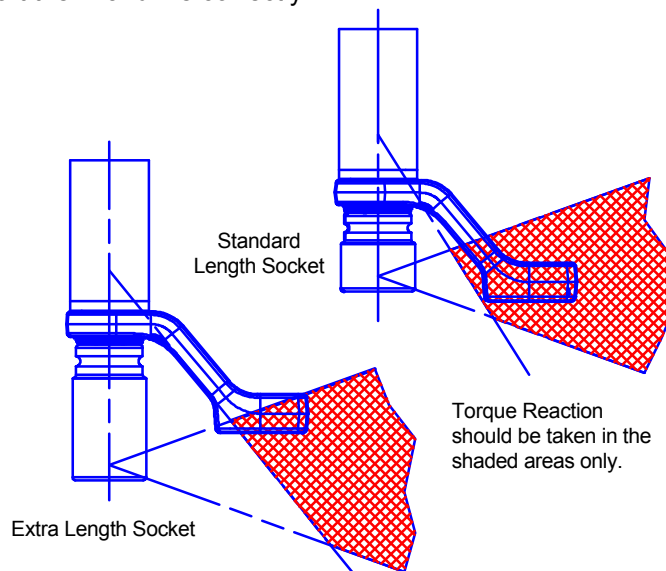
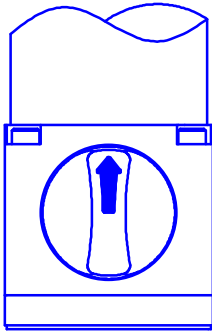

Figure 3



## SETTING CLOCKWISE/COUNTER-CLOCKWISE OPERATION \_\_\_\_\_



**Clockwise**  
(Arrow towards drive square)

**Figure 4a**

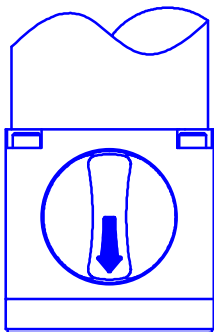

**Counter-clockwise**  
(Arrow away from drive square)

**Figure 4b**

**TIP:** To help set the clockwise / counter-clockwise operation run the tool in *neutral* position before re-engaging.

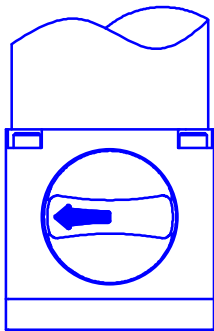

**Neutral position**

**Figure 4c**



**WARNING:** FAILURE TO FULLY ENGAGE THE CLOCKWISE/COUNTER-CLOCKWISE OPERATION SELECTOR WILL RESULT IN DAMAGE TO THIS PART OF THE GEARBOX.

## SETTING TORQUE FOR BOLT TIGHTENING

---

### STALL TOOL – MODEL 18039 AND 18040

---

These tools use the air pressure set on an external pressure regulator unit to determine the stall torque. They are supplied with an Air Pressure Graph which relates torque output to air pressure. Set the torque output as follows:-

1. Ensure the Clockwise/Counter-clockwise Selector (if fitted) is correctly set.
2. Establish the air pressure required using the Air Pressure Graph.
3. With the tool running, adjust the pressure regulator until the correct figure is shown on the gauge.

**IMPORTANT: THE WRENCH MUST BE FREE RUNNING WHILE ADJUSTING THE AIR PRESSURE TO GIVE THE CORRECT SETTING.**

### STALL TOOL FITTED WITH TORQUE REGULATOR – MODEL 18041 AND 18042

---

The tool can be set in one of two ways.

- A. The tool can be set against the Air Pressure Graph in the same way as the stall tool without the internal regulator as long as the regulator valve is fully open. (This is factory set fully open). For this method follow the same setup as for Models 18039 and 18040.
- B. To set the torque regulator a suitable calibration device will be required. (see Glossary of Terms) Set the tool by the following procedure.

1. Ensure the Clockwise/Counter-clockwise Selector (if fitted) is correctly set.
2. If the tool is connected up to the mains air supply, switch off the supply and press the trigger to release any air trapped between the pressure regulator and the tool. Remove the air hose from the tool.
3. Fit the adjusting tool J2364 into the air inlet tube until the box spanner engages onto the locknut (A). Loosen the locknut (C) by 90 degrees.
4. Engage the screwdriver (D) into the slot in the end of the valve body (B). Rotate screwdriver (D) to change torque setting.
5. Tighten locknut (C) and remove adjusting tool.
6. Re-attach the tool to the air supply and check the stall torque against a calibration device. This process may take several adjustments to achieve the final setting.
7. The tool is now ready for use.

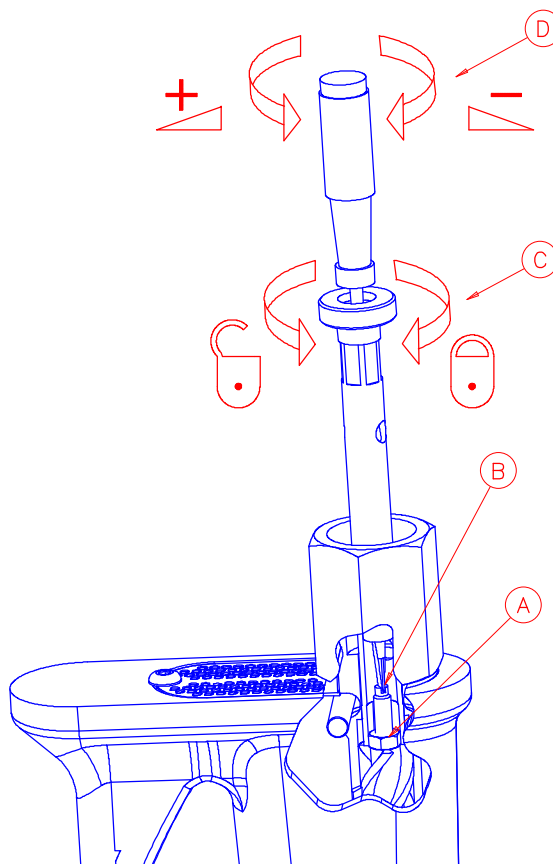

Figure 5

**NOTE: THE TORQUE REGULATOR WILL NOT GIVE FULL CONTROL OVER THE ENTIRE RANGE OF THE TOOL. THE RANGE OF THE REGULATOR IS FROM FULL TORQUE TO APPROXIMATELY 50% OF FULL TORQUE VALUE.**

**TIP:** If a lower torque level is required it may be achieved by reducing the mains air pressure to the tool.

**NOTE: REPEATABILITY OF THE TOOL MAYBE AFFECTED BY THE USE OF THIS REGULATOR.**

**IMPORTANT: IF RUNNING THE TOOL WITH LUBRICATION, CHECK THAT THE LUBRO CONTROL UNIT IS SUPPLYING APPROXIMATELY SIX DROPS OF OIL PER MINUTE WHILE THE TOOL IS FREE RUNNING.**

**IF THE TOOL IS USED WITH AN INTERNAL TORQUE REGULATOR THE TOOL MUST BE CALIBRATED TO A PRE-SET TORQUE VALUE ON A SUITABLE CALIBRATION FIXTURE – IF IN DOUBT CONTACT YOUR DISTRIBUTOR.**

**SETTING TORQUE FOR RELEASING BOLT** \_\_\_\_\_

**NOTE: THIS PROCEDURE IS ONLY APPLICABLE TO BI-DIRECTIONAL TOOLS.**

The tools are designed to give a slightly higher torque in counter-clockwise rotation. This may allow some tight bolts to be released without the need to set a higher air pressure.

1. Ensure the Clockwise/Counter-clockwise Selector is correctly set.
2. Pull trigger to loosen fastener.

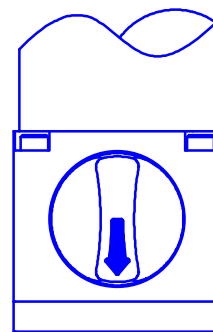

**Figure 6**

**TIP:** Increase air pressure slightly if fastener will not release.



**WARNING: EXCEEDING THE MAXIMUM AIR PRESSURE WILL CAUSE OVERLOADING AND MAY LEAD TO SERIOUS DAMAGE.**



**WARNING: CHANGING THE MAINS AIR PRESSURE AFTER SETTING THE PRESSURE REGULATOR WILL CHANGE THE STALL TORQUE VALUE.**

## OPERATING INSTRUCTIONS



**WARNING: KEEP HANDS CLEAR OF THE REACTION ARM.**



**WARNING: WHEN USING THIS TOOL IT MUST BE SUPPORTED AT ALL TIMES IN ORDER TO PREVENT UNEXPECTED RELEASE IN THE EVENT OF FASTENER OR COMPONENT FAILURE.**

### A. TIGHTENING

---

1. Fit Pneutorque® with the correct size impact or high quality socket to suit fastener.
2. Ensure the Clockwise/Counter-clockwise Selector is correctly set (if fitted).
3. Rotate the Handle into a convenient position relative to the reaction arm. Fit the tool onto the fastener to be tightened with the reaction arm adjacent to the reaction point. See Figure 7.
4. Adopt a suitable posture to counteract normal or unexpected movement of the tool due to reaction forces.
5. Squeeze the Trigger partially to bring the Reaction Arm into contact with the reaction point.
6. Fully depress trigger and keep fully depressed until tool stalls then release trigger.  
If the trigger is not fully depressed full torque will not be applied to the fastener.
7. Remove tool from fastener.

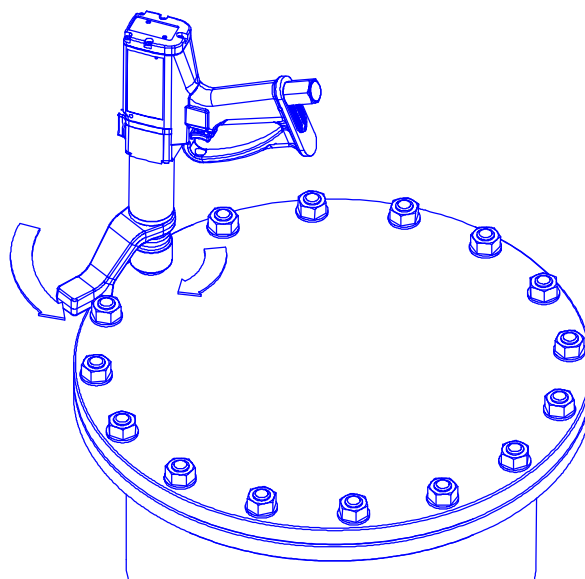

**Figure 7**

## B. RELEASING

---

### NOTE: ONLY FOR BI-DIRECTIONAL TOOLS

1. Fit the Pneutorque® with the correct size impact or high quality socket to suit the fastener to be released.
2. Ensure the clockwise/counter-clockwise selector is correctly set.
3. Rotate the handle into a convenient position relative to the reaction arm. Fit the tool onto the fastener to be released with the reaction arm adjacent to the reaction point. See Figure 8.
4. Adopt a suitable posture to counteract normal or unexpected movement of the tool due to reaction forces.
5. Squeeze the trigger partially to bring the reaction arm into contact with the reaction point.
6. Fully depress trigger and keep fully depressed until bolt releases.

TIP: If unable to release the bolt increase the air pressure to the tool. Do not use excessive air pressure.



**WARNING: EXCEEDING THE MAXIMUM AIR PRESSURE WILL CAUSE OVERLOADING AND MAY LEAD TO SERIOUS DAMAGE.**



**WARNING: CHANGING THE MAINS AIR PRESSURE AFTER SETTING THE PRESSURE REGULATOR WILL CHANGE THE STALL TORQUE VALUE.**

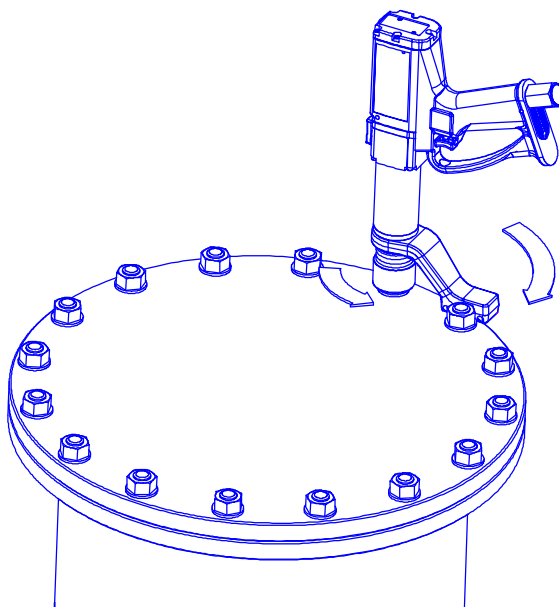

Figure 8

## MAINTENANCE

To maintain optimum performance and safety, regular maintenance needs to be carried out. The only user maintenance required on these tools is the replacement of drive squares and the silencer. Any other maintenance or repairs should be carried out by Norbar or a Norbar approved agent and should form part of a service. Service intervals will depend on the type of usage of the tools and the environment in which they are being used.

### AIR LUBRICATION:-

Add Shell Tellus 15 or equivalent good quality hydraulic oil to the Lubro unit.

NOTE: *The tools may be run without air lubrication to avoid the possibility of oil mist.*

### GEARBOX:-

Under normal operating conditions it is not necessary to re-grease the gearbox. The gearbox contains Lubcon Turmogrease Li 802 EP or equivalent good quality grease.

### SILENCER:-

The silencer (#18591) must be changed every 12 months. This may be more frequent for high tool usage or dirty environments.

**TIP:** Change silencer with tool upside down, as shown, to ensure internal parts (spring & valve) are kept in place.

1. Remove M4 screw (A) (#25381.10) using a 2.5mm hexagon key.
2. Remove pin (B) (#26284) using a pin punch.
3. Pull out air inlet tube (D) with base plate & silencer.
4. Remove silencer (E) from air inlet tube.
5. Fit new silencer (#18591) over air inlet tube.
6. Fit air inlet tube assembly (C, D & E) into handle against spring resistance.
7. Fit pin (B) with a hammer.
8. Fit screw (A) hand tight. Do not over tighten this screw as it is likely to break the base plate moulding.(0.5N.m MAX)

**TIP:** When refitting air inlet tube assembly into handle care should be taken to ensure correct alignment between air inlet tube & spring. It may be easier to fit the spring into air inlet tube first and secure with a small amount of grease.

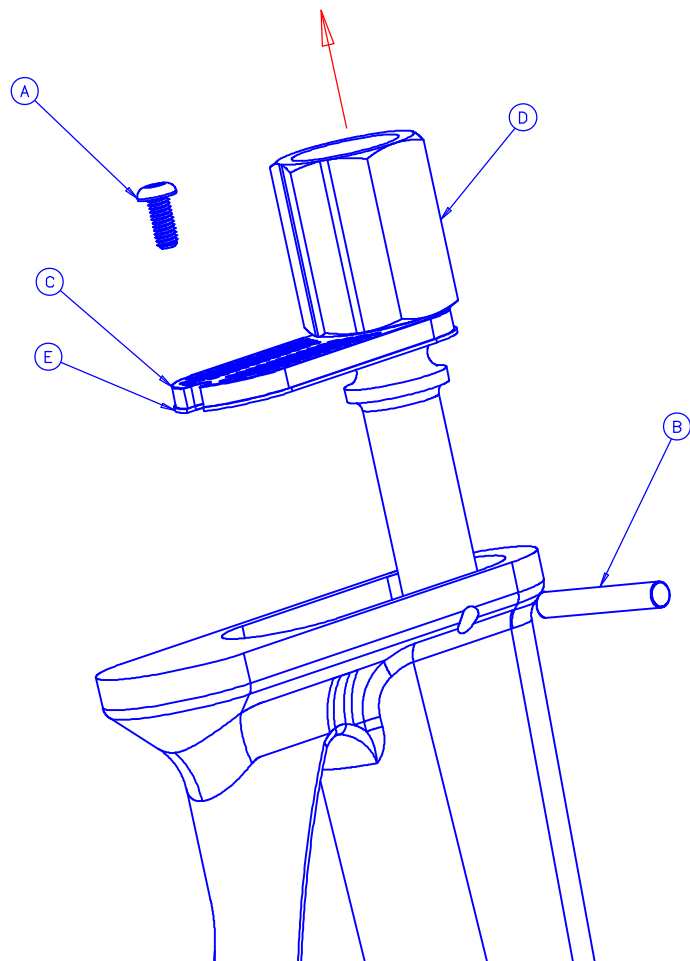
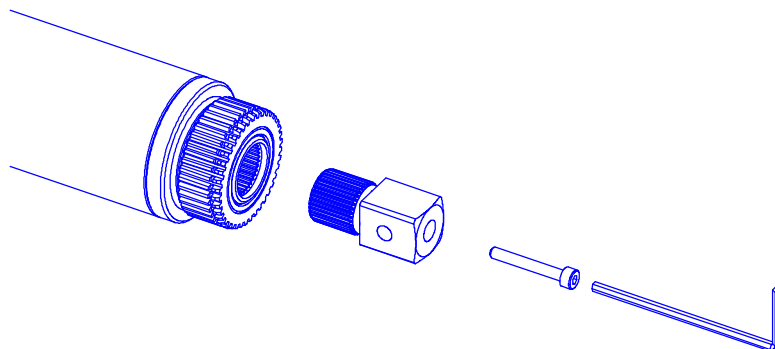

Figure 9

**DRIVE SQUARE:-** \_\_\_\_\_

To avoid internal damage (especially due to torque overload), the output drive square has been designed to shear first. This saves major internal damage and allows easy square removal.



**Figure 10**

The drive square can be replaced with either a  $\frac{3}{4}$ " drive square (#18544), or a 1" drive square (#18545). A new retaining screw (#25351.30) is supplied with the square.

To replace drive square:

1. Use 3mm hexagon key to remove screw.
2. Remove drive square.
3. Fit new drive square.
4. Fit new screw and tighten to 4 N.m - 5 N.m.

**TIP:** If the square has sheared it may be necessary to use pliers to remove the broken parts.

**CLEANING:-** \_\_\_\_\_

Keep the tool in a clean condition to aid safety. Do not use abrasives or solvent based cleaners.

## SPECIFICATIONS

MODEL	RANGE		MAXIMUM OVERLOAD	TOOL SPEED (FREE RUNNING AT MAX. AIR PRESSURE)
	MIN	MAX		
18039 & 18041	120 N.m	600 N.m	660 N.m	200 r/min
18040 & 18042	200 N.m	1000 N.m	1100 N.m	125 r/min

Repeatability:	± 5%
Air Supply:	Maximum pressure – 6.3 bar (For maximum torque capacity).
Recommended Lubrication:	Shell Tellus S2 V 15 for the Lubro Control Unit.
Temperature Range:	0°C to +50°C (operating). -20°C to +60°C (storage).
Maximum Operating Humidity:	85% Relative Humidity @30°C.
Case Materials / Finish:	Handle: Aluminium casting with epoxy powder finish. Direction Gearbox: Aluminium with epoxy powder finish. Annulus: Alloy steel with nickel plate finish. Reaction Plate: Alloy steel with epoxy powder finish.

TYPE	MODELS	WEIGHT	DIMENSIONS
Forward (Clockwise) only	180XX.F06	3.8 kg (8.8lb)	345mm x 55mm wide x 255mm
Bi-directional	180XX.B06	4.0 kg (9.3lb)	385mm x 55mm wide x 255mm

Maximum Vibration at Handle:	< 2.5m/s <sup>2</sup> Tested in accordance with ISO 8662-7 Hand Held portable tools – Measurement of vibrations at the handle.
Sound Pressure Level:	83 dBA measured at 1m equivalent continuous A weighted sound. Tested to BS ISO 3744: 1994 Acoustics – Determination of sound power levels of noise sources using sound pressure – Engineering method in an essentially free field over a reflecting plane. Test conducted in free running condition with a supply pressure of 6.3 bar.
Environment:	Indoor use within a light industrial environment.
Machinery Directive:	In conformance with: BSEN 792-6:2000 Hand-held non-electric power tools. Safety requirements. Assembly power tools for threaded fasteners.

*Due to continuous improvement all specifications are subject to change without prior notice.*



# Declaration of Conformity

**Manufactured by**     **Norbar Torque Tools Ltd.,**  
                                 **Beaumont Road, Banbury, Oxon, OX16 1XJ**

## **The Directives covered by this Declaration**

Safety of Machinery Directive, 98/37/EEC

## **The Equipment Covered by this Declaration**

**Equipment:**        52mm Stall Tool.

**Model No.(s):**    18039.F06, 18039.B06,  
                                 18040.F06, 18040.B06,  
                                 18041.F06, 18041.B06,  
                                 18042.F06, & 18042.B06.

## **The Basis on which Conformity is being Declared**

The equipment identified above is in compliance with the protection requirements of the above directives, and the following standards have been applied:-

EN 792-6:2000        Hand-held non-electric power tools – Safety requirements  
                                 Pt 6: Assembly power tools for threaded fasteners

The technical documentation required to demonstrate that the products meet the requirements of the above Directives has been compiled and is available for inspection by the relevant enforcement authorities. The CE mark was first applied in: 2002.

**Signed:**            *T. M. Lester*                            **Full Name:**    Trevor Lester

**Date:**                17<sup>th</sup> June 2005                            **Authority:**     Compliance Engineer

## TROUBLE SHOOTING

The following is only a guide, for more complex faults please contact your local Norbar distributor or Norbar directly.

PROBLEM	LIKELY SOLUTIONS
Tool output does not rotate when trigger pulled.	Check air supply is functioning & connected. Check air pressure setting (at least 1 bar). Check correct setting of direction knob. Output drive square sheared, needs replacing. Gear train or air motor is damaged
Drive square sheared.	See maintenance section to replace.
Tool does not stall.	Tool has not achieved torque, increase air pressure. Fastener sheared or thread stripped. Gear train or air motor is damaged

## GLOSSARY OF TERMS

WORD OR TERM	MEANING
Air pressure graph	Graph supplied with Stall only tool to show air pressure setting against required torque.
Bi-directional	Tool capable of Clockwise & Counter-clockwise square rotation.
Lubro Control Unit	Unit to provide filtering and lubrication along with pressure regulation. Not supplied with tool.
Oil free air	Regulated air without oil lubrication.
Pneutorque®	Product name.
Reaction Arm	Device to counteract applied torque.
Calibration device	Torque calibration system comprising of suitable torque transducer and display capable of measuring peak torque along with a suitable run down fixture or test fastener. Alternatively use the torque transducer on the fastener being tightened.





---

**Corporate Headquarters**

10000 S.E. Pine St.  
Portland, OR 97216  
(800) 852-1368  
FAX (800) 582-9015  
[www.aimco-global.com](http://www.aimco-global.com)

**AIMCO Corporation De Mexico Sa De Cv**

Ave. Cristóbal Colon 14529  
Chihuahua, Chihuahua. 31125 Mexico  
+52-(614) 380-1010  
FAX +52 (614) 380-1019