



UX, UX-T Series Air Motor Repair Manual

**UX-450 ~ 612 and Larger UX & UX-T Air Motor,
Shut-off Section, and Angle Head**



Contents

	<u>Page Number</u>
1. Recommended Tools Needed for Repair	1
2. Air Motor Repair Fixtures	2-3
3. Disassembly and Reassembly of the Air Motor Section <ul style="list-style-type: none">• UX & UX-T	4
4. Exploded View of the Air Motor <ul style="list-style-type: none">• UX - Straight & Small “C” Series• UX-450 ~ 612	5 6
5. Disassembly and Reassembly of the Air Motor Section <ul style="list-style-type: none">• UX & UX-T Pistol Grip Handles and Larger “S” & “C” Models	7
6. Exploded View of the Air Motor <ul style="list-style-type: none">• UX Series• UX-T Series	8 9
7. Disassembly and Reassembly of the Shut-off Section <ul style="list-style-type: none">• UX-T	10
8. Exploded View of the Shut-off Valve Section <ul style="list-style-type: none">• UX-T700 ~ T1820	11
9. Repair and Adjustment of Angle Head Pulse Tool	12-13
10. Exploded View of the Angle Head Section <ul style="list-style-type: none">• UX-C Series	14
11. Preventative Maintenance	15

Recommended Tools Needed for Repair

1. One Set T-Handle Metric Allen Wrenches
2. Flat-Bladed Screwdrivers
3. 10 oz. Ball Peen Hammer
4. One Set Pin Punches
5. One Set O-Ring Picks
6. 6" Adjustable End Wrench
7. 12" Adjustable End Wrench
8. Medium Pair Channel Locks or Adjustable Jaw Pliers
9. Medium Honing Stone
10. 220 Grit Wet/Dry Sandpaper
11. Lap Plate
12. Loc-Tite #242
13. CFC Free Degreaser-Cleanser
14. Loc-Tite Accelerator
15. Arbor Press
16. O-Ring Installation Tools
17. Removal of Air Motor Connector (UX-450 through UX-612)
18. Auditor Series Monitor and Transducers with the UFT Joint Simulators
19. Needle Nose Pliers
20. Propane Torch
21. Teflon Seal Setter
22. Bearing Removal Jig
23. Bearing Setter

Air Motor Repair Fixtures

Fixtures for Disassembly & Reassembly of Casing Connector

Part Number	Tools Used With			
196-294-6-5	U-310SD			
192-035-4-5	U-350D	U-350SD		
177-036-6-5	UX-450 & ALPHA-60	UX-500 & ALPHA -T45	UX-612 & ALPHA -T50	ALPHA-50

Fixtures Set in O-Rings

Part Number	Tools Used With			
990-319-0-1	U-310SD	U-350D	U-350SD	
990-320-0-1	UX-500 UX-900	UX-602 UX-612	UX-620 UX-622	UX-800
990-971-0-1	UXR-1000 UXR-1820	UX-1300	UX-1400	UX-1620
990-972-0-1	UXR-2000	UXR-2000S	UXR-2400S	UXR-3000S

Fixtures for Removal of Ball Bearing for Cylinder Rear Plate

Part Number	Tools Used With			
982-033-0-2	U-310SD	U-350D	U-350SD	
982-100-0-2	U-410D	U-410S	U-410SD	
982-401-0-2	UX-500	UX-602	UX-612	
982-402-0-2	UX-620	UX-622	UX-700	
982-403-0-2	UX-800 UX-T800 UXR-T3000S	UX-900 UX-T900	UX-1000 UX-T1000	UX-T700 UXR-3000S
982-404-0-2	UX-1300	UX-T1300		
982-951-0-2	UX-1400 UXR-2000S UXR-T2000	UX-1620 UX-T1400	UXR-1820 UX-T1620	UXR-2000 UXR-T1820
982-104-0-2	UXR-2400S	UXR-T2400S		

Air Motor Repair Fixtures (cont.)

Fixtures for Removal of Ball Bearing for Cylinder Front Plate

Part Number	Tools Used With			
982-015-0-2	U-310SD	U-350D	U-350SD	
982-401-0-2	U-410	U-410D	U-410S	U-410SD
982-402-0-2	UX-500	UX-602	UX-612	
982-403-0-2	US-620	UX-622		
982-903-0-2	UX-700	UX-800	UX-900	UX-T700
	UX-T800	UX-T900		
982-951-0-2	UX-1000	UX-T1000		
982-104-0-2	UX-1300	UX-T1300		
982-205-0-2	UX-1400	UX-1620	UXR-1820	UX-T1400
	UX-T1620	UXR-T1820		
982-960-0-2	UXR-2000	UXR-2000S	UXR-T2000	
982-206-0-2	UXR-3000S	UXR-T3000S		

Fixtures for Pressing in of Ball Bearing for Cylinder Rear Plate

Part Number	Tools Used With			
982-033-0-1	U-310SD	U-350D	U-350SD	
982-100-0-1	U-410	U-410D	U-410S	U-410SD
982-401-0-1	UX-500	UX-602	UX-612	
982-402-0-1	UX-622	UX-620	UX-700	UX-T700
982-403-0-1	UX-800	UX-900	UX-1000	UX-T800
	UX-T900	UX-T1000		
982-404-0-1	UX-1300	UX-T1300		
982-103-0-1	UX-1400	UX-1620	UXR-1820	UXR-2000
	UXR-2000S	UX-T1400	UX-T1620	UXR-T1820
	UXR-T2000			
982-204-0-1	UXR-2400S	UXR-T2400S		
982-205-0-1	UXR-3000S	UXR-T3000S		
982-033-0-1	U-310SD	U-350D	U-350SD	

Fixtures for Pressing in of Ball Bearing for Cylinder Front Plate

Part Number	Tools Used With			
982-035-0-1	U-310SD	U-350D	U-350SD	
982-401-0-1	U-410	U-410D	U-410S	U-410SD
982-402-0-1	UX-500	UX-602	UX-612	
982-403-0-1	UX-622	UX-620		
982-102-0-1	UX-700	UX-T700		
982-950-0-1	UX-800	UX-900	UX-1300	UX-T800
	UX-T900	UX-T1300		
982-103-0-1	UX-1000	UX-T1000		
982-906-0-1	UX-1400	UX-1620	UXR-1820	UX-T1400
	UX-T1620	UXR-T1820		
982-205-0-1	UXR-2000	UXR-2000S	UXR-T2000	
982-206-0-1	UXR-2400S	UXR-3000S	UXR-T2400S	UXR-T3000S

Disassembly and Reassembly of the Air Motor Section

UX & UX-T

A. Straight Handles - UX-450 ~ UX-612 Pistol Grip and Smaller C Models

Disassembly

1. Remove Front Casing and Pulse Unit.
2. Remove Casing Connector if on the model you are working on.
3. Taking a hold of the Rotor and pull the whole Air Motor from the Handle.
4. Remove the Front Plate.
5. Remove the Front Plate Bearing from the Front Plate.
6. Remove the Cylinder.
7. Remove the Blades.
8. Press Rotor out of Bearing and away from Rear Plate.
9. Remove Rear Plate Bearing from the Rear Plate.

Inspection of Parts for Wear

1. Inspect Blades for splitting and side wear. Replace if worn.
2. Inspect Bearings for side play and knocking. Replace if worn.
3. Inspect Cylinder for waviness. Replace if worn.
4. Inspect Plates for grooving. Light marks can be lapped out using a figure eight motion with 220 grit sandpaper on a Lap Plate. If heavy grooving exists, replace.
5. Inspect Rotor for sharp edges in Blade Slots and pitting and grooving on Plate Surface. Light marks can be stoned with a medium oil stone. If deep markings exist, replace.
6. Inspect the O-rings in the Handle for splitting or chipping, replace if necessary.
7. Thoroughly clean all parts and blow dry.

Reassembly

1. Grease Rear Plate Bearing. Press into Rear Plate and over the rear of the Rotor at the same time.
2. There should be a small amount of drag between the Rear Plate and the Rotor. Some adjusting may be necessary.
3. Grease Front Plate Bearing and press into Front Plate.
4. Oil Blades and install into Rotor.
5. Slide Cylinder down over the Rotor lining up the ports on the Rear Plate with the ports on the Cylinder.
6. Set the Front Plate down over the Rotor and onto the Cylinder.
7. Holding the Rotor, slide the Air Motor into the Handle.
8. Thread the Casing Connector into the Handle. This should be torqued to 25 ft. lbs.
9. Reassemble Pulse Unit and Front Casing onto tool.

Exploded View of the Air Motor

UX - Straight & Small "C" Series

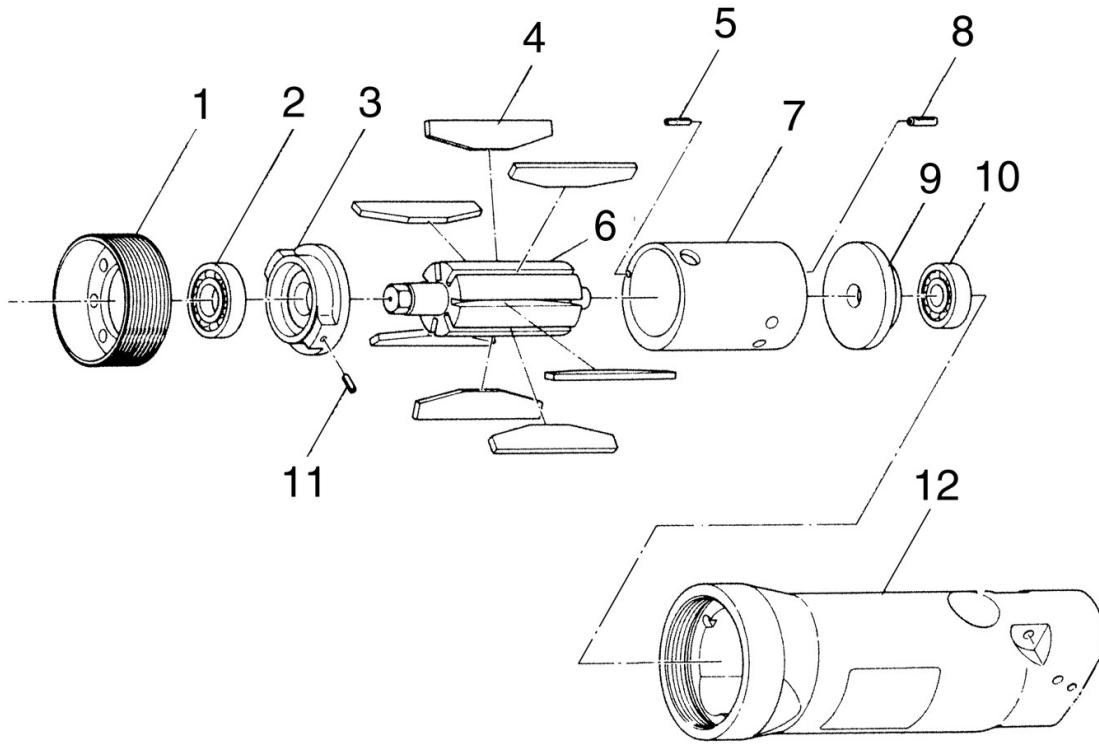

Part Number	Description	Part Number	Description
1	Casing Connector	9	Rear Plate
2	Front Plate Bearing	10	Rear Plate Bearing
3	Front Plate	11	O-Ring
4	Blades	12	Handle Casing
5	Rotor	13	Nylon Ball
6	Roll Pin	14	Roll Pin
7	Cylinder	15	Nylon Ball
8	Roll Pin		

Exploded View of the Air Motor (cont.)

UX-450 ~ 612

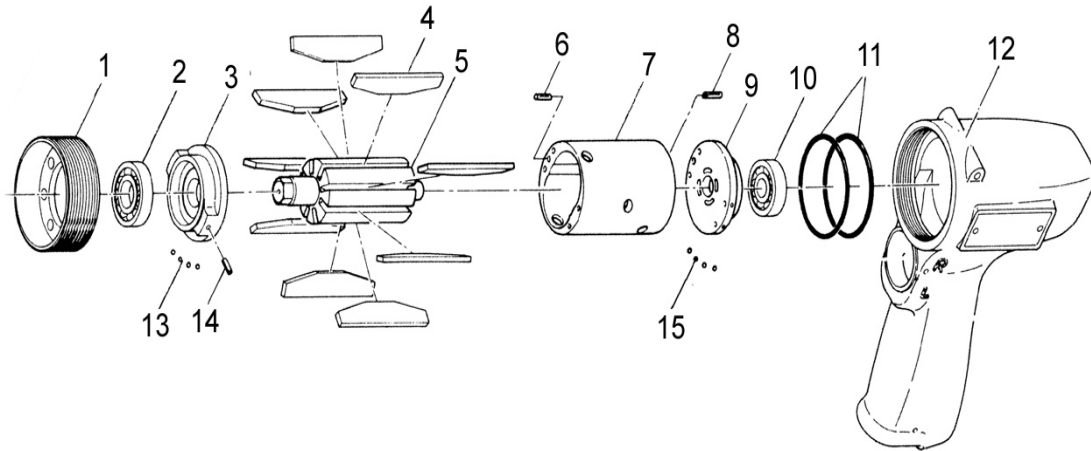

Part Number	Description	Part Number	Description
1	Casing Connector	9	Rear Plate
2	Front Plate Bearing	10	Rear Plate Bearing
3	Front Plate	11	O-Ring
4	Blades	12	Handle Casing
5	Rotor	13	Nylon Ball
6	Roll Pin	14	Roll Pin
7	Cylinder	15	Nylon Ball
8	Roll Pin		

Disassembly and Reassembly of the Air Motor Section (cont.)

B. UX & UX-T Pistol Grip Handles and Larger “S” & “C” Models

Disassembly

1. Remove the Front Casing and Pulse Unit. In the T-Series, remove the Spacer and Piston Rod.
2. Remove the Head Cover and Head Cover Packing. In the “C” model, remove the Handle and Handle Packing.
3. Press the Rear Plate and Rotor out the back of the Handle.
4. Remove the Front Plate Bearing.
5. Press the Rotor out of the Rear Plate Bearing and away from the Rear Plate.
6. If scarring on the Front Plate or excessive wear on the Cylinder is present, press the Front Plate and Cylinder out the rear of the Handle at the same time by using a Hydraulic Press.

Inspection

1. Same as in the UX-450 through UX-612 Air Motor Section.

Reassembly

1. Grease Rear Plate Bearing and press into Rear Plate and onto rear of Rotor at the same time.
2. There should be a small amount of drag between the Rear Plate and Rotor. Some adjustment may be necessary.
3. Grease the Front Plate Bearing and press into the Front Plate.
4. Oil blade and install into Rotor.
5. If the Front Plate and Cylinder were removed from the Handle, then slide the Cylinder down over the Rotor and onto the Rear Plate lining up the Port Holes and Roll Pin. Install the Front Plate bearing side-up, down over Rotor and onto the Cylinder.
6. For installation of the Rear Plate and Rotor only, hold the Handle in the vise with the Air Motor Section up. Heat the rear of the Handle for approximately one minute with a Propane Torch, and install the Rear Plate Rotor combination into the Handle, lining up the Roll Pin on the side of the Rear Plate with the Notch in the Handle.
7. When installing the Air Motor as an assembly, heat the Handle about two to three minutes with a Propane Torch. Now install the complete Air Motor into the Handle. Line up the Roll Pin in the side of the Rear Plate with the Notch in the Handle.
8. Install the Head Cover Gasket, Head Cover and the Allen head bolts. Loc-Tite all bolts with service removable Loc-Tite. Cross-tighten the bolts while rotating the Rotor with the Pulse Unit.
9. On the T-Series, install the Piston Rod and Spacer.
10. Install Front Casing and Pulse Unit.

Exploded View of the Air Motor (cont.)

UX Series

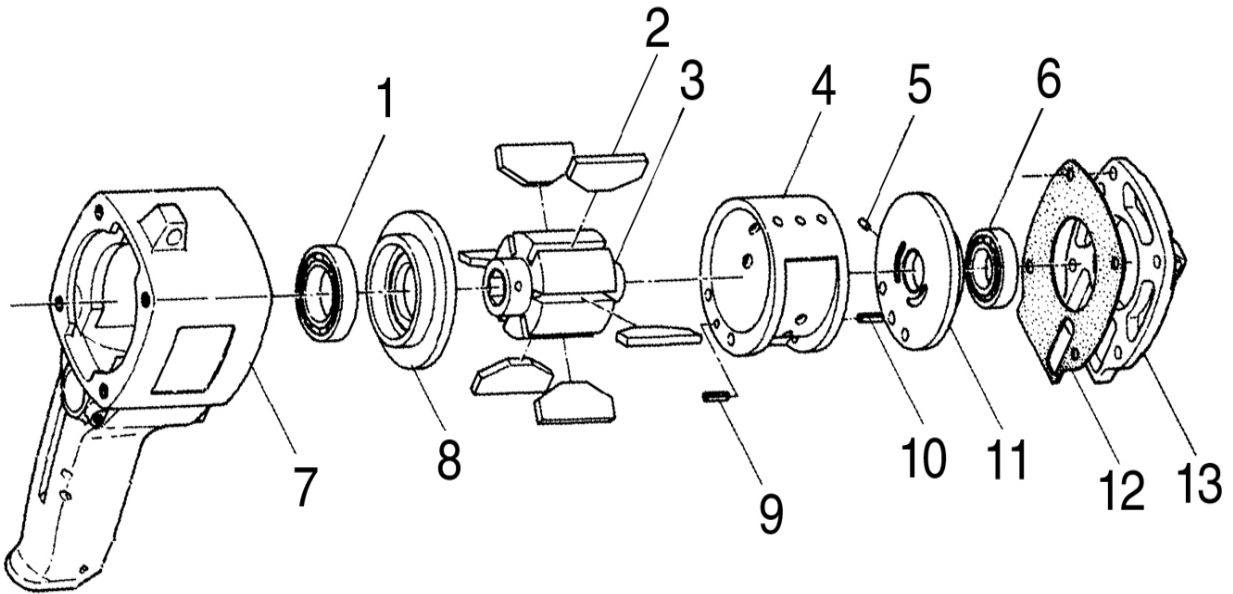

Part Number	Description	Part Number	Description
1	Ball Bearing	8	Front Air Motor Plate
2	Blade	9	Roll Pin
3	Rotor	10	Roll Pin
4	Cylinder	11	Rear Air Motor Plate
5	Roll Pin	12	Head Cover Packing
6	Ball Bearing	13	Head Cover
7	Handle		

Exploded View of the Air Motor (cont.)

UX-T Series

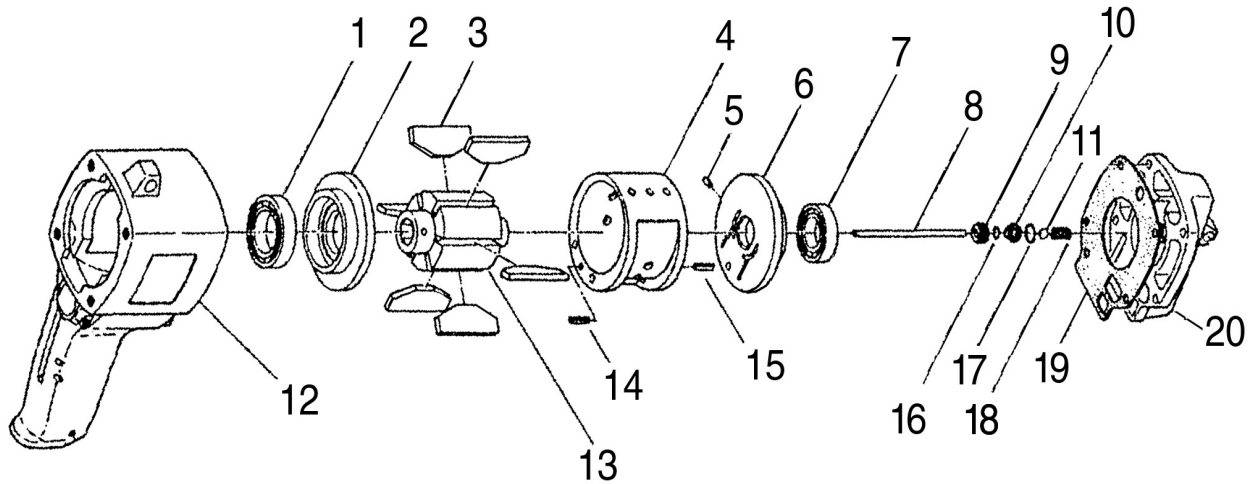

Part Number	Description	Part Number	Description
1	Ball Bearing	11	Steel Ball
2	Front Plate	12	Handle
3	Blades	13	Rotor
4	Cylinder	14	Roll Pin
5	Roll Pin	15	Roll Pin
6	Rear Plate	16	O-Ring
7	Ball Bearing	17	O-Ring
8	Piston Rod	18	Spring
9	Valve Cover	19	Head Cover Packing
10	Pilot Valve Setter	20	Head Cover

Disassembly and Reassembly of the Shut-off Section

UX-T

A. Disassembly of the Shut-off Section

1. Remove the Shut-off Valve Cover using a 17mm wrench and remove the Shut-off Valve and Spring.
2. Remove the Head Cover and Head Cover Packing.
3. Remove the Piston Rod, Valve Cover, Pilot Valve Retainer, Ball, Spring, and O-Rings. Some models have a Packing in the Shut-off Valve Bushing.

B. Inspection

1. **O-Ring**
 - a) Inspect for chipping, tears, and cuts. If damaged, replace.
2. **Packing**
 - a) Inspect for damage. If damaged, replace.

C. Reassembly

1. Install all O-Rings and Packings.
2. Install the Pilot Valve Spring and Ball into the Head Cover.
3. Install the Pilot Valve Retainer (with the small end up) and the Valve Cover into the Head Cover.
4. Install the Piston Rod, Head Cover Packing, and Head Cover onto the Handle Casing.
5. Install the Shut-off Valve Spring, Shut-off Valve, and the Shut-off Valve Cover onto the Head Cover.
6. The tool is now ready to test.

Exploded View of the Shut-off Valve Section

UX-T700 ~ T1820

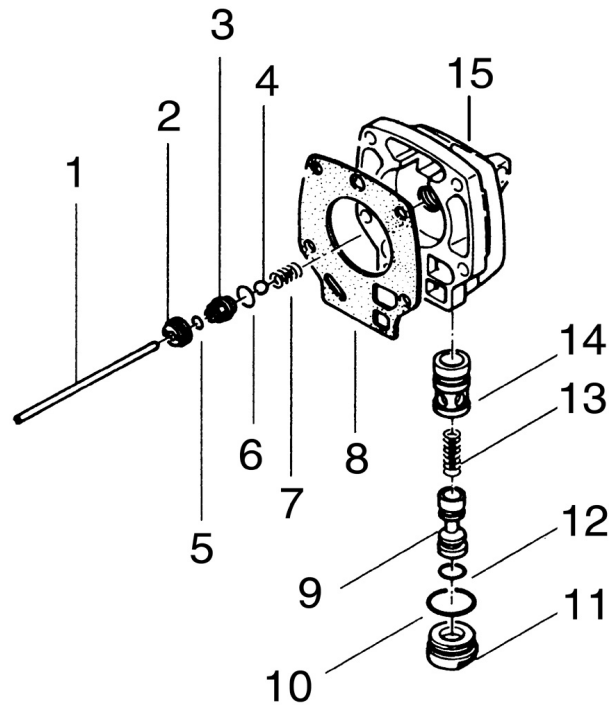

Part Number	Description	Part Number	Description
1	Piston Rod	9	Shut-off Valve
2	Valve Cover	10	Shut-off Valve Cover O-ring
3	Pilot Valve Retainer	11	Shut-off Valve
4	Pilot Valve Ball	12	Shut-off Valve O-Ring
5	Piston Rod O-Ring	13	Shut-off Valve Spring
6	Pilot Valve O-Ring	14	Shut-off Valve Bushing
7	Pilot Valve Spring	15	Head Cover
8	Head Cover Packing		

Repair and Adjustment of Angle Head Pulse Tool

CAUTION: Read all instructions thoroughly before repairing tool.

Safety:

- Disconnect the air supply from tool before repairing, adjusting torque, and changing sockets or extensions.
- Wear eye and hearing protection when using hammers or power tools.
- Do not wear loose clothing around power equipment.
- Dispose of all oil and grease properly.

A. Disassembly:

1. Remove the Allen Head Cone Point Screw, holding the Angle Head Casing Cover in place.
2. Remove the Angle Head Casing Cover, Driven Gear, Bushing, Spindle Spacers, and Bearings.
3. Remove the Angle Head Casing Assembly from the tool.
4. On the UX-612C to UX-900C, remove the four Allen Head Bolts, holding the Angle Head Casing to the front Casing.
5. On the UX-612C, 700C, and 1000C, remove the Allen Head Cone Point Screw, which holds the Driving Gear Bushing Screw in place, and remove the Driving Gear Bushing Screw. **NOTE:** On the UX-1000C, the Snap Ring and Bearing must be removed before you can remove the Driving Gear Bushing Screw.
6. Remove the Driving Gear, Bearings, Bushing, and Spacers from the Angle Head Casing.
7. Clean all parts and inspect for wear.

B. Inspection:

1. Inspect all Bearings for side play and knocking. Replace as needed.
2. Inspect Driven and Driving Gear for grooving and pitting. If present, replace as a set.

C. Reassembly:

CAUTION: All shimming of the Gear Lash is performed on the Driven Gear.

1. Grease all Bearings, Driven, and Driving Gears.
2. Install the Driving Gear, Spacer, Bearing, Bushing, Adjusting Spacer (if present when the tool was disassembled), and Bearing into the Angle Head Casing.
3. On the UX-612C, 700C, and 1000C, install the Driving Gear and Bushing Screw and line up the detent with the hole for the Allen Head Cone Point Screw. **NOTE:** Use a service-removable thread locker on the Allen Cone Point Screw.
4. On the UX-800C and 900C, install the Front Casing and four Allen Head Bolts. **NOTE:** Use a service-removable thread locker on the Allen Head Cone Point Screw.
5. On the UX-612C and 700C, install the Front Casing and four Allen Head Bolts. **NOTE:** Use a service removable thread locker on the Allen Head Bolts.
6. Install the Angle Head Casing onto the Air Motor.

Repair and Adjustment of Angle Head Pulse Tool (cont.)

7. Install the Spindle Gear Cover and Bearing into the front of the Angle Head Casing.
8. Install the Driven Gear Spacer and Bearing onto the Driven Gear.
9. Install the Driven Gear Spindle and Driven Gear Collar into the Driven Gear.
10. Install the Driven Gear, Adjusting Spacers (quantity may vary), and tighten the Angle Head Cover so that the Driven Gear turns freely with no up and down movement. **NOTE:** Adjusting Spacers come in different thicknesses, so be sure to order a larger quantity than needed.
11. If Driven Gear is binding, remove the Adjusting Spacer; if it moves up and down too much, add the Adjusting Spacer.
12. On the UX-612C, 700C, 800C, and 900C, drill a new detent hole in the Angle Head Casing Cover and secure with the Allen Head Cone Point Screw. **NOTE:** Use a service-removable thread locker on the Allen Cone Point Screw.

Exploded View of the Angle Head Section

UX-C Series

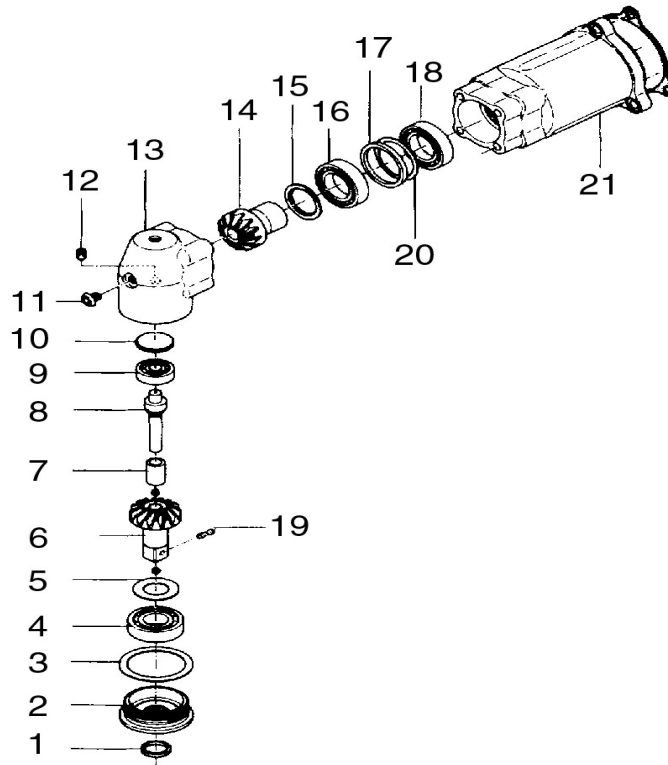

Part Number	Description	Part Number	Description
1	Felt Ring	12	Allen Head Cone Point Screw
2	Angle Head Casing Cover	13	Angle Head Casing
3	Adjusting Spacer	14	Driving Gear
4	Ball Bearing	15	Driving Gear Spacer
5	Driven Gear Spacer	16	Ball Bearing
6	Driven Gear	17	Driving Gear Bushing Spacer
7	Driven Gear Spindle Cover	18	Ball Bearing
8	Driven Gear Spindle	19	Retainer Pin Assembly
9	Ball Bearing	20	Adjusting Spacer
10	Spindle Rear Cover	21	Front Casing
11	Hexagon Round Head Plug		

Recommended Maintenance

Air Motor & Angle Head Section

The Air Motor should be cleaned and inspected every 300,000 cycles or six months, whichever comes first. Replace worn parts as needed.

The Angle Head Section should be cleaned and inspected every 300,000 cycles or six months, whichever comes first. Replace worn parts as needed.

Notes



Corporate Headquarters

10000 SE Pine Street
Portland, OR 97216
800-852-1368
FAX 800-582-9015
www.aimco-global.com

AIMCO Corporation de Mexico SA DE CV

Ave. Cristobal Colon 14529
Chihuahua, Chihuahua. 31125
Mexico
Phone: (01-614) 380-1010
Fax: (01-614) 380-1019

Global Assembly Solutions™

LIT-MAN500
Rev. 07/2020
Printed in USA
©2020 AIMCO