



# Gen IV Controller with Smart Arm Setup *Instruction Manual*



## Table of Contents

1. Introduction . . . . .	2
2 Equipment/Software. . . . .	2
3. Hardware Setup . . . . .	2
4. Hardware Connection . . . . .	3
4.1 Connecting the Encoders . . . . .	3
4.2 Encoder Compatibility . . . . .	3
4.3 Connecting the Remote Home . . . . .	3
5. Care Setup Steps Overview . . . . .	3
6. Functionality Overview . . . . .	3
7. Configuration of the Smart Arm Accessory . . . . .	4
7.1 Configuration Overview . . . . .	4
7.2 Accessory Setup . . . . .	4
7.3 Scanning and IP Setup Screen . . . . .	5
7.4 Main Configuration Screen. . . . .	5
7.5 Encoder Position Setup . . . . .	6
7.5.1 Homing . . . . .	6
7.5.2 Encoder Location Setup Screen . . . . .	6
8. Smart Arm Runscreen . . . . .	7
8.1 Add, Edit, or Delete Custom Images . . . . .	7
8.2 Associate an Image with a Job . . . . .	8
9. Examples . . . . .	9
9.1 Example 1: Select PSets Based on Location	10
9.1.1 PSet Setup . . . . .	10
9.1.2 Accessory Setup. . . . .	10
9.1.3 Add Image for Runscreen . . . . .	10
9.1.4 Icon Reference . . . . .	11
9.1.5 Clearing locations . . . . .	11
9.2 Example 2: Command Bolt Locations via External Source . . . . .	12
9.2.1 PSet Setup . . . . .	12
9.2.2 Job Setup . . . . .	12
9.2.3 Accessory Setup. . . . .	12
9.2.4 External Control . . . . .	13
9.2.5 Add Image for Runscreen . . . . .	13
9.2.6 Clearing locations . . . . .	14
10. Adding a Proximity or Limit Switch . . . . .	14
11. Icon Reference . . . . .	15
12. References . . . . .	15

## 1. Introduction

The Smart Arm Accessory allows an articulated arm with encoders to be used with the Gen IV controller. Fastener locations can be programmed into the controller so that the controller will perform specific actions when the tool is located on a specific fastener. The controller can also be configured to show a custom image on the Runscreen with fastener locations that update as fastenings are performed.

## 2 Equipment/Software

- AIMCO Gen 4 controller.
- Power Supply Cable.
- Smart Arm Accessory – Encoder Interface - 30860
- Ethernet Cable

## 3. Hardware Setup

- Connect power to the Gen IV controller
- Connect power to the Smart Arm Accessory
- Connect an Ethernet cable from the Accessory box to the second Ethernet port on the Gen IV Controller.
- Connect the encoders from the arm to the accessory box via M12 cables.
- Power up the Smart Arm Accessory
- Power up the Gen IV Controller



## 4. Hardware Connection

### 4.1 Connecting the Encoders

The encoders from the arm connect to the controller via M12 connectors. The pinout is shown below.

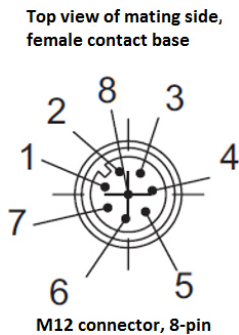

Encoder Circuit	M12-8 Bulkhead Connector Pin
0V	1
+12Vdc	2
A	3
B	5

### 4.2 Encoder Compatibility

The system is compatible with incremental encoders with the following specifications:

- Voltage: 12V
- Signal output: Quadrature with A B outputs
- Pulse rate: System verified with 2048 pulses per revolution and lower

### 4.3 Connecting the Remote Home

An external remote home button can be added to the accessory if needed. This will perform the same function as the 'Home' button on the accessory box. The homing function will be triggered when pin 4 on the M8 connection is pulled high to +12V.

External Circuit	M8-3 Bulkhead Connector Pin
0V	3
+12Vdc	1
Signal	4

## 5. Care Setup Steps Overview

This document covers the details of interfacing an arm outfitted with encoders to a Gen IV Controller. The general steps of the setup are:

1. Make all hardware connections
2. Power on the Smart Arm Accessory and Gen IV Controller
3. Configure the accessory IP settings from the controller
4. Add the Smart Arm accessory in the Gen IV controller settings
5. Configure the accessory settings and add arm locations
6. Add runscreen image (if required). Image must be 470 x 550 pixels for best fit to controller screen
7. Configure line side control (if required)

## 6. Functionality Overview

The Smart Arm Accessory can interface with an arm fitted with up to four encoders and/or proximity sensors. A runscreen can be configured to show fastener locations on a user uploaded image. The controller is able to read the arm position from the accessory box and perform an array of different functions based on arm position. Setup can be as simple as just selecting a PSet when the arm is positioned over a fastener. It can also be as complicated as combining line side control to determine which fastener to insert with a Job and Arm ensuring that the correct fastener is inserted in the correct sequence while preventing fasteners from being re-inserted.

Triggering the 'Job Reset' IO will clear the OK/NOK status of any fasteners.

## 7. Configuration of the Smart Arm Accessory

### 7.1 Configuration Overview

The smart arm and runscreen can be configured in many different ways to fit the user's needs. Almost any IO functionality works in conjunction with the smart arm display. The most common setups are shown below but a wider array of IO, Job, and Arm functions are available.

1. Arm position selects PSets
  - a. The controller changes PSet based on arm location. No fastening sequence is needed by the application. The screen will show all locations as valid positions to insert a fastener.
2. Job enabled, Arm selects job sequence
  - b. The sequence of inserting fasteners is determined by the arm. The job system will disable the controller if the arm is positioned over a fastener that is part of has already been completed. The locations on the screen will reset when the job is complete or the 'Job Complete' IO is triggered. This system also allows more flexibility with PSet choice. If a set of fastenings have different torque/angle requirements depending on if the part is new or being reworked then the job can be changed so a different set of PSets is associated with the same fastener locations.
3. Job enabled, IO Selects job sequence, Arm verifies job sequence
  - c. This setup works best if the line side control determines which fasteners can be inserted. The IO will select the job sequence and the controller will be disabled until the arm is positioned over a location in that job sequence. This is a good option when each fastener needs to be individually commanded to be run via IO.

Each job sequence can contain one fastener and the job sequence is equivalent to the location number. This way the smart arm position location number and parameter can be matched to the job sequence number. This way the same PSet can be used for multiple fasteners because the job sequence number is the value tied to the location number. The job number can be changed which allows different fastening parameters to be connected to the same locations.

### 7.2 Accessory Setup

To configure the Smart Arm Accessory, from the main Gen IV controller screen, select "Accessories."

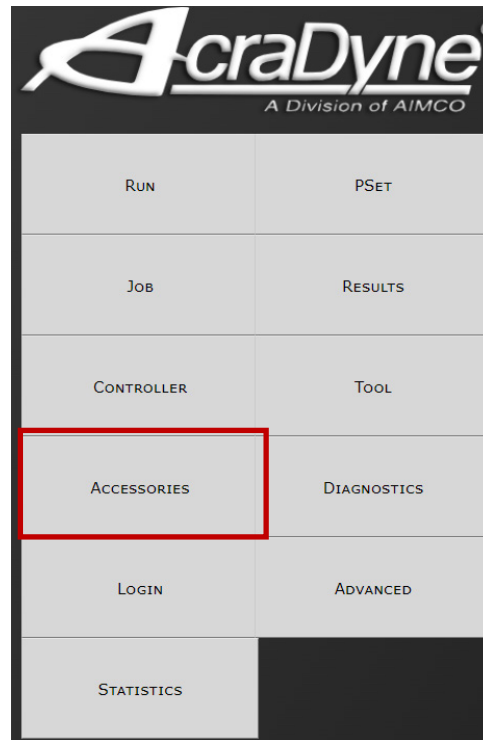

This will open the main Accessory screen.

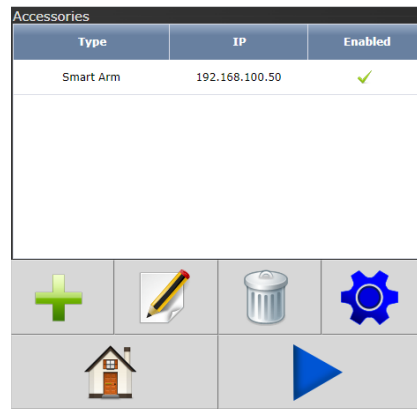

This screen shows accessories recognized by the controller. New accessories can be added, edited, and deleted using the buttons at the bottom of the table. Select either or to navigate to the Accessory Scanning and Setup page.

## 7.3 Scanning and IP Setup Screen



This screen is used to configure the IP settings of the accessory. Clicking the magnifying glass will search for AcraDyne Accessories on the network. Any accessories found will show up in the list. Click on the accessory to be configured to edit its settings. Once clicked, the current settings will autofill in the edit fields. Edit these and click 'Send' to send the new settings to the accessory that matches that MAC address. Ensure that the accessory being modified is the intended accessory by matching the MAC address on the screen to the MAC address labeled on the accessory box.

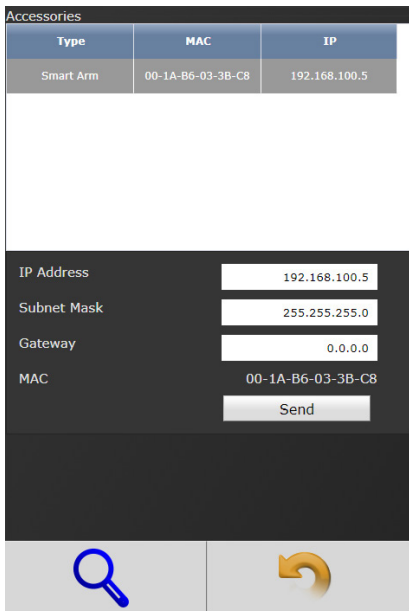

## 7.4 Main Configuration Screen

To configure the smart arm accessory, select it from the Accessory Setup Screen and select Edit 

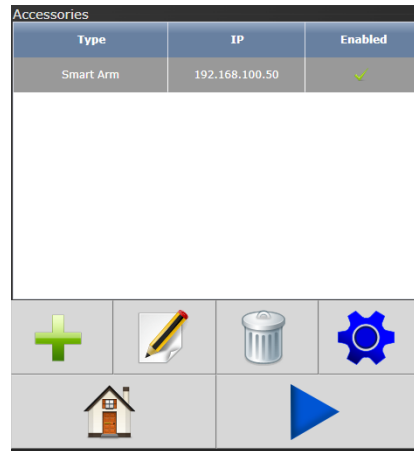

The Main Configuration/Primary Setup screen will appear.

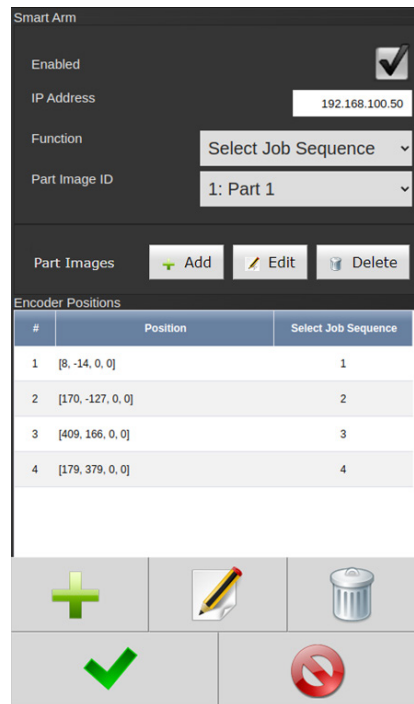

The primary setup screen contains the basic settings for what action will be taken when the arm is in position and a list of valid locations. Settings are not saved until the OK/Check button is clicked.

- **Enabled:** Toggles whether the smart arm accessory is active. If this is unchecked then the smart arm will not control the enabled state of the tool
- **IP Address:** This is the IP Address of the smart arm accessory that was set up in "7.3 Accessory Scanning and IP Setup Screen" on page 5

- **Function:** Selects what action the smart arm position activates. Options include
  - Select Pset
    - This will pair a location to a PSet and the controller will select the PSet when this location is matched
  - Verify Pset
    - The tool will be disabled until the PSet is selected that matches the required PSet from the location configuration
  - Select Job Sequence
    - This will pair a location to a job sequence. The controller will select a specific job sequence when the location is matched
  - Verify job Sequence
    - The tool will be disabled until the correct job sequence is selected that matches the job sequence from the location configuration
- **Part Image ID:** Shows a list of images that have been added
- **Part Images:** This section allows you to add, edit or delete custom images for the Smart Arm Runscreen. See instructions in "8. Smart Arm Runscreen" on page 7
- **Encoder Positions:** List of saved smart arm locations. See following section for instructions on setting up locations.

## 7.5 Encoder Position Setup

To begin setting up encoder positions, start by homing the arm position.

### 7.5.1 Homing

- Pressing the 'Home' button on the accessory will set the '0' position of the arm. All locations will be referenced off this position. This can be the location of a specific bolt or another position in the station that has a fixed location.
- The system will need to be 'homed' whenever the station is powered up.
- The encoder accessory has an M8 connector that allows for a remote homing button to be wired in if the homing button on the box is inconvenient.
- After the system is homed then locations can be programmed via the Accessories->Smart Arm configuration page.

Encoder positioning can be set with or without an associated image. Although not required, uploading a custom image allows you to visualize the fastening locations of your project on the Smart Arm Runscreen.

### 7.5.2 Encoder Location Setup Screen

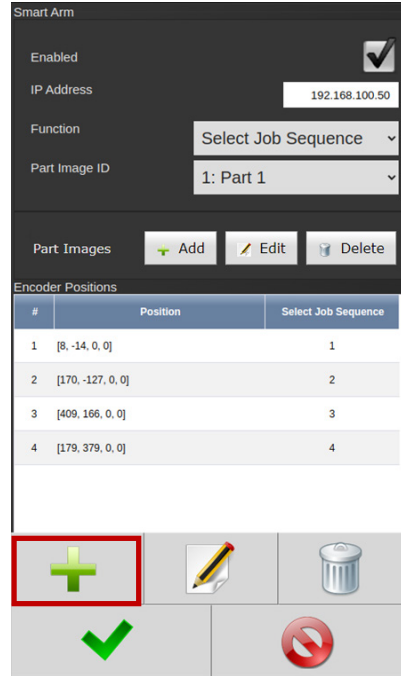

To enter the encoder location setup screen, select  from the main smart arm configuration screen.

The encoder location screen will appear.

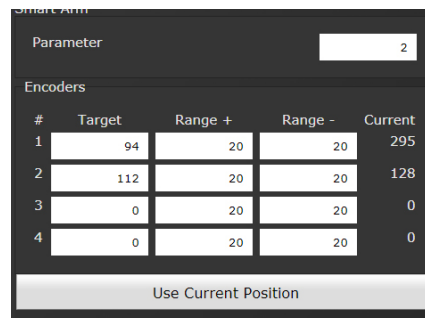

This screen is where a new location is configured. Locations are defined by encoder counts.

- **Parameter:** The 'Parameter' field is a multi-purpose field. This field corresponds to the Function option (see "Function" on page 6) so this field can correspond to PSet or Job Sequence number.
- **Target:** Target location
- **Range:** These fields define the window around the target that is acceptable for enabling that location. Reducing the range narrows the acceptability window and increasing the range widens the window. The software will show an error if any encoder locations overlap.
- **Current:** The right column labeled 'Current' shows the current state of the encoders being read from the Arm.
- **Use Current Position:** Selecting this option will grab the current state of the encoders and use it as the target. Use this to easily add a location by positioning the tool on the bolt and clicking 'Use Current Position.' Click OK at the bottom of the screen and this location will be added to the list.

## 8. Smart Arm Runscreen

Uploading a custom image allows you to visualize the fastening locations of your project on the Smart Arm Runscreen. This feature was added in SYSREL 3R18 (Application version 1.95)

The basic steps to set up the runscreen are:

1. Perform all steps previously shown to connect to the smart arm, add all fastener locations, and determine whether the arm position changes pset/job sequence/etc.
2. Upload an image that will show the locations of fasteners. Image must be 470 x 550 pixels for best fit to controller screen
3. Associate the fastener locations to locations on the image

### 8.1 Add, Edit, or Delete Custom Images

#### • Add Image

Click 'Add' to upload a custom image for the runscreen. This opens the part image upload page. Images must be 470 x 550 pixels for best fit to controller screen.

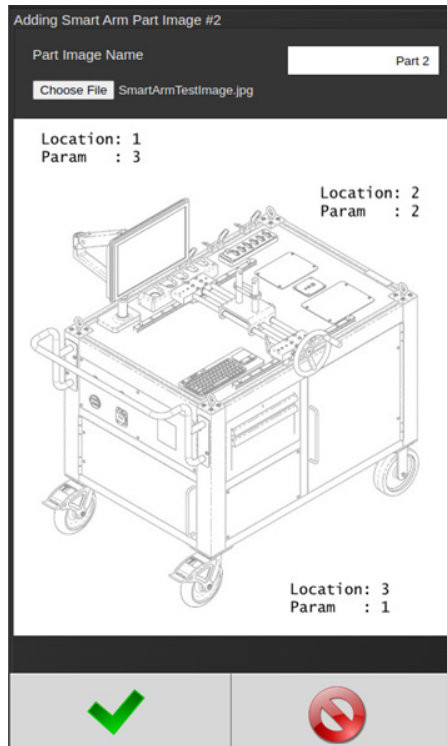

Enter a unique identifier as the Part Image Name and click "Choose File" to navigate to and select the custom image file. Image will appear on the screen.

#### • Edit Image

From the Main Configuration Screen, select the "Part Image ID" of the part you want to edit, then click "Edit."

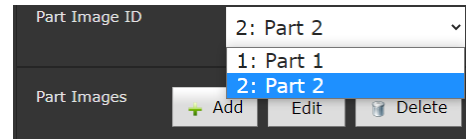

The Editing screen will appear

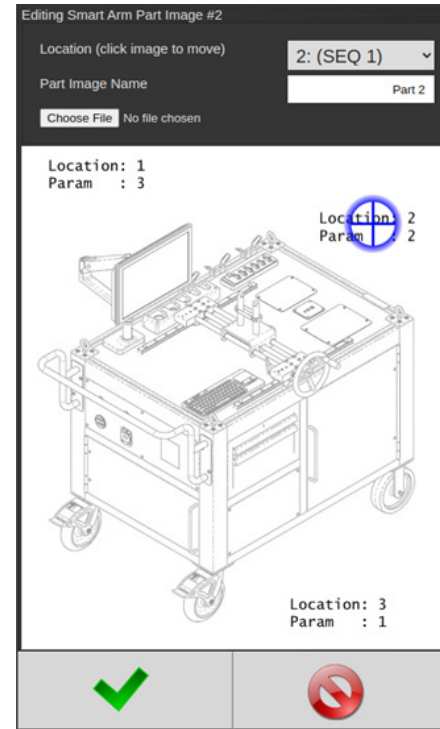

Edit as necessary (for instructions, see "8.1.3 Add Image for Runscreen" on page 10), then click  to return to the Main Configuration Screen.

#### • Delete Image

From the Main Configuration Screen, select the "Part Image ID" of the part you want to edit, then click "Delete." Deleting an image is permanent and doing so will delete all encoder positions/ location data. Click  to permanently delete the image.

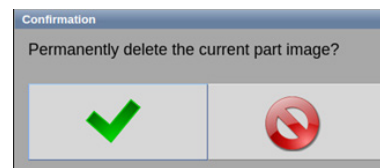

## 8.2 Associate an Image with a Job

Once a smart arm accessory and part images have been set up, you can associate a job with a specific smart arm part image in the controller's Job interface. This image will automatically appear when that job is chosen.

From the Main Gen IV Controller Screen, select Job

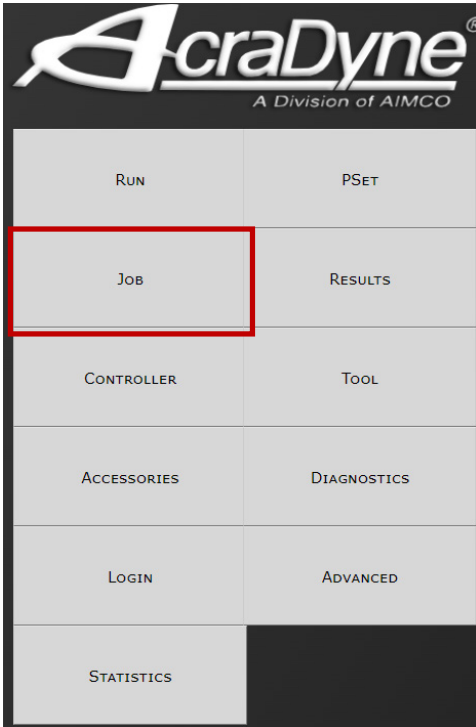

The jobs screen will appear. Select the job that you want to associate with an image, then select edit

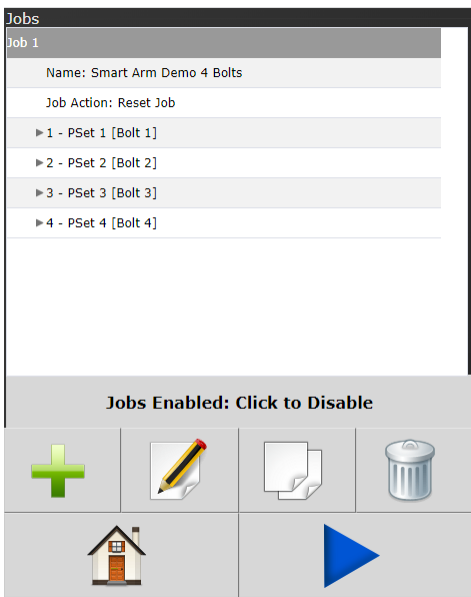

On the Edit Job screen, select Advanced Options

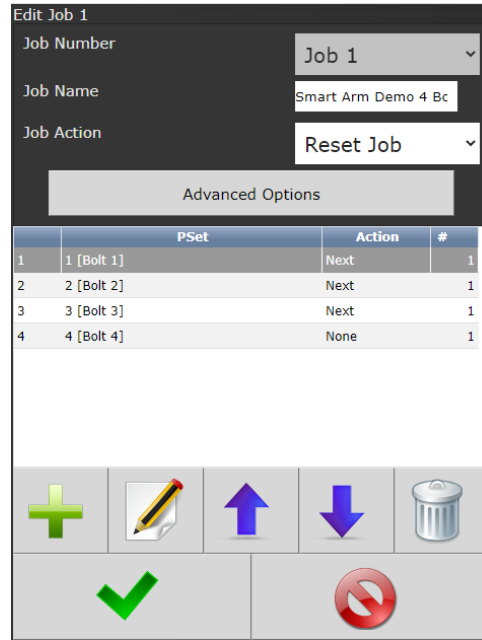

The following screen will appear

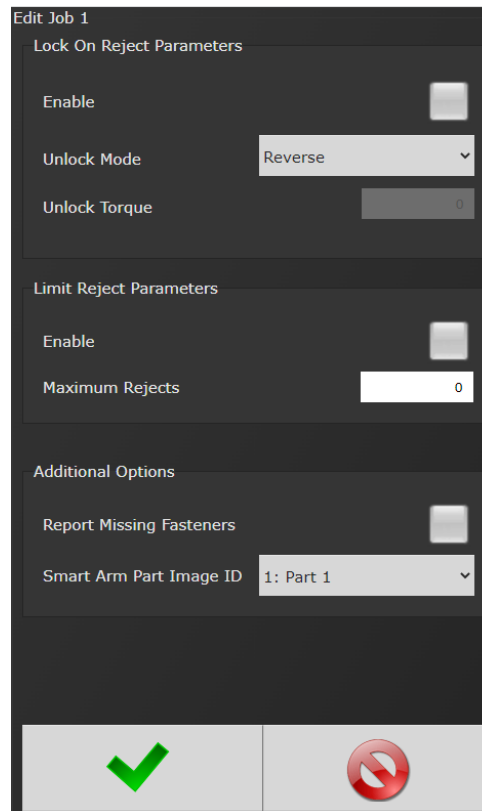

Under Additional Options, select the part image you want to associate with the job. Click ✓ when finished. Click ✓ again to return to Jobs screen.



The Jobs screen gives the option to Enable or Disable jobs. Click to toggle between the two.

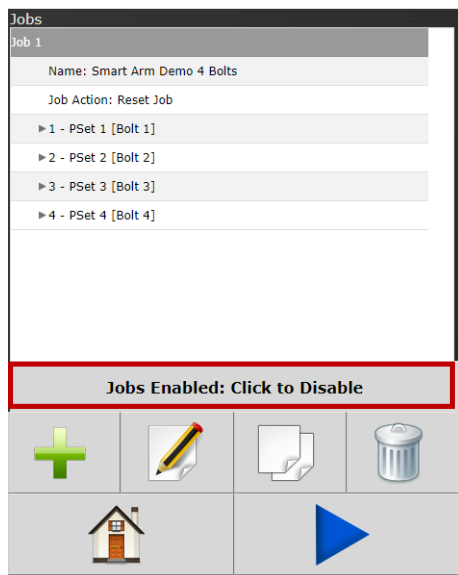

## • **Jobs Enabled**

Smart arm configuration will be automatically updated to the part image ID chosen through this jobs interface.

## • **Jobs Disabled**

Smart arm configuration will be updated to the image uploaded through the main smart arm interface. See "8.1 Add, Edit, or Delete Custom Images" on page 7.

## 9. Examples

For the examples given below, set up the controller and smart arm as follows.

### **Smart Arm Accessory Connections**

- 4x Encoder Connections – M12
  - Connect each encoder to an encoder connector starting at encoder 1
- 1x Remote Home Button Connection – M8
- Ethernet

### **Gen IV Controller Connections**

- Use second ethernet port to connect to accessory

### **Initial Setup: Configuring the Controller to Communicate with the Accessory**

- Configure the second ethernet port on the controller
  - This example is set up to work with the default IP settings on the second ethernet port of the controller
    - Controller IP Address: 192.168.100.1
    - Subnet: 255.255.255.0

- Set up the accessory ethernet settings
  - Go to the Accessory screen and click the gear icon
  - The accessory attached to the second ethernet port will appear in the list
  - Verify the MAC address shown matches the MAC printed on the accessory box.
  - Click on the accessory in the list and the edit fields below will autofill
  - Configure the accessory to have the following settings:
    - IP Address: 192.168.100.5
    - Subnet: 255.255.255.0
    - Gateway: 0.0.0.0
  - Click 'Send'
  - The accessory list will refresh and the accessory will show with its new settings.
- Add the smart arm accessory
  - Navigate to the main accessory screen and click Add(+)
  - Enter the IP address that was just configured for the accessory
    - IP Address: 192.168.100.5
  - Click OK/Check
- Verify connection
  - Runscreen status header
    - The main runscreen will now show an arm icon indicating that it is not in a valid location
  - Live encoder values
    - Navigate to Accessories and edit the smart arm accessory
    - Click the Add(+) button to add a new location. The fields under 'Current' should change as the arm is moved. This shows that the accessory is sending over valid encoder values.

## 9.1 Example 1: Select PSets Based on Location

This example shows how to set up the most basic control option. Three locations will be programmed in the controller so that the controller will enable the tool and select a specific PSet when the tool is located over a fastener.

### 9.1.1 PSet Setup

Create three PSets. These can be named in the advanced settings to make it more clear which PSet is for which bolt.

### 9.1.2 Accessory Setup

Navigate to the Accessories screen, select the Smart Arm accessory configured in the 'Initial Setup' portion and click the edit button.

Set up the accessory function as 'Select PSet'. This allows the controller to select the correct PSet for the arm location.

Before adding locations be sure to move the arm to the home position and press the 'Home' button on the accessory box. This will be the reference position for all added locations.

Add three fastener locations. Click the Add(+) button to add a new location. Move the tool onto the first fastener. The encoder values in the 'Current' column will update with the encoder counts for this position. Click 'Use Current Position' to use the current arm position for the location. Set the 'Parameter' field to 1 to select PSet 1 for this position. Click OK/Check to save this position.

Repeat this sequence for fasteners 2 and 3. Set PSet 2 for location 2 and PSet 3 for location 3. Click the OK/Check button on the main Smart Arm configuration screen to save all the location.

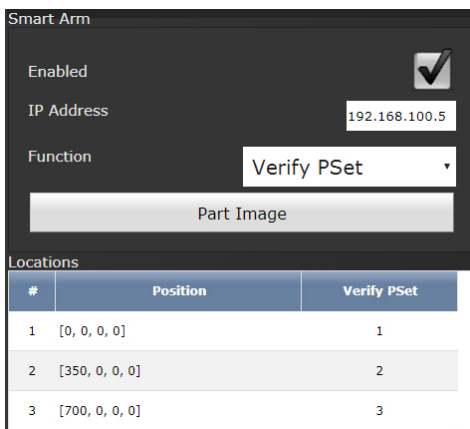

The controller will now select the correct PSet when it is located over a defined location. Once located over the fastener all Smart Arm stops will be cleared, the correct PSet

will be selected, and the tool will become enabled.

## 9.1.3 Add Image for Runscreen

### 9.1.3.1 Upload the Image

Click on the 'Part Image' button on the Smart Arm configuration screen and then 'Choose File' from the image selection screen. The image can be uploaded from a USB drive from the controller touch screen or uploaded from a PC when accessing the controller over a web connection. Image must be 470 x 550 pixels for best fit to controller screen.

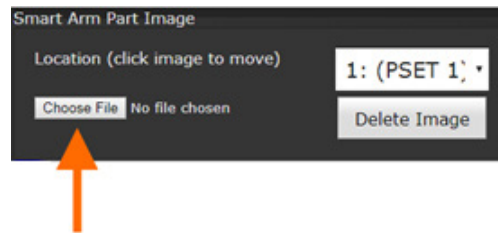
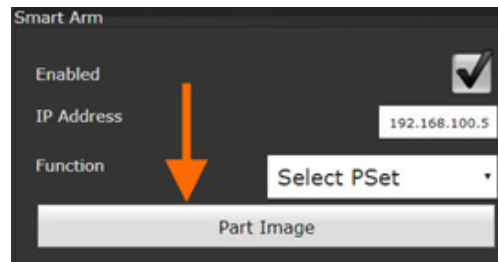

### 9.1.3.2 Add Locations on the Image

Once an image is selected it will show up in the space below. Now select a previously set up location from the top right and then select the space to associate with that location. Do this for every location and then save. Save again on the Smart Arm configuration screen.

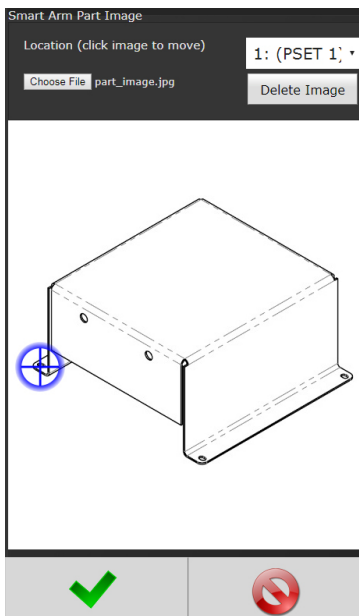

**Image 1**  
Adding locations # 1

### 9.1.3.3 Runscreen Behavior

Return to the main Gen IV runscreen and click left/right arrows until the screen with the part image is shown. The system is now set up to allow the controller to change psets based on the arm position. All valid positions will be blinking with a green target. When the arm encoder values match an associated location then the active location will turn blue indicating the current position and the active PSet will change.

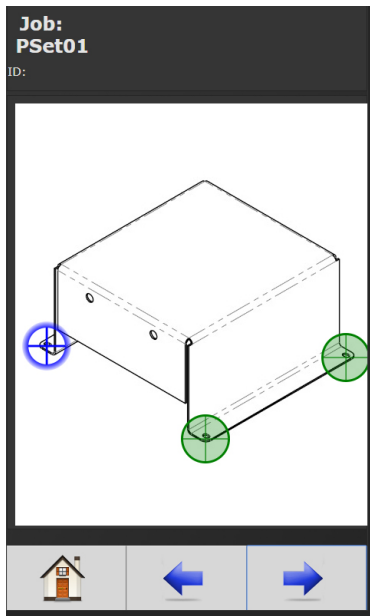

**Image 2**  
Current valid position is marked blue. Other valid locations marked with green targets.

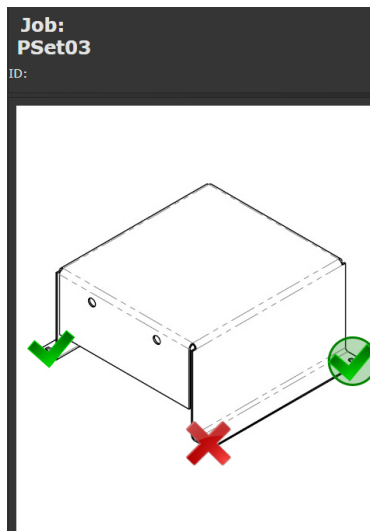

**Image 3**  
Fasteners are marked as they are completed. Failed fastenings are marked NOK. Status icons will clear when all fasteners have been successfully inserted.

### 9.1.4 Icon Reference

Icon	Function	Definition
	Current Location	The encoder states match the encoder location tied to this smart arm screen location
	Valid Location	This location is a valid position to move the arm to enable the tool.
	Invalid Location	This is a position that is registered but the tool will not be enabled when the arm is in this location. The IO or Job is commanding that a different position be run.
	Location OK, Current Location	A rundown has been successfully run in this position and the arm is currently positioned in this location
	Location NOK, Current Location	A rundown has failed in this position and the arm is currently positioned in this location.
	Location OK	A rundown has been successfully run in this position
	Location NOK	A rundown has failed in this position

### 9.1.5 Clearing locations

The 'Reset Job' input will always clear the Smart Arm Runscreen. Any positions marked as complete will be reset.

## 9.2 Example 2: Command Bolt Locations via External Source

This example shows how to set up a more complex control scheme. This application will have the following requirements:

- Three fasteners
- Each fastener has two unique tightening specifications
  - Initial work
  - Re-work

This application will use jobs to select the work type (initial or rework) and then select a job sequence number that is tied to the fastener number. Two jobs will be created (initial and re- work). Each job will have three job sequences (one for each fastener). Each of the three fasteners have two tightening specs so this gives six PSets. Job 1 will use PSets 1-3 for the 'Initial' work PSets, and Job 2 will use PSets 4-6 for 'Rework' PSets.

### 9.2.1 PSet Setup

Set up six PSets. These can be named in the advanced settings to make it more clear which PSet is for which bolt.

### 9.2.2 Job Setup

Set up two Jobs. Name Job 1 as 'Initial' and Job 2 as 'Rework'.

In job 1 set up the job sequence as the following

- Sequence 1: PSet 1
  - Action: None
  - Count: 1
- Sequence 2: PSet 2
  - Action: None
  - Count: 1
- Sequence 3: PSet 3
  - Action: None
  - Count: 1

The setup should result in a job that is shown below.

	PSet	Action	#
1	1 [3Nm]	None	1
2	2 [2.99Nm]	None	1
3	3 [2.98Nm]	None	1

In job 2, set up the job sequence as the following:

- Sequence 1: PSet 4
  - Action: None
  - Count: 1
- Sequence 2: PSet 5
  - Action: None
  - Count: 1
- Sequence 3: PSet 6
  - Action: None
  - Count: 1

The setup should result in a job that is shown below.

	PSet	Action	#
1	4 [3Nm]	None	1
2	5 [2.99Nm]	None	1
3	6 [2.98Nm]	None	1

### 9.2.3 Accessory Setup

Navigate to the Accessories screen, select the Smart Arm accessory configured in the 'Initial Setup' portion and click the edit button.

Set up the accessory function as 'Verify Job Sequence'. This allows an external system to select the job number and job sequence number to define which fastener needs to be run and whether it should be from the 'Initial work' job or the 'Rework' job.

Add three fastener locations. Click the Add(+) button to add a new location. Set 'Parameter' to 1 so that job sequence 1 needs to be selected for the tool to be enabled. Move the tool onto the fastener for this location. Click 'Use Current Position' to populate the target fields with this locations encoder values. Click OK/Check. Repeat this for location 2 and 3. Set 'Parameter' to 2 for location 2 and 3 for location 3. Click OK/Check until all Smart Arm configurations are saved.

Each location is now paired with a job sequence number. Now configure the line side control to select the job and job sequence paired to the fastener and the tool will not be enabled until the tool is located over the correct fastener.

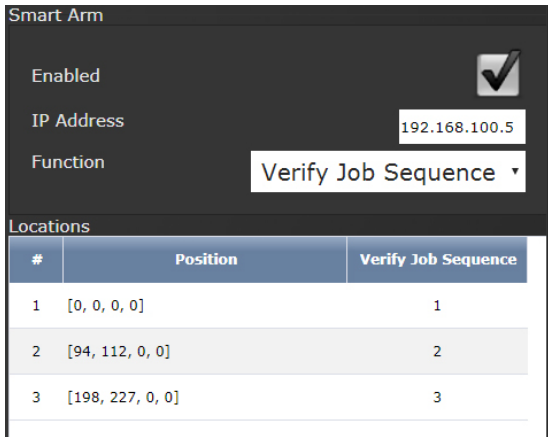

## 9.2.4 External Control

Line side control can be used to command which fastener needs to be run. Select the Job that matches the work type (initial or rework) and select the job sequence number that is tied to the fastener location. Configure the assignable IO for the required interface type (CC-Link, Anybus, etc.) to select a job number and job sequence number. Refer to the white paper for the specific interface for configuration details.

In this example, selecting Job 1 and Job Sequence 2 will select PSet 2 and disable the controller until the arm is in the correct position for fastener 2.

Selecting Job 2 and Job Sequence 3 will select PSet 6 and disable the controller until the arm is in the correct position for fastener 3.

The front panel and physical IO can be used to select job number, sequence number, and reset job if needed for testing. The job can be changed by holding the toggle button and pressing an up/down button. Job sequence can be changed by just pressing an up or down button when jobs are enabled.

## 9.2.5 Add Image for Runscreen

Add the image and three locations as shown in "9.1 Example 1" on page 10.

### 9.2.5.1 Runscreen Behavior

Return to the Gen IV Runscreen and navigate to the screen with the part image. The image will now direct the user to fasten the bolt that is being commanded from the 'Select Job Sequence' input.

The next images show what happens when the Arm is over location 1 but the commanded Job Sequence from IO changes from 1, 2, and then 3.

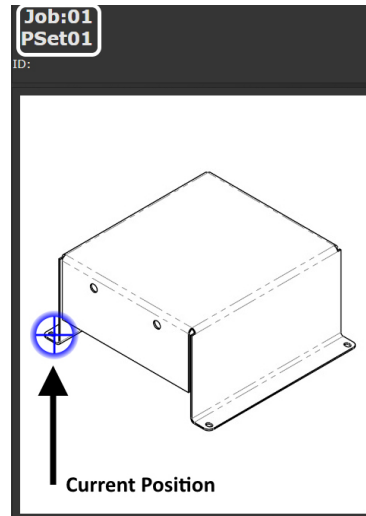

**Image 4**

Job Seq 1 is selected. Arm is in correct position.

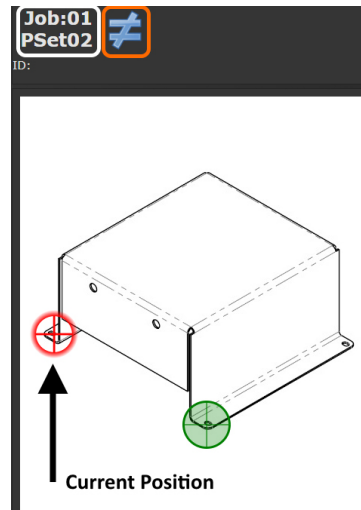

**Image 5**

Job Seq 2 is selected. Arm is in position 1 (shown in red as incorrect position) and screen shows green target highlighting fastener to be inserted. Stopped icon appears showing that the tool is disabled.

## 10. Adding a Proximity or Limit Switch

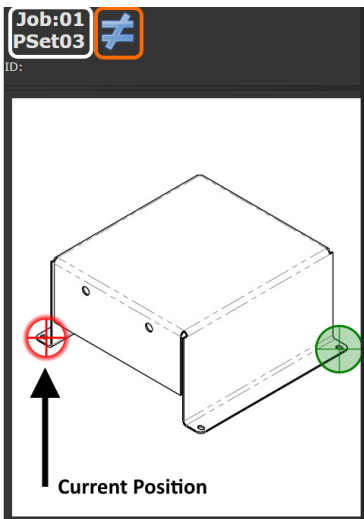

**Image 6**  
Job Seq 3 is selected. Arm is in position 1 (shown in red as incorrect position) and screen shows green target highlighting fastener to be inserted. Stopped icon appears showing that the tool is disabled.

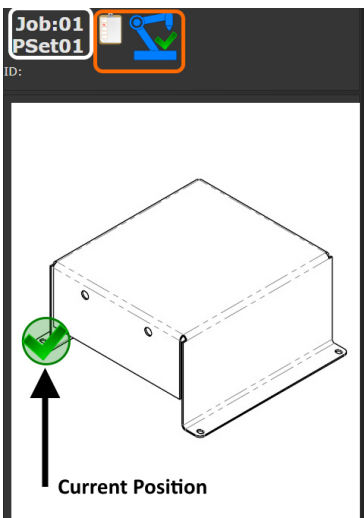

**Image 7**  
First fastener has been inserted successfully. Current position is marked OK. Status bar shows 'Job Sequence Complete' and 'Location Complete'.

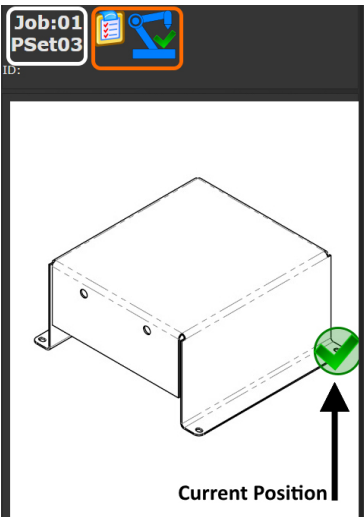

**Image 8**  
All fasteners inserted. Tool is disabled. Status bar shows job complete. Reset job to start new part.

For a description of icons, see "Icon Reference" on page 11

### 9.2.6 Clearing locations

The 'Reset Job' input will always clear the Smart Arm Runscreen. Any positions marked as complete will be reset.

A proximity switch or limit switch can be wired in to one of the encoder inputs. This will allow one of the encoder readings to read as 0/1 or 0/-1 depending on how the switch is wired. The switch will always read one of two states so the range for that encoder will need to be set to 0. For the configuration in the image below the 3rd encoder is set to work with a proximity switch. The location is only valid when the encoder is reading a -1. The range is 0 so that the target has to be an exact match.

Smart Arm

Parameter





Encoders

#	Target	Range +	Range -	Current
1	0	20	20	8
2	0	20	20	6
3	-1	0	0	0
4	0	20	20	0

Use Current Position

Use the pinouts in "Hardware Connections" to wire in the proximity switch to an M12-8 connector. Use 0V (pin 1) and 12V (pin 2) to power the switch and connect the signal wire to the 'A' input (pin 3)

## 11. Icon Reference

Icon	Function	Definition
	Position not valid	The current position of the arm does not match any locations in the smart arm configuration. This error will clear when the arm is in a valid position.  'SARM' will show on the top LED display.
	Location Complete	This will appear when Jobs are enabled and the current location has already had an OK fastening.  Only appears when the custom runscreen image is configured.  'SARM' will show on the top LED display.
	PSet or Job Sequence Mismatch	The currently selected PSet or Job Sequence does not match the PSet or Job Sequence number required by the current location. This error will clear when one of the following happens: <ul style="list-style-type: none"> <li>The arm moves to a position that requires the currently selected PSet/Sequence</li> <li>The active PSet/Sequence is changed to match what is required for this position</li> </ul> 'PSET' or 'JSEQ' will show on the top LED display.
	Connection Error	The controller is not communicating with the accessory. Commonly caused by incorrect IP settings in the controller or accessory.  'SARM' will show on the top LED display.

## 12. References

- 30887 – Smart Arm Assembly
- Encoder - Kubler 8.3620.525E.2048
- 30860 - Smart Arm Accessory – Encoder Interface



**AIMCO CORPORATE HEADQUARTERS**  
10000 SE Pine Street  
Portland, Oregon 97216  
Phone: (503) 254-6600  
Toll Free: 1-800-852-1368

**AIMCO CORPORATION DE MEXICO SA DE CV**  
Ave. Cristobal Colon 14529  
Chihuahua, Chihuahua. 31125  
Mexico  
Phone: (01-614) 380-1010  
Fax: (01-614) 380-1019