

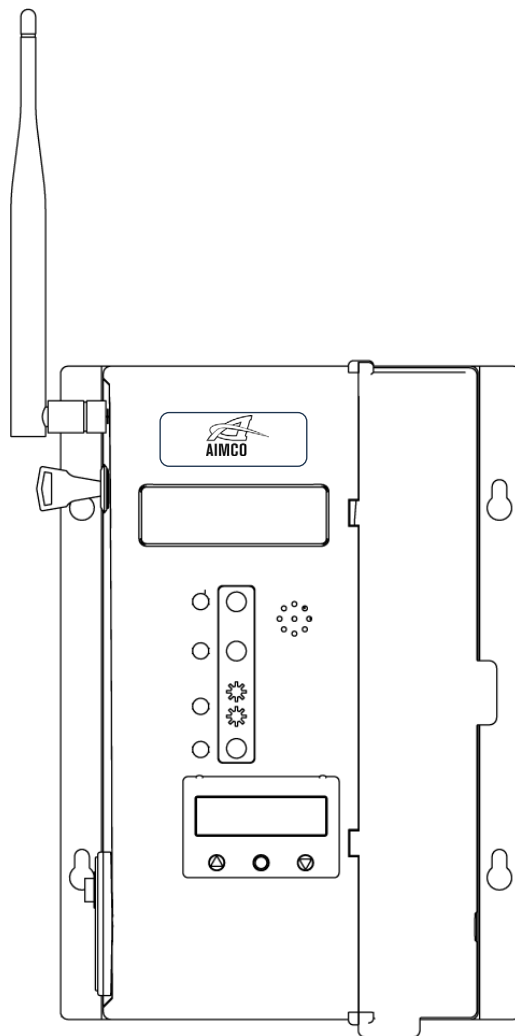

Instruction Manual

Signature Series

DWL-B Wireless Receiver for Transducerized SPT Series Tools



Introduction

This document primarily explains how to set up the tool pairing connection, operate the DWL-B wireless system receiver, transmit data to the back end (PC or server), and connect with the Programmable Logic Controller (PLC) on the production line to achieve the purpose of production line control.

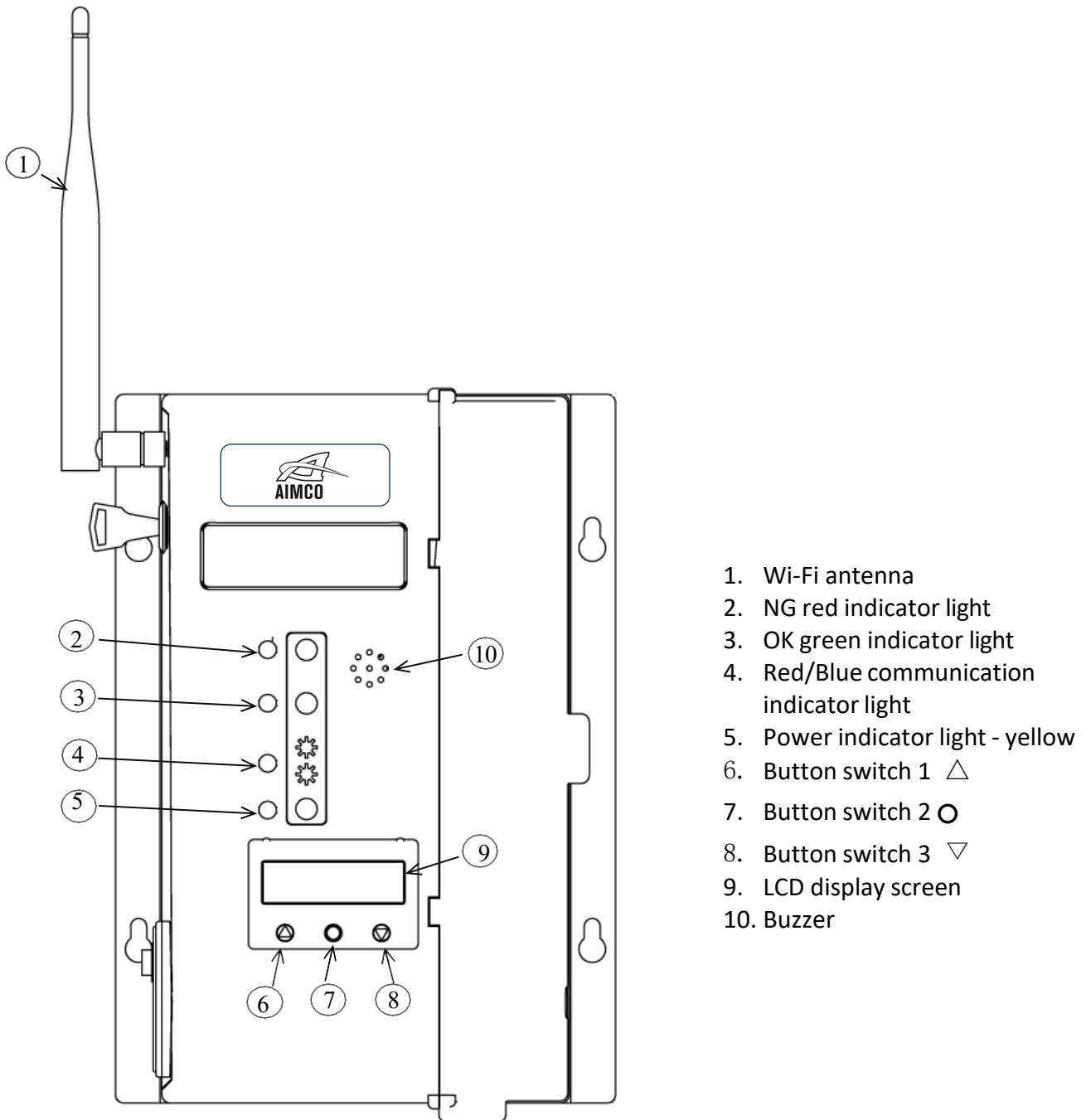

Fig 1 Product Features

1. Installation

Locate the screw holes on the mounting plate of the DWL-B (Figure 2). Fix the aluminum plate to the wall by with screws.

Please refer to the dimensional information on the drawing for the hole spacing for the lock attachment screws. Install the receiver in a stable and safe area.

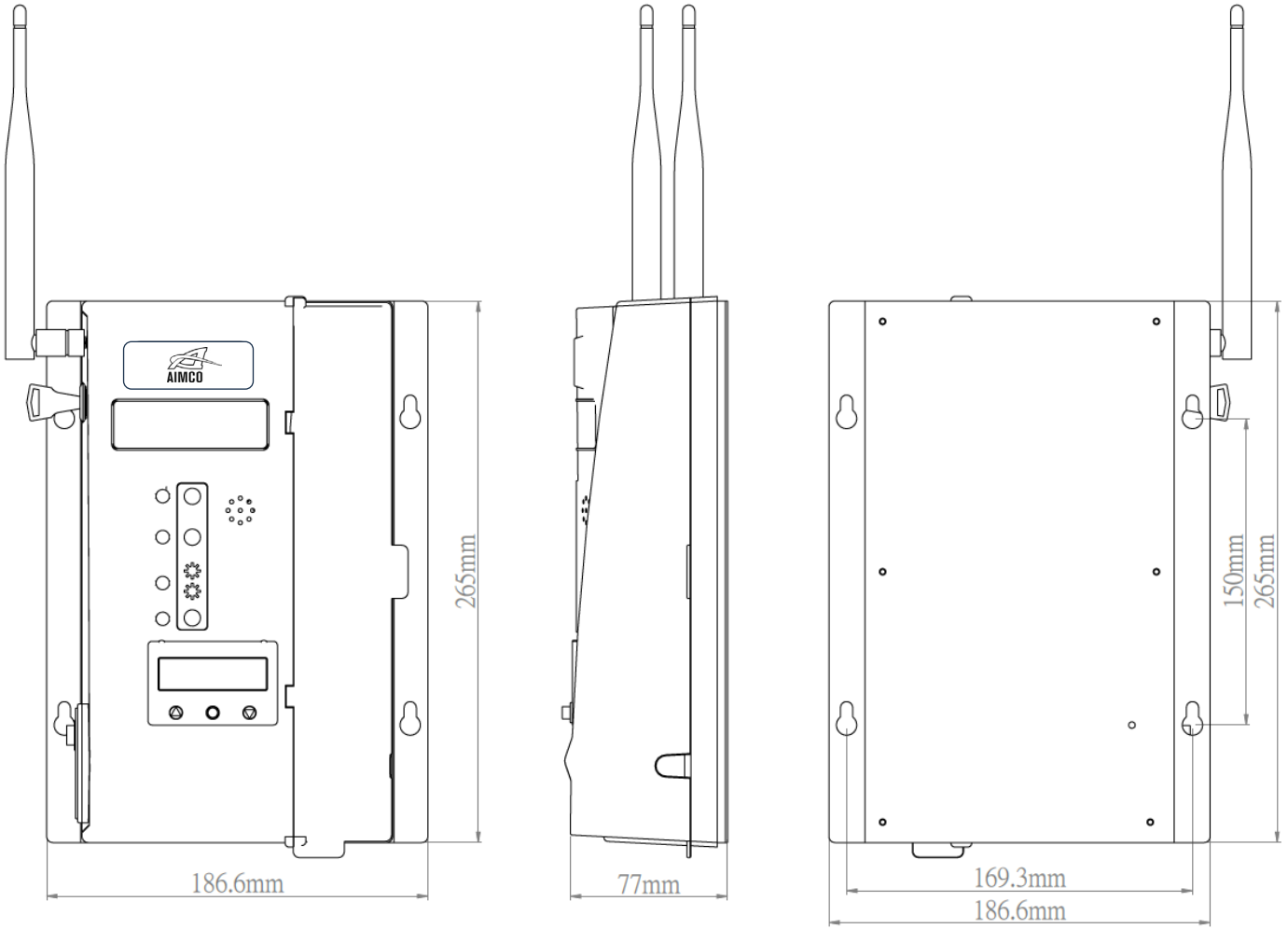

Fig 2

2. Connecting the I/O devices.

The I/O connection points of the DWL-B wireless receiver are at both sides of the receiver box, as shown in Figure 3.

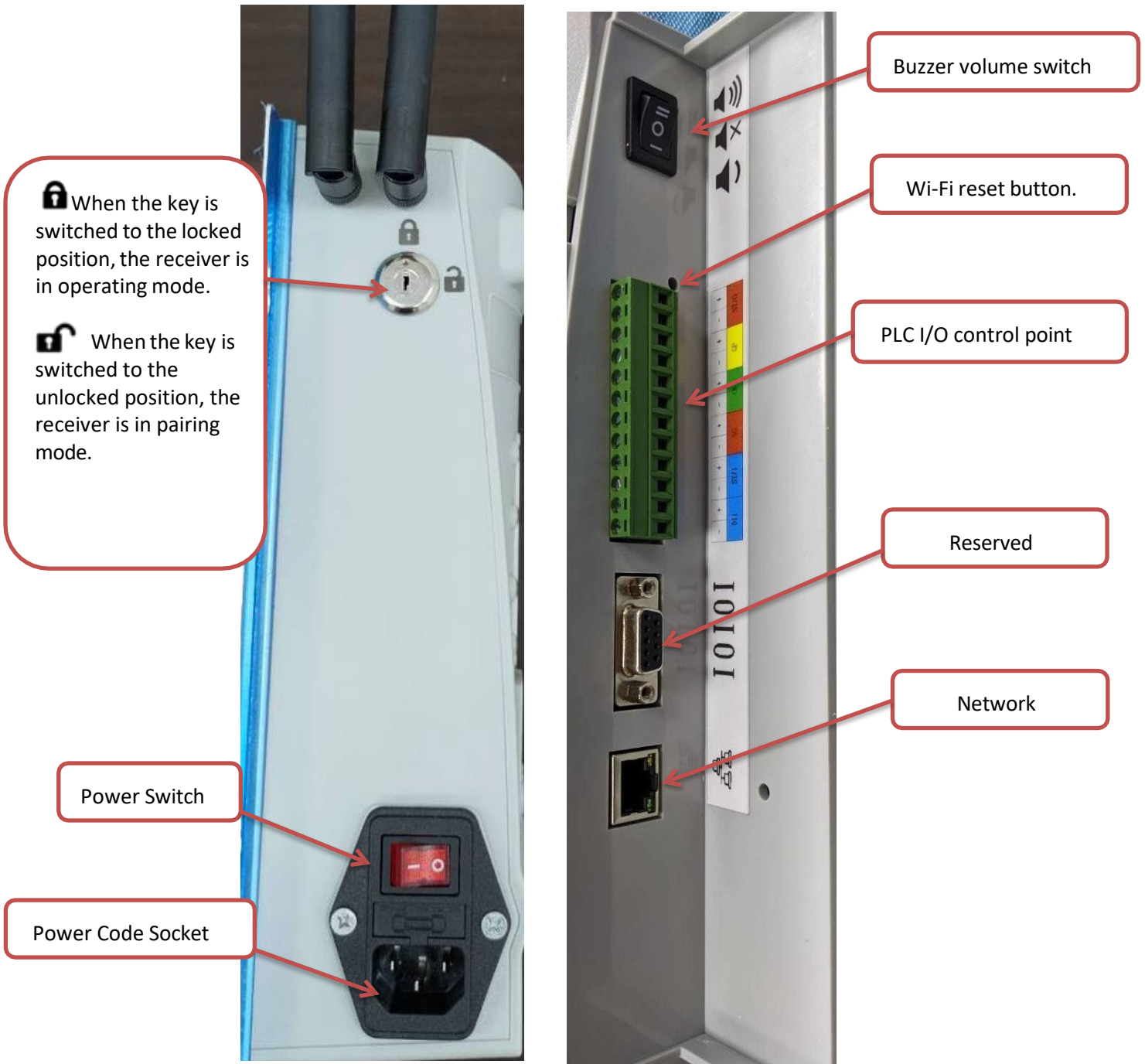

Figure 3 Wiring and Switches of DWL-B receiver

* The pairing mode and operation mode functions will be described in the following sections.

2-1. Definition and Connection Method of Input/Output (I/O) for PLC

PLC's input/output (I/O) requires an external power supply, and the contacts only provide corresponding functional signal control. Table 1 and Figure 4 show the definition and connection method of the contacts, and the operation corresponds to the tool number displayed on the LCD screen. For example, when "Tool 1" is displayed on the LCD screen, the PLC's I/O will comply with the control signals according to the working condition of "Tool 1". At this time, "Tool 2 to 7" will be disabled.

[Table 1 Definition of PLC contacts]

ST/O	Emergency stop for all of the external operation; the ST/O will be activated
GR	When tool completes the batch count, the GR contact will be activated
OK	When tool completes the target value, the OK contact will be activated
NG	When tool fails to complete the target value, the NG contact will be activated
ST/I	Input for emergency stop
DI1	Input for batch count reset and unlock tool (see remark 1)

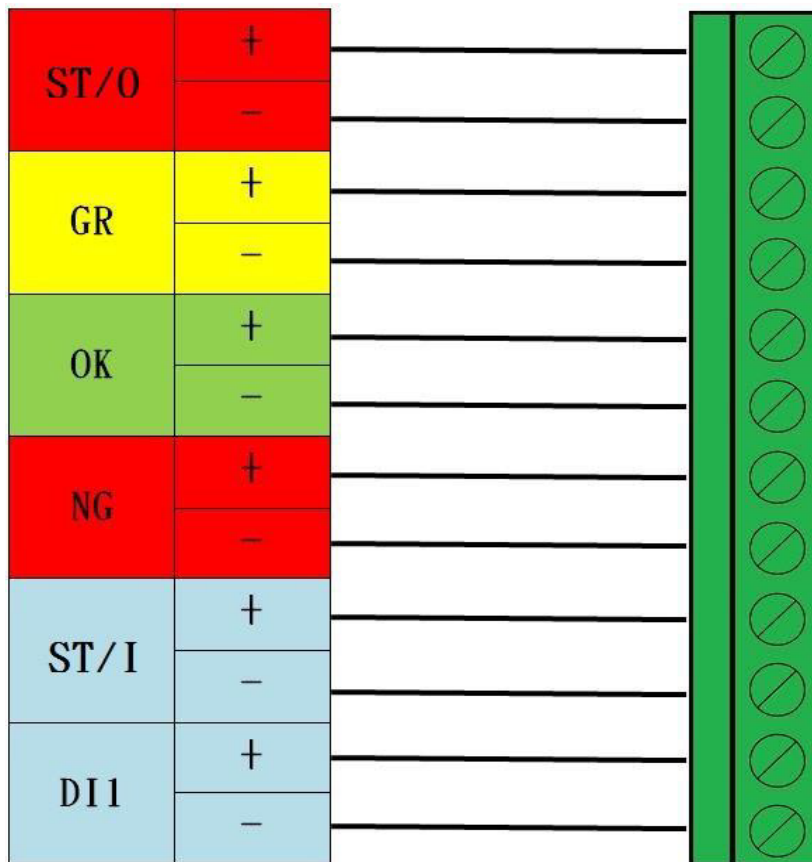

※When connecting to a PLC, it is important to pay attention to the voltage and polarity (+/-) of the connection

Figure 4 The connection of DWL-B receiver and PLC interface

** When 24V DC voltage is input to the "+" terminal of the ST/I contact and 0V is input to the "-" terminal, the emergency stop action will be triggered. At this time, all tools paired with this DWL-B will be locked, and the ST/O contact will be turned on.

** DI1 is the signal input terminal. When the tool completes the batch count, the tool will be locked. To reset the batch count and unlock the tool, input 24V DC to "+" and 0V to "-"
This terminal is currently unavailable for INPA and INRA series tools.

3. LED Indicator Light

The description of the LED signals on the DWL-B receiver are shown in Table 2

Yellow	When the indicator light is on, DWL-B is in the power-on state
Red/Blue Communication Light	<p>A. In pairing mode: The red-light flashes when pairing is unsuccessful, and the blue light stays on when pairing is successful.</p> <p>B. In normal operation mode: The stay-on red light means that the tool is not paired, and the stay-on blue light with red flashing indicates that the tool is already paired and in communication.</p>
Green Indicator Light	<p>A. In pairing mode: When a green and red-light flash, the pairing is unsuccessful. When the pairing is successfully established, the green light will stay on.</p> <p>B. In normal operation mode: When the tighten job is completed, the green light is ON. (see Note 1)</p>
Red Indicator Light	<p>A. In pairing mode: When a green and red-light flash, the pairing is unsuccessful. The red light will turn off when the pairing is successful.</p> <p>B. In normal operation mode: The red light turns on when the tool is unable to complete the job. (see Note 1)</p>
LCD Display	<p>Shows the present tool number or the tool number to be paired.</p> <p>A. In pairing mode: The LCD display flashes when pairing.</p> <p>B. In normal operation mode: LCD display stay on</p>

[Table 2]

Note 1: When operating in standard mode, the DWL-B receiver will show the corresponding light for the tool number displayed on the LCD screen. Depending on the tightening result, the receiver will give a red or green LED light to indicate to the operator whether or not the tool is operating in compliance with the operation standard.

4. LCD Display Operation

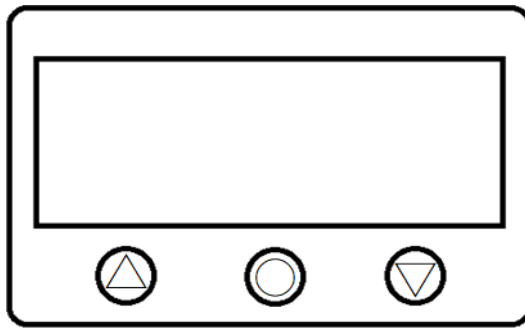
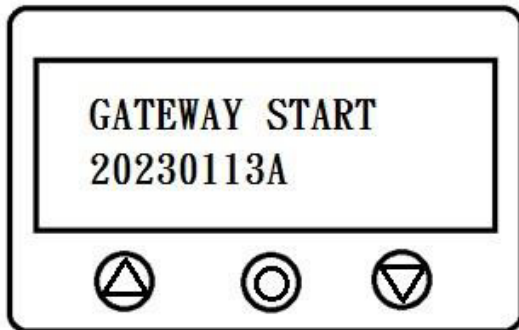

Figure 5

To access the setting mode, turn the key to “unlock” and use the three buttons on the display (see Fig. 5) to select the setting.

A. LCD Display and Pairing Mode – Tool and DWL-B

- I. After turning on the power, the current software version will show on the display (i.e., 20230113A), LINK WAITING for about 30 seconds.



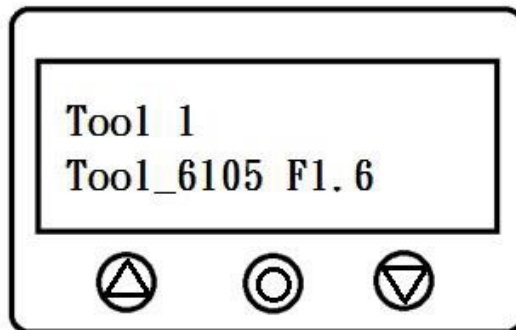
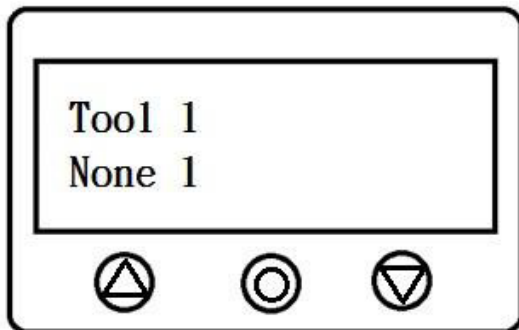

- II. Pairing Display



Non-Pairing

Pairing

III. Pairing Method

Turn the key from “lock” to “unlock”  →  . The screen will flash, indicating pairing mode. Press the middle button briefly (o), then the receiver will start searching for compatible devices to pair with

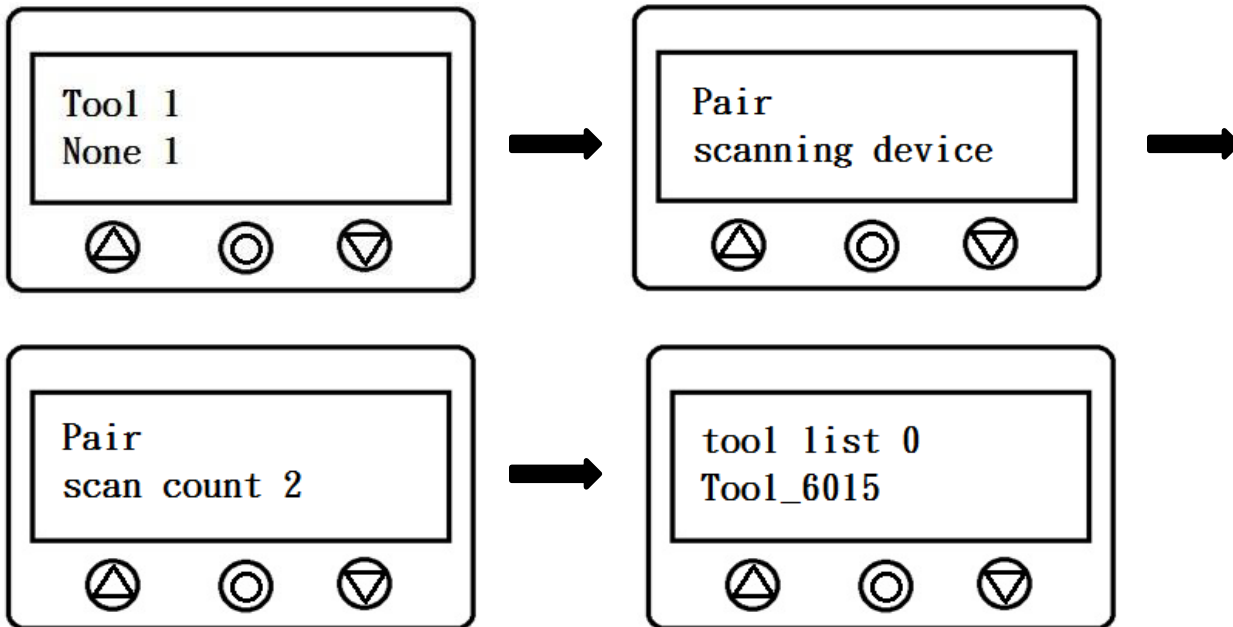

Scan count shows the total number of compatible tools found

The tool number will appear once pairing is successful.

The screen will show the tool identification number after locating a compatible tool. If the tool number on the screen is not the one you want to pair with, press the right button (▽) briefly to select the next tool that has been located.

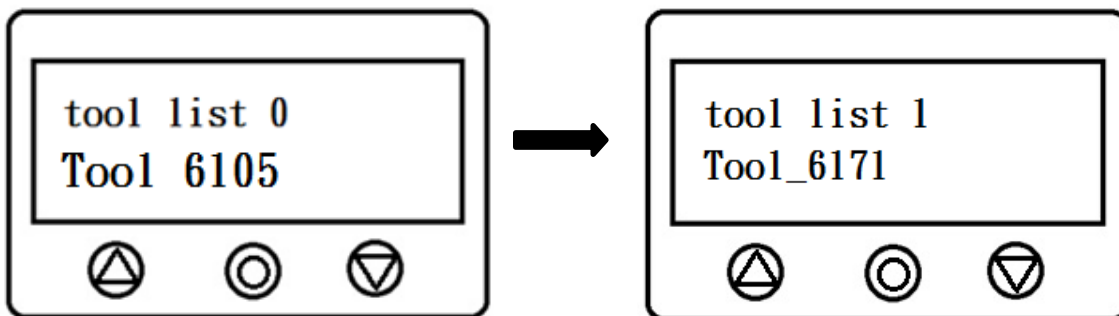

Briefly press (Δ) to search again for compatible tools. The screen will return to the searching mode.
Select and confirm the tool that you would like to pair and press the middle button (O) to start the pairing.

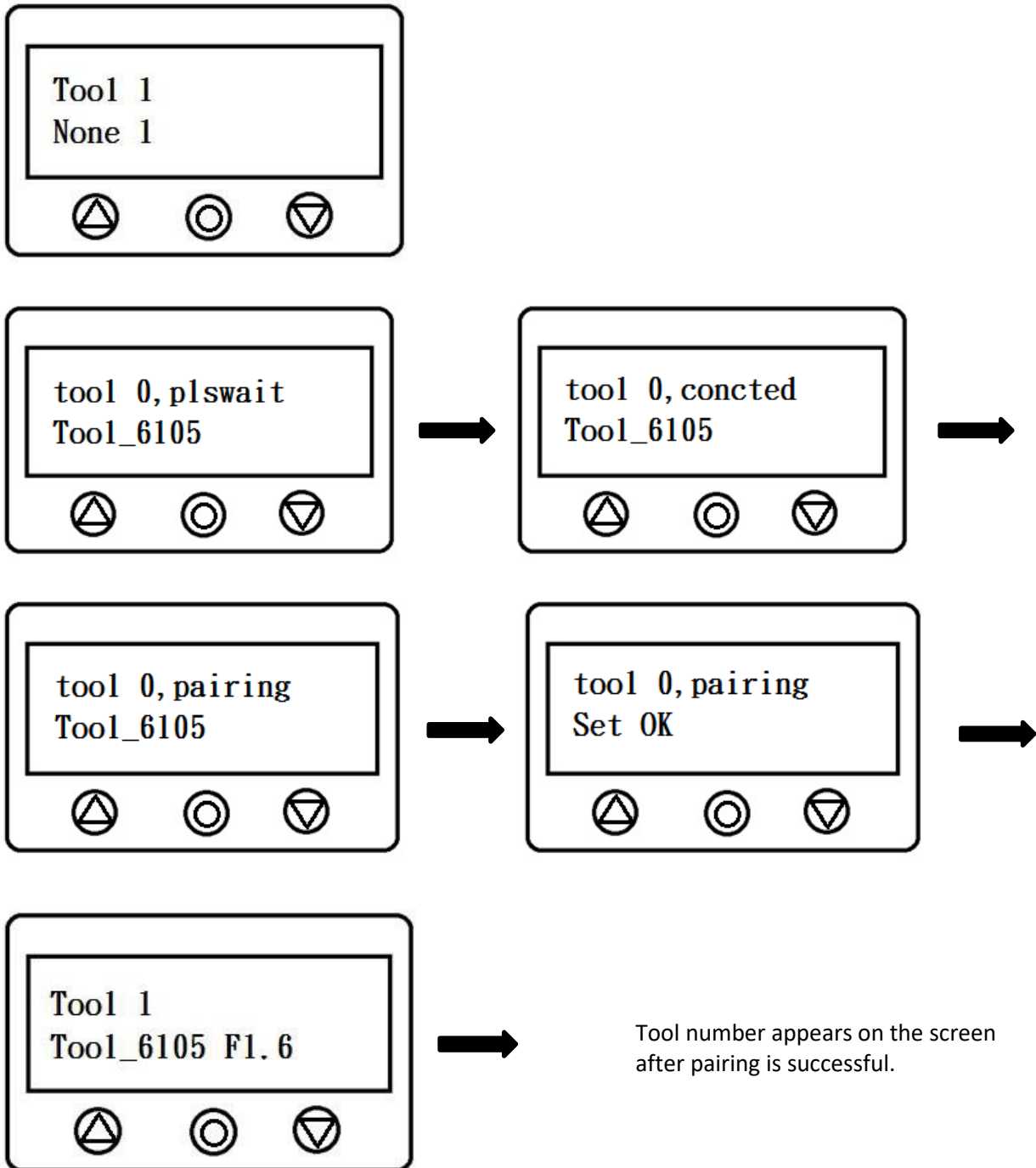

Once successfully paired, switch the key from “unlock” back to “lock.” The tool is now ready for operation.

To remove a paired tool, select the tool to be removed and press the middle button (○) briefly. The receiver will then remove the paired tool and allow for re-pairing.

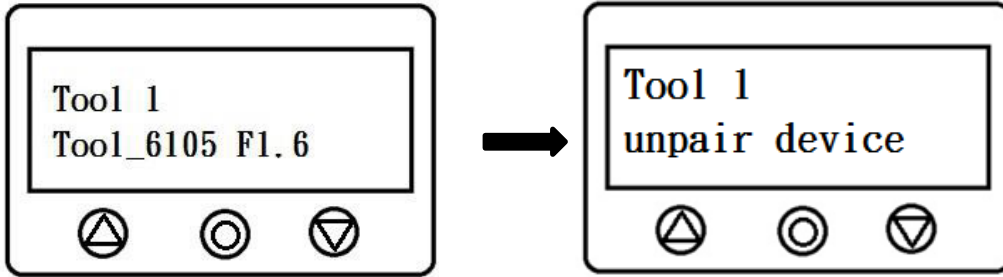

B. Socket selector tray (this feature is enabled only with a paired tool)

After pairing a tool, press the left (△) button in the tool section. The screen will switch to “Screw 1.” If there is no paired socket selector tray, the light will flash. Briefly press the middle button (○) and the receiver will start searching the compatible socket selector tray.

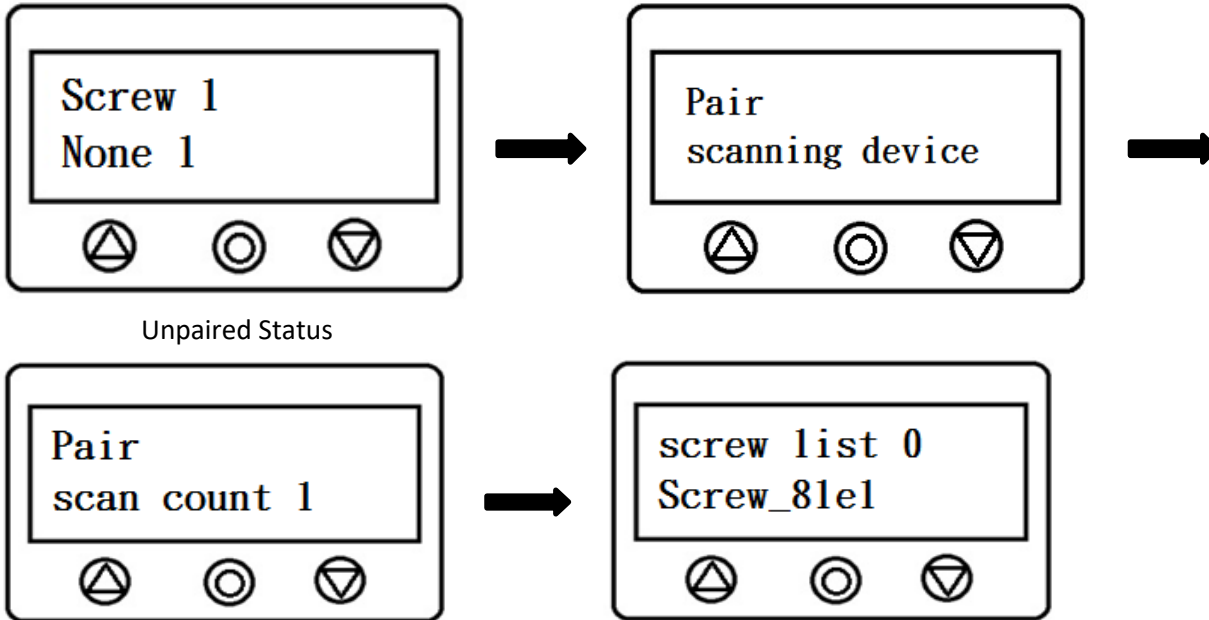

The socket selector tray number will be shown on the screen once the search is complete.

The screen will show the socket selector tray number that is ready for pairing. If the socket selector tray is not the one you want to pair with, press the right button (▽) briefly to select the next socket selector tray.

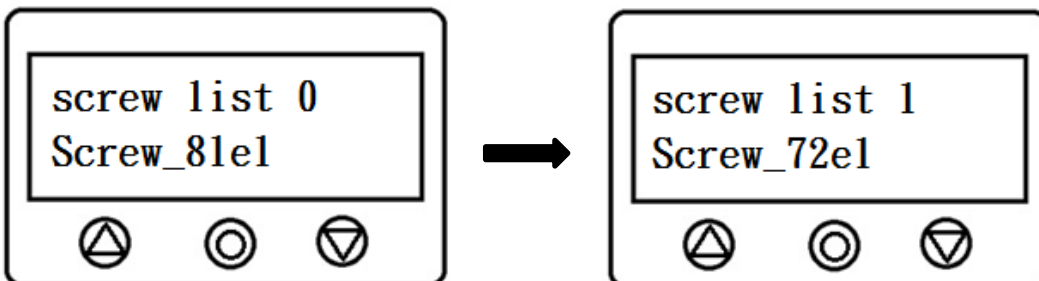

If you would like to re-search the socket selector tray, press the left button (\triangle) to return to the searching mode.

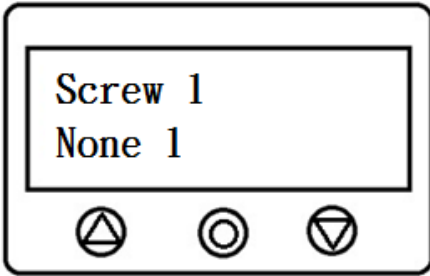

Once the socket selector tray has been selected and confirmed, press the middle button (o) to start the pairing.

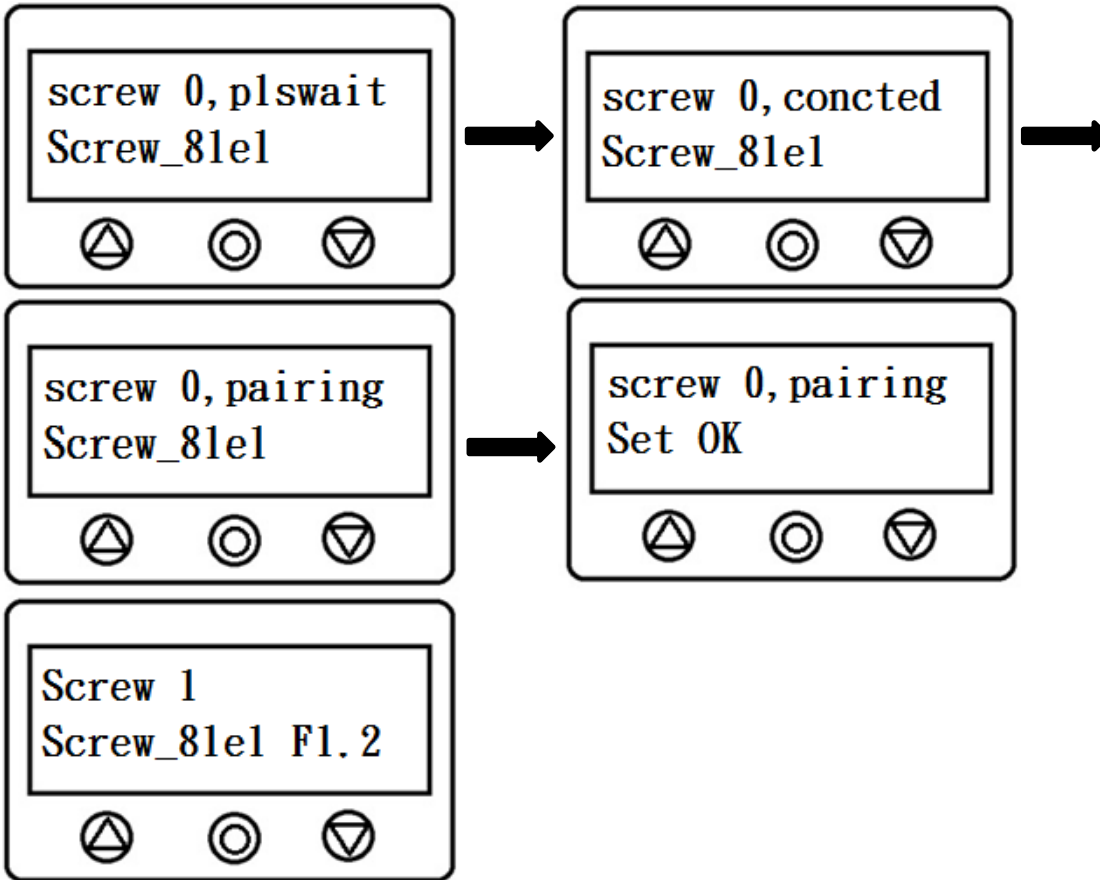

The socket selector tray number will be shown on the display upon pairing.

To remove a paired tool, select the socket selector tray that needs to be removed and press the middle button (o) briefly. The receiver will then remove the paired socket selector tray and allow for re-pairing.

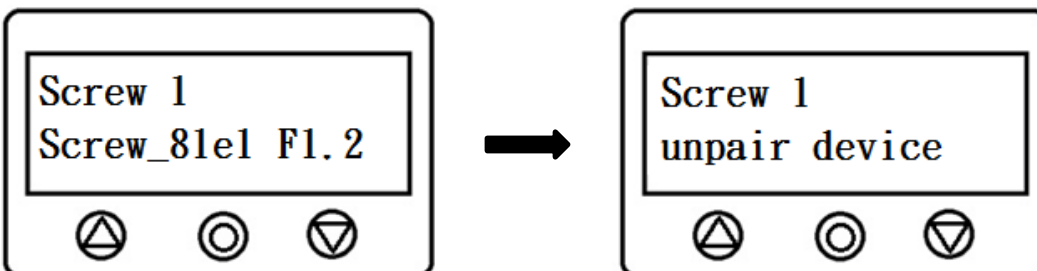

C . Barcode Scanner (this feature is enabled only with a paired tool)

After pairing a tool, press the left (\triangle) button in the tool section. The screen will switch to "Screw 1." Press the left (\triangle) button again and the screen will then switch to Barcode 1. If there is no paired barcode scanner, the light will flash. Briefly press the middle button (\circ) and the receiver will start searching for a compatible barcode scanner.

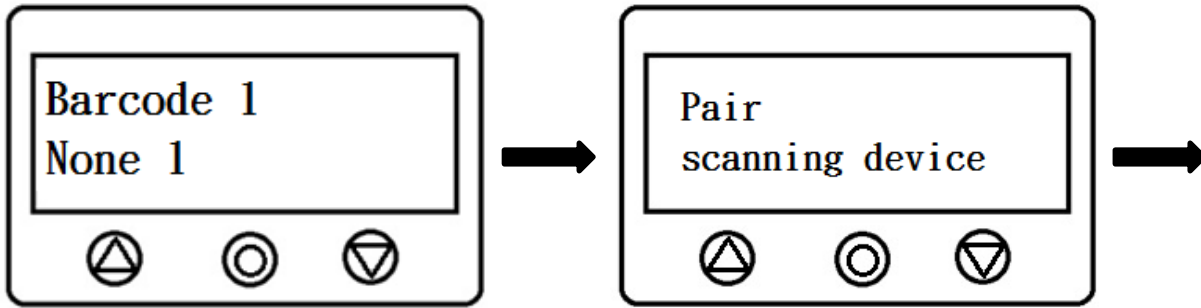

Unpaired Status

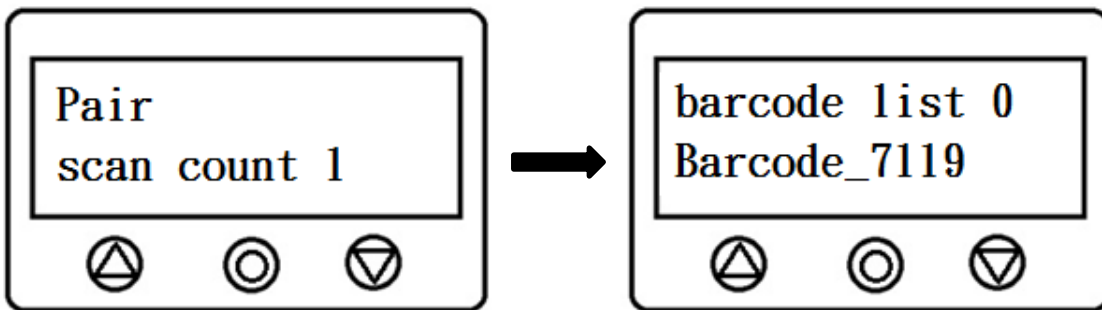

Barcode scanner ID will be shown after searching.

The screen will show the barcode number that is ready for pairing. If the barcode scanner is not the one you want to pair with, press the right button (∇) briefly to select the next barcode scanner.

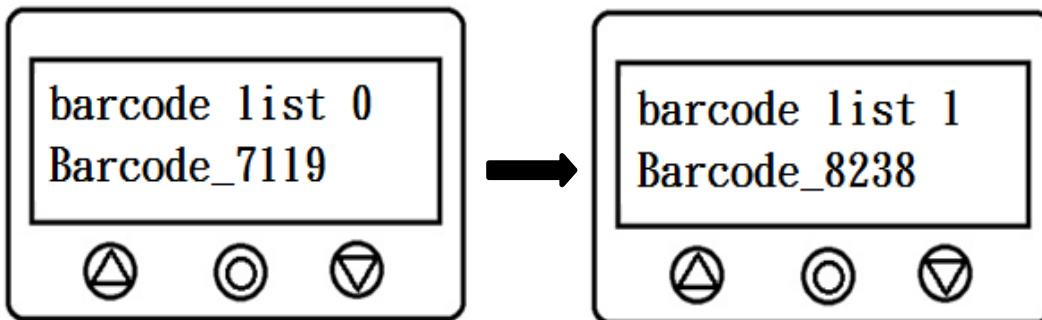

If you would like to re-search for barcode scanners, press the left button (\triangle) to return to the searching mode.

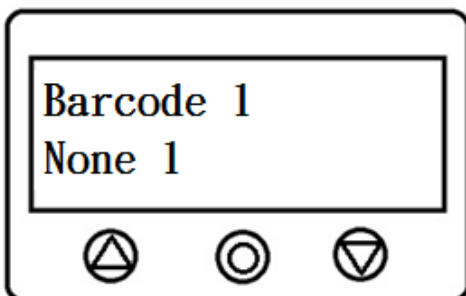

Once the barcode scanner is selected and confirmed, press the middle button (o) to start the pairing.

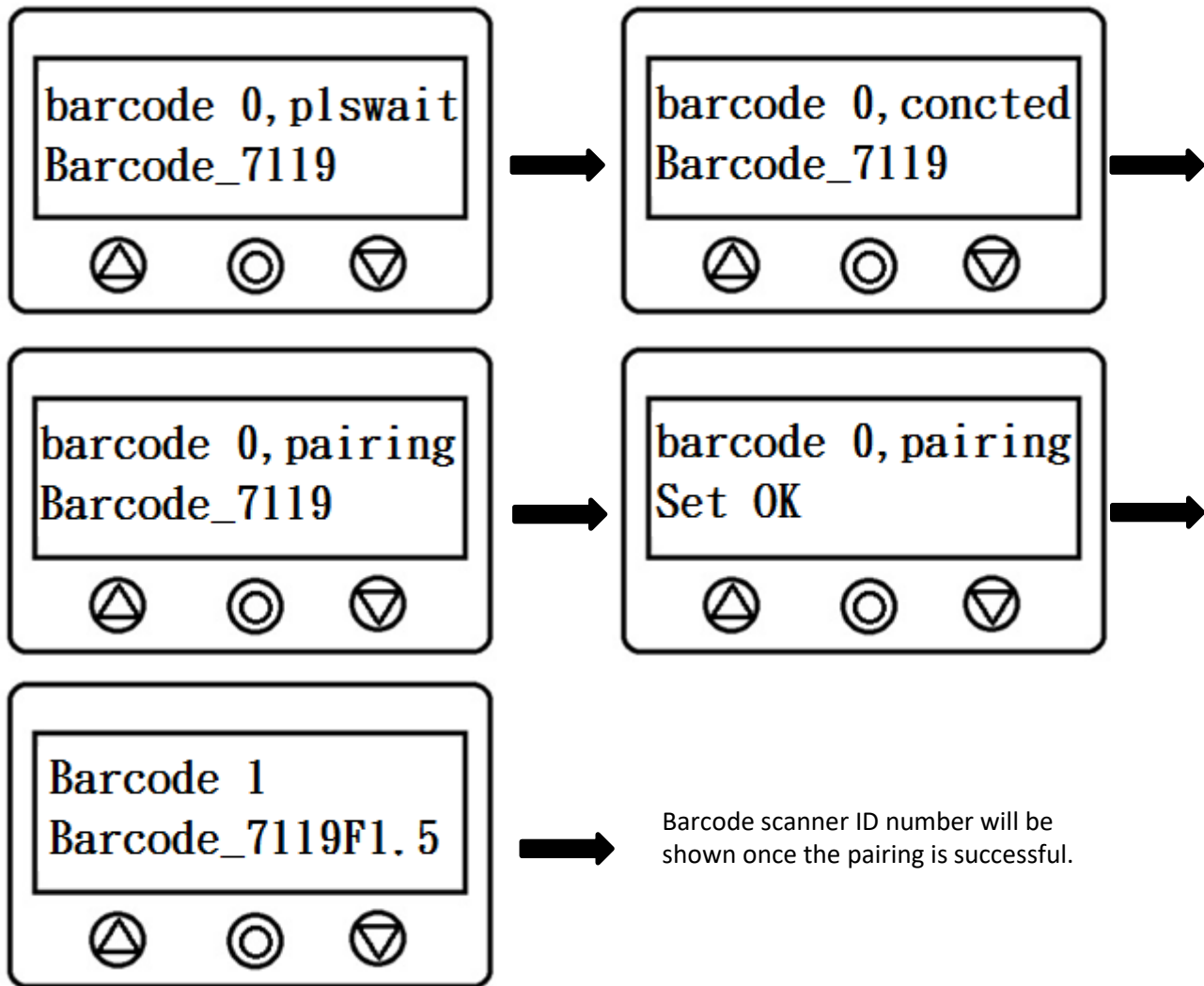

Once successfully paired, switch the key from “unlock” back to “lock.” The tool is now ready for operation.

5. Electrical Specifications

Input Voltage: AC100~240V 0.35A 50/60Hz

Wireless Transmission:

Wi-Fi Module 2.4GHz (802.11 b/g/n)

Wi-Fi Module 5.8GHz (802.11 a/ac/b/g/n)



CORPORATE HEADQUARTERS
10000 SE Pine Street
Portland, Oregon 97216
Phone: (503) 254-6600
Toll Free: 1-800-852-1368
www.aimco-global.com

AIMCO CORPORATION DE MEXICO SA DE CV
Ave. Cristobal Colon 14529
Chihuahua, Chihuahua. 31125
Mexico
Phone: (01-614) 380-1010
Fax: (01-614) 380-1019

LIT-MAN261 Rev. 08-19-2024
©2024 AIMCO