



AB-CTA, AB-MTA, & AB-MCA CORDLESS TOOL OPERATING INSTRUCTIONS



ABP Model

ABS Model

ABN Model

ABT Model



10000 SE Pine St., Portland, Oregon 97216

Phone: (503) 254-6600, 1-800-852-1368

www.aimco-global.com

TABLE OF CONTENTS

1. IMPORTANT INFORMATION	6
<hr/>	
2. GENERAL INFORMATION	6
<hr/>	
2.1.0. Importance of the operating instructions	6
2.2.0. Proper intended use.	6
2.3.0. Improper use	7
2.4.0. Guarantee and liability	7
3. BASIC SAFETY INSTRUCTIONS	9
<hr/>	
3.1.0. Notices in the operating instructions	9
3.2.0. Operator's responsibility	9
3.2.1. Personnel's responsibility	9
3.2.2. Personnel training	9
3.3.0. Risks when working with the tool	9
3.4.0. Danger from electrical energy	10
3.4.1. Fundamental safety measures	10
3.4.1. Workplace safety	10
3.4.2. Electrical safety	10
3.4.3. Personal safety	11
3.4.4. Using and handling the power tool	11
3.4.5. Service	12
3.5.0. Lithium-ion battery	12
3.6.0. Cleaning and disposing of the tool	14
3.7.0. Risk of injury and damage to the tool	14
4. START-UP	15
<hr/>	
4.1.0. Installing or removing the battery	15
4.1.1. Trigger	15
4.1.2. Rotating direction switch.	16
4.1.3. LED / Barcode scanner	16
4.1.4. Multi-color LED control light	17
4.2.0. Setting the tightening torque.	18
4.3.0. Cancel job	18
4.4.0. Back-up strategy	19
4.5.0. Operation	21
5. DISPLAY	22
<hr/>	
5.1.0. Status Displays	23
6. ACCESSORIES	29
<hr/>	
7. TECHNICAL DATA	30
<hr/>	
7.1.0. CTA Model Specifications	30
7.2.0. MTA Model Specifications	32
7.3.0. MCA Model Specifications	34

Disposal

Power tools, batteries, accessories and packaging must be disposed of at an environmentally-compatible recycling facility. Power tools and batteries do not go into the household trash.



Transport

Li-Ion batteries are subject to specifications in the laws pertaining to hazardous goods. The batteries can be transported on roads by the user without further constraints.

When shipping with third parties (e.g.: freight forwarders), special requirements must be observed for packaging and labeling.

Only ship batteries if the casing is not damaged. Cover the contacts with tape and package the battery so it cannot move around in the packaging. Please comply with other national and international requirements.



NOTICE

This warning symbol indicates additional information that will make your work easier.



WARNING

General warning to prevent operating errors and failures.



DANGER

This indicates a direct hazard for the worker or the tool. This warning symbol is especially important and must be observed.

Pistol Tool Features

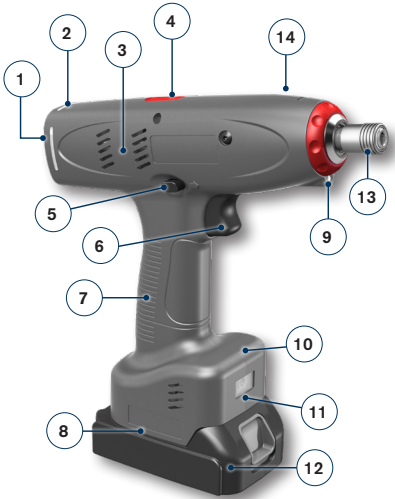

- 1** OLED Display
- 2** Multi-color LED control light
- 3** Brushless high-powered motor
- 4** Color index
- 5** CW / CCW switch
- 6** Large trigger
- 7** Ergonomical handle
- 8** USB interface (in battery compartment)
- 9** Powerful LED
- 10** Optional WiFi module

Straight and Angle Tool Features

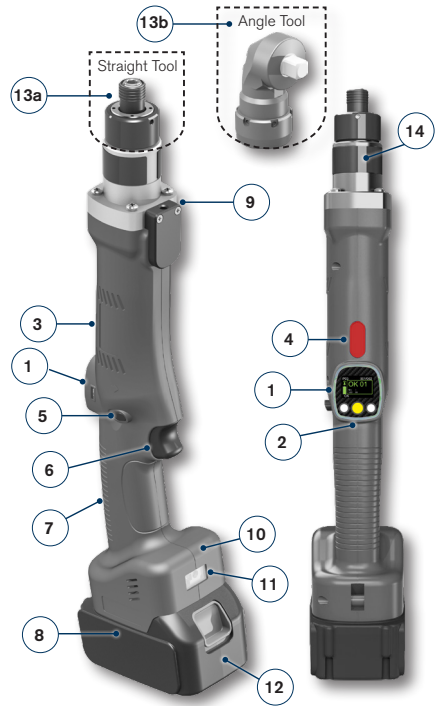

- 11** Optional scanner
- 12** Premium Li-Ion battery
- 13** 1/4" hex socket adapter (Pistol Tool)
- 13a** 1/4" hex socket adapter (Straight Tool)
- 13b** 3/8" square adapter (Angle Tool)
- 14** Clutch Access (MTA & MCA models)





Tool configuration determines which functions can be used. Furthermore each basic function has many subfunctions.

FEATURE	MTA MODEL	CTA MODEL	MCA MODEL
Clutch Shut-Off Tool that Measures Torque and Reports Angle	✓		
Transducer Shut-Off Tool that Controls Torque and Angle		✓	
Clutch Shut-Off Tool that Monitors Torque as Determined by Current and Reports Angle			✓
Five Programmable Configurations with only one tool: <ul style="list-style-type: none"> • Torque • Angle • RPM • Time • Fastening Directions 	✓	✓	✓
Six step, 100 job functionality	✓	✓	✓
Free Software	✓	✓	✓
Interchangeable Battery, USB, Charger	✓	✓	✓
Brushless Motor	✓	✓	✓
Maintenance Indicators	✓	✓	✓
100 Parameter Sets	✓	✓	✓
Operator Feedback and Battery Status on LED display module	✓	✓	✓
Large Storage Capacity – 150,000 data results w/curves on the tool	✓	✓	✓
Can run with iBC ACE Controller	✓	✓	✓
Tactile Feedback	✓	✓	✓
Barcode Scanner	✓	✓	✓
Tool Programming Software loadable through USB cable interface	✓	✓	✓
Long lasting Lithium-Ion Battery	✓	✓	✓
Wireless Communication	✓	✓	✓
Ergonomic	✓	✓	✓

1. IMPORTANT INFORMATION



Before you put the tool down, wait until it has come to a complete stop; otherwise, the tool can jam and you may lose control of the tool.



When tightening and loosening fasteners, high reaction torques can occur. Therefore, always keep a tight grip on the tool.



Switch the electrical device off immediately if the tool used locks up and be prepared for high reaction torques that can cause kickback. The tool locks up when it is overloaded or jams in the workpiece.

2. GENERAL INFORMATION

2.1.0. IMPORTANCE OF THE OPERATING INSTRUCTIONS

This information was written with the intention of being read, understood and complied with in all points by persons responsible for the operation of the AIMCO tool.

Prior to start-up, please read the operating instructions and comply with the safety instructions. Work station faults can only be prevented if the contents of these operating instructions are known and fault-free operation can be ensured.

We are not liable for damages and operational errors that result from non-compliance with these operating instructions. If difficulties arise, please contact us and we will gladly provide assistance.

2.2.0. PROPER INTENDED USE

The tool may only be used, as described in these instructions, to create fastener joints suitable for the type of tool.



Proper intended use also includes:

- complying with all of the the operating instructions
- complying with inspection and maintenance work.

Any other use beyond this is not considered proper intended use. AIMCO is **not** liable for any damages resulting from non-compliance.

2.3.0. IMPROPER USE

AIMCO is not liable for damages and operational errors that result from non-compliance with these operating instructions or improper use.



The tool is not a torque wrench. This tool cannot be used for already tightened connections because very high reaction torques can cause the motor control and the motor to overheat.

2.4.0. GUARANTEE AND LIABILITY

NEW TOOL AND ACCESSORY WARRANTY

Any new tool or accessory branded with the AIMCO, Uryu, AcraDyne or Eagle Industries name, and purchased from AIMCO, or through one of its authorized distributors or agents, is warranted to the original buyer against defects in materials and workmanship for a period of one (1) year* from date of delivery. Under the terms of this warranty, AIMCO will repair or replace any product or accessory warranted hereunder and returned freight prepaid proving to AIMCO's satisfaction to be defective as a result of workmanship or materials. In order to qualify for this warranty, written notice to AIMCO must be given immediately upon discovery of such defect, at which time AIMCO will issue an authorization to return the tool. The defective item must be promptly returned to an authorized AIMCO service center with all freight charges prepaid.

REPAIRED TOOL WARRANTY

Once a tool is beyond the new product warranty period as detailed above, AIMCO repairs are subject to the following warranty periods: pneumatic tools: 90 days*; electric tools and Acra-Feed: 90 days; battery tools: 30 days*; DC Electric tools: 90 days*

EXCLUSION FROM WARRANTY

This warranty is valid only on products purchased from AIMCO, or thru its authorized distributors or agents. AIMCO shall have no obligation pursuant to the AIMCO Warranty with respect to any tools or accessories which in AIMCO's sole judgment have been altered, damaged, misused, abused, badly worn, lost or improperly maintained. This Warranty is null and void if the customer, or any other person other than an authorized representative of AIMCO, has made any attempt to service or modify the tool or accessory prior to its return to AIMCO under this Warranty.

The warranty provision with respect to each such product may be amended by AIMCO from time to time in its sole discretion. The liability of AIMCO hereunder shall be limited to replacing or repairing, at its option, any products which are returned freight prepaid to AIMCO and which AIMCO determines to be defective as described above or, at AIMCO's option, refunding the purchase price of such products.

AIMCO reserves the right to make periodic changes in construction or tool design at any time. AIMCO specifically reserves the right to make these changes without incurring any obligation or incorporating such changes or updates in tools or parts previously distributed.

THE AIMCO WARRANTY IS IN LIEU OF ALL OTHER WARRANTIES, EXPRESSED OR IMPLIED, AND AIMCO EXPRESSLY DISCLAIMS ANY WARRANTY OF MERCHANTABILITY OR FITNESS FOR A PARTICULAR PURPOSE. THIS WARRANTY SETS FORTH THE SOLE AND EXCLUSIVE REMEDY IN CONTRACT, TORT, STRICT LIABILITY, OR OTHERWISE.

THIS WARRANTY IS THE ONLY WARRANTY MADE BY AIMCO WITH RESPECT TO THE GOODS DELIVERED HEREUNDER, AND MAY BE MODIFIED OR AMENDED ONLY BY A WRITTEN INSTRUMENT SIGNED BY A DULY AUTHORIZED OFFICER OF AIMCO.

LIMITATION OF LIABILITY

AIMCO'S LIABILITY PURSUANT TO WARRANTY OF THE PRODUCTS COVERED HEREUNDER IS LIMITED TO REFUND OF THE PURCHASE PRICE. IN NO EVENT SHALL AIMCO BE LIABLE FOR COSTS OF PROCUREMENT OF SUBSTITUTE GOODS BY THE BUYER. IN NO EVENT SHALL AIMCO BE LIABLE FOR ANY SPECIAL, CONSEQUENTIAL, INCIDENTAL OR OTHER DAMAGES (INCLUDING WITHOUT LIMITATION, LOSS OF PROFIT) WHETHER OR NOT AIMCO HAS BEEN ADVISED OF THE POSSIBILITY OF SUCH LOSS, HOWEVER CAUSED, WHETHER FOR BREACH OR REPUDIATION OF CONTRACT, BREACH OF WARRANTY, NEGLIGENCE OR OTHERWISE. THIS EXCLUSION ALSO INCLUDES ANY LIABILITY WHICH MAY ARISE OUT OF THIRD PARTY CLAIMS AGAINST BUYER. THE ESSENTIAL PURPOSE OF THIS PROVISION IS TO LIMIT THE POTENTIAL LIABILITY OF AIMCO ARISING OUT OF THIS AGREEMENT AND/OR SALE.

Note: The AIMCO Warranty confers specific legal rights, however some states or jurisdictions may not allow certain exclusions or limitations within this warranty.

* All warranty periods addressed herein are determined using a standard shift, eight-hour work day.

3. BASIC SAFETY INSTRUCTIONS

3.1.0. NOTICES IN THE OPERATING INSTRUCTIONS

- The basic requirement for safe and proper use and fault-free operation is knowledge of the basic safety instructions and safety regulations.
- In addition, the rules and regulations for the place of use must be followed.

3.2.0. OPERATOR'S RESPONSIBILITY

The operator is obligated to only allow persons to work with this tool who are familiar with the basic regulations for work safety and accident prevention and are trained in how to use the tool. Safety-conscious work of the personnel must be checked at regular intervals.

3.2.1. PERSONNEL'S RESPONSIBILITY

All persons working with this tool are obligated to comply with the basic regulations for work safety and accident prevention prior to starting work.

3.2.2. PERSONNEL TRAINING

Only trained and qualified personnel may work with this tool. The responsibilities of the personnel for the assembly, start-up, operation, maintenance, and servicing must be clearly defined. Personnel-in-training may only operate the tool in the presence of an experienced person.

3.3.0. RISKS WHEN WORKING WITH THE TOOL

Faults that may hinder safety must be immediately rectified.



The tool was built in accordance with state-of-the-art technology and approved safety regulations. Still, when using it, risks to life and limb of the user or third parties or other material assets may arise.



- Only use the tool
- for the proper intended use
 - in working order with regard to safety

3.4.0. DANGER FROM ELECTRICAL ENERGY



Only allow a qualified electrician to perform work on this tool. The electrical equipment of the tool must be regularly inspected. Loose connections and charred cables must be immediately repaired. If work must be performed with the tool, remove the battery prior to opening the device.



The tool must be kept closed at all times. Access is only permitted for authorized persons with a tool.

3.4.1. FUNDAMENTAL SAFETY MEASURES



The terms "tool" and "power tool" used in the safety instructions pertain to mains-operated power tools (with power cable) and battery operated power tools (without power cord).

3.4.1. WORKPLACE SAFETY

- a) **Keep your workspace clean and well lit.** Disorder or poorly lit workspaces can lead to accidents.
- b) **Do not use the tool in an explosive environment,** in which flammable liquids, gases or dusts are located. Power tools can generate sparks which can ignite the dust or vapors.
- c) **Take environmental influences into account.** Never subject tools to rain. Do not use in moist or wet environments.
- d) **Keep other persons away from tool while in use.** If you are distracted, you can lose control of the device.

3.4.2. ELECTRICAL SAFETY

- a) **Avoid physical contact with grounded surfaces such as pipes, heaters, etc.** There is an increased risk of electrical shock if your body is grounded.

- b) **Keep the device away from rain or moisture.** Water penetrating into the tool increases the risk of electrical shock.
- c) **Keep tool away from heat, oil, sharp edges, or moving device parts.**

3.4.3. PERSONAL SAFETY

- a) **Be careful, pay attention to what you are doing, and use power tools responsibly.** Do not use power tools when you are tired or under the influence of drugs, alcohol, or medication. One moment of carelessness when using the tool can lead to severe injuries.
- b) **Always wear personal safety equipment and protective eyewear.** Wearing protective safety equipment such as a dust mask, safety shoes, a protective helmet, and hearing protection, depending on the type and use of the tool, decreases the risk of injuries.
- c) **Avoid unintended start-up.** Ensure that the power tool is shut off before you connect it to the battery, pick it up, or carry it. If you have your finger on the trigger while carrying the power tool, or the device is connected to the power supply, this can lead to accidents.
- d) **Avoid non-ergonomic posture.** Make sure you are standing stably and always maintain your balance. You can then control the power tool in unexpected situations.
- e) **Wear suitable clothing.** Do not wear loose clothing or jewelry. Keep your hair, clothing and gloves away from moving parts. Loose clothing, jewelry, or long hair can get caught in moving parts.

3.4.4. USING AND HANDLING THE POWER TOOL

- a) **Do not overload the tool.** Use the proper tool for your work. You work better and more safely in the defined output range when using the proper tool.
- b) **Do not use power tools with defective switches.** A tool that cannot be shut off is dangerous and must be repaired.
- c) **Remove the battery before you change tool settings, replace accessories, or lay the tool down.** This prevents the power tool from starting unintentionally.
- d) **Store unused tools out of reach of children.** Do not allow persons to use the device who are not familiar with it or have not read these instructions. Power tools are dangerous if they are used by inexperienced persons.

- e) **Take good care of the power tool.** Check that moving parts work properly and do not jam, that there are no broken or damaged parts, and that the functionality is not hindered. Have damaged parts repaired prior to using the device. Many accidents are caused by poorly maintained power tools.
- f) **Keep the tools clean.** Carefully maintained tools jam less often and are easier to use.
- g) **Use the tool, accessories, etc. in accordance with these instructions.** Take the working conditions and task to be executed into account. The use of power tools for other purposes than the intended use can lead to hazardous situations.
- h) **Use the right tool.** Do not use low-output tools for heavy loads. Do not use the tool for purposes and work for which it is not intended.
- i) **Check your tool for damage.** Prior to further use of the tool, the safety equipment or damaged parts must be inspected to ensure proper functionality.

Check to ensure the functionality of moving parts, that they don't jam, that no parts are broken, and that all parts are properly and correctly installed and all conditions required for the operation of the device have been fulfilled.

Damaged safety equipment and parts should be properly repaired or replaced by trained and qualified personnel unless otherwise indicated in the operating instructions. Damaged switches must be replaced by trained and qualified personnel. Do not use tools on which the trigger cannot be easily switched on and off.

3.4.5. SERVICE



Only allow your power tool to be repaired by a qualified technician using only original spare parts, available from AIMCO. This ensures that the safety of your device is maintained.

3.5.0. LITHIUM-ION BATTERY



Please make sure to follow the following instructions for using lithium-ion batteries.

- a) **Only charge the batteries in chargers recommended by the manufacturer.** If the battery is not charged on a suitable charger, it can be permanently damaged.
- b) **Only use the provided battery for power tools.** The use of other batteries can lead to injuries and fire hazards.
- c) **If the battery is unused for an extended period of time, it must not remain on the charger or on the tool.** If a work break of more than 3 hours is expected, the battery must be removed from the tool. Otherwise, the battery may be permanently damaged.
- d) **The lithium-ion battery should not remain on the charger for longer than 36 hours for safety reasons.** Remove the battery from the charger immediately after the charging process is completed.
- e) **An empty battery should not be in contact with the tool or a charger that is disconnected from the mains for an extended period of time.** In both cases, currents are flowing that deep discharge the battery and can permanently damage it.
- f) **Recharge the lithium-ion batteries immediately and never store them when empty.** If the battery is stored while disconnected from the tool and the charger, it will maintain a constant capacity over a long period of time. (Loss approx. 5% per year.)
- g) **Always transport the battery separately from the tool.** This prevents the tool from accidentally switching on and deep discharging the battery.
- h) **Do not subject the lithium-ion battery to high temperatures (+ 50° C) or direct sunlight.** If the battery gets warmer than 50° C during operation (charging or discharging), it must be removed from the charger or tool immediately.
- i) **Keep the unused battery away from paper clips, coins, keys, nails, screws or other small metal objects which might bridge the contacts. Do not open the battery and do not short-circuit it.** A short-circuit between the battery contacts can lead to burns, fire, or explosions.
- j) **Under extreme use or temperature conditions, batteries can leak.** Avoid contact with the skin or eyes if the battery leaks. The battery fluid is acidic and can cause chemical burns. If the fluid comes into contact with skin, immediately wash it with soap and water and then rinse it with lemon juice or vinegar. If the fluid gets into the eyes, flush with water for at least 10 minutes and immediately go to the doctor.
- k) **Make sure that the Li-Ion battery does not fall down or is subject to vibration and impact.**
- l) **Clean the contacts regularly with a cotton swab soaked in a high-percent alcohol.**



Lithium-ion batteries have nearly no self-discharge and do not have a memory effect. If properly used, they will reliably supply your tool with power for several years (approx. 700 - 1000 charge cycles).

In general, avoid deep discharging or overcharging the lithium-ion battery under any circumstances. It will be permanently damaged from this.

3.6.0. CLEANING AND DISPOSING OF THE TOOL

Use and dispose of used materials and substances properly, in particular cleaning agents and solvents.

Do not throw the used battery in the household trash, a fire, or in water. Have it properly disposed of by a specialist shop or the manufacturer.

3.7.0. RISK OF INJURY AND DAMAGE TO THE TOOL

1. Make sure that none of the tool parts are damaged. All damaged parts must be repaired prior to using the device. If you work with damaged tool parts, you risk injury.
2. If you work on raised platforms, wear a safety belt and avoid letting the tool fall down. Non-compliance may lead to injury and significant damage.
3. First remove the battery before you clean the device or perform general maintenance.
4. Never hold your face near the exhaust holes.
5. Avoid skin contact with substances such as lubricating grease and oil. These substances are flammable on skin. If you do come into contact with them, thoroughly wash the area.
6. Avoid unstable working positions. You might fall and injure yourself.
7. Maintain your tool carefully. Follow the operating instructions for maintenance and cleaning.
 - Keep the handle free of lubrication greases and dirt.
8. Use the tool carefully and pay attention to proper use. Always concentrate while working.

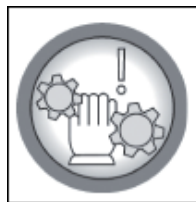

4. START-UP

Do not let the tool fall or allow other objects to fall on the device. Protect it from impact damage. Make sure that the device does not come into contact with sprayed water or oil.

4.1.0. INSTALLING OR REMOVING THE BATTERY

- To remove the battery, set the rotational direction switch to the center position, slide the clip on the front side of the battery back, and pull it forward away from the tool.
- To install the battery, align the tongue of the battery with the groove in the casing so it can easily slide into place.
- Always slide it on completely until it locks with a click. Check that the battery is correctly locked in place before starting to work.

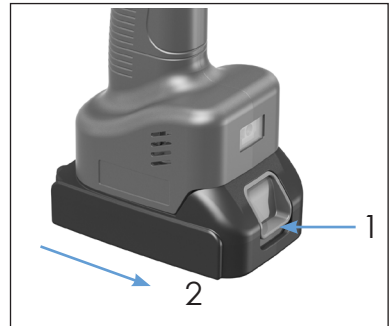

1 – Clip
2 – Remove battery

If the battery is not installed properly, it can fall out of the tool and lead to injuries.

- Never use force when installing the battery. If the battery cannot be easily slide in, it has not been correctly installed.

4.1.1. TRIGGER

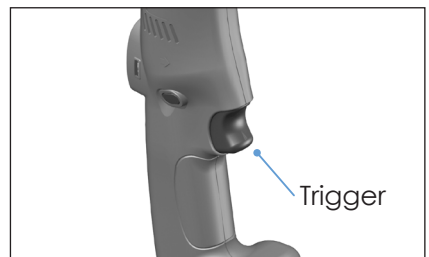
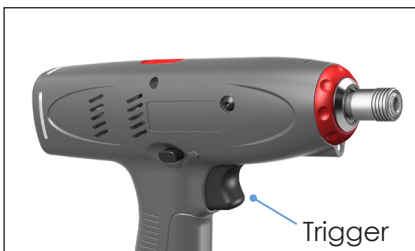

4.1.2. ROTATING DIRECTION SWITCH



Before you remove the battery or install it on the tool, please check that the rotating direction switch is in the neutral position. Always check the rotating direction switch prior to operation.

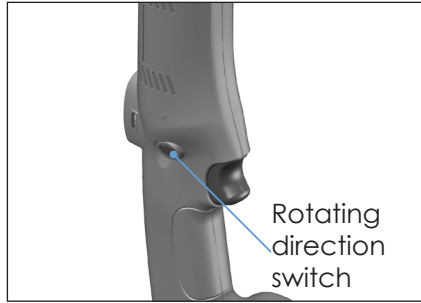
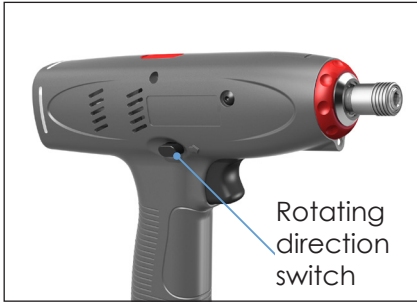

To change the rotating direction, the tool is equipped with a rotating direction switch.

- Only use the rotating direction switch after the tool has come to a complete stop. Changing the rotating direction during operation damages the device.
- If you are not using the tool, set the rotating direction switch to the neutral position.
- To change or set the direction, press the rotating direction switch

out to the left for **clockwise rotation** 

out to the right for **counter-clockwise rotation** 

If the rotating direction switch is set to the center position, the trigger cannot be activated.

4.1.3. LED / BARCODE SCANNER



Never look directly at the LED or barcode scanner!

After pressing the trigger, the LED and the barcode scanner will switch on. The afterrun illumination of the LED after the trigger has been pressed can be defined in the AcraDyne Tool Manager under Settings - General. The released barcode scanner goes off after a barcode is successfully scanned and/or the trigger has been released.



NOTICE

Do not clean the LED with aggressive cleaning agents!



NOTICE

The optional barcode scanner must be activated in the hardware settings of AcraDyne Tool Manager software.

4.1.4. MULTI-COLOR LED CONTROL LIGHT

The AcraDyne cordless series has a LED control function that is near the display and spans the circumference of the tool. The light indicates tool status:

The time-length of the light can be programmed as glowing, flashing, or pulsating for each LED signal.

More information about LED Control Light programming can be found in the AcraDyne Tool Manager manual.



Color Indicator:



Screwdriver is released



Tool is on reverse mode; counter-clockwise rotation



Tightening was successful (OK)



Error at tightening (NOK)



Tool needs acknowledgement of the result or action of the worker

4.2.0. SETTING THE TIGHTENING TORQUE

For the **MTA and MCA Series**, the tightening torque is adjusted with a mechanical clutch.



To adjust the clutch, the protective covering needs to slide open.

- 1) Carefully press down the rear of the covering.
- 2) The clip will easily slide backward.
- 3) The clutch will be visible. Now the clutch can be adjusted with a torque adjustment tool.

- counter-clockwise: lower torque
- clockwise: higher torque



After the adjustment, slide the cover back into its initial position. It will close and lock automatically.

Check the torque with a torque measurement unit. If the requested value isn't reached, adjust the clutch again.

For the **CTA Series**, the tool will be programmed with AcraDyne Tool Manager software. Make sure that the tool is configured and parameterized correctly. See the AcraDyne Tool Manager user manual for operating instructions.



RISK OF INJURY

If a low torque is expected and a very high torque is set unintentionally.

4.3.0. CANCEL JOB



If you want to execute a job later or you have scanned the wrong barcode, you can cancel this after the release.

To do this, hold down the display button for approx. 3 seconds. The cancel symbol will appear. Confirm this by pressing the left side display button.

4.4.0. BACK-UP STRATEGY



To activate the back-up strategy, the "Set-up" menu must be activated in the software under the general settings. Also activate "scanner selectable" so the set-up menu point "Scanner" can be selected. If you also activate "Manual mode selectable," the set-up menu points "M" and "Scanner M" will be released. So you can select different programs per display, the check mark next to "Manual mode active" must also be selected.

If the connection to the controller (process controls) via wireless connection through an access point is interrupted and a job has already been released in the tool, it should be further processed if possible. After completing the job, the tool will try to send the fastening process results. If the connection to the process controls cannot be restored, the fastening process results must be manually secured (read out of the tool using the AcraDyne Tool Manager software and saved).

Then, after removing the battery, the back-up strategy can be used to continue working.

To do this, hold down the trigger and slide the battery back on. After approx. 3 seconds, the set-up symbol will appear on the display. You can now release the trigger and will be in the set-up menu.

By pressing the menu button, you can go to the next menu point. By pressing the trigger, you can select a menu point. Using the left button, confirm your selection; with the right button, cancel the selection.



In the "Scanner M" menu, select the scan mode for scanning barcodes for program selection. Scan the barcodes for the fastening job as in regular mode. You will receive the release for the corresponding program with the number of fasteners.

The fastening results are not transmitted to the process controls for central storage. You can, however, read the fastening process results with AcraDyne Tool Manager software and save them as a file.

Go forward with the menu button until the "Scanner M" logo appears. The tool has to be programmed accordingly with AcraDyne Tool Manager.



Press the trigger to select the setting.



To confirm the back-up strategy with scanning function, press the left button on the display.



In the Info menu, the most current battery voltage, network coverage RSSI, and the version of the firmware can be displayed.

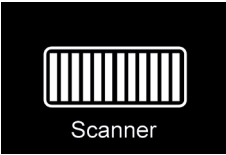

In the Scanner menu, the scanner can be selected to read in network settings using a barcode. Scanning for program selection is not possible in this mode.



In the Program menu, you can select from a list of stored programs.



In the M menu, manual mode can be selected (M = manual mode). This activates the "standard program" (yellow star).



In the Scanner M menu, you can choose to activate a program directly by scanning its barcode. The barcodes and their assignment to a program must be stored in the tool.



By activating the Exit menu, you will exit setup. The tool will switch back into normal mode.

4.5.0. OPERATION



Hold the tool with its tool insert straight against the fastening location with the necessary compression force; otherwise, it may be damaged (cam-out effect).

To ensure the SAFETY and RELIABILITY of the product, repairs, maintenance, and adjustments should be performed by AIMCO or an authorized specialist.

5. DISPLAY

Main display window

The main display window shows the results of the fastening process, warnings, commands, symbols, and texts to make controlling the tool easier. The worker always knows immediately whether the work was correct, which torque range is specified for the next fastener joint, or why the tool is not executing a fastening process. Furthermore, the worker is notified by the integrated battery management system that the battery needs to be changed before it can be damaged due to deep discharging.

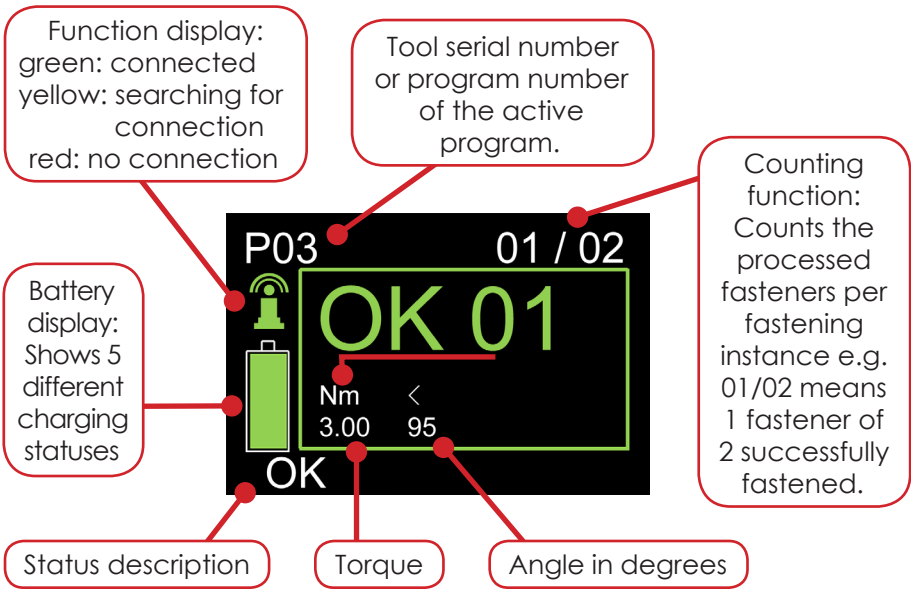

Display elements can be modified in AcraDyne Tool Manager so the worker is shown, for instance, precise values for the fastener joints, rotational angle, only an OK or NOK, or the counting process. You can set in which unit the values are output (Nm, lbf.in, lbf.ft).

5.1.0. STATUS DISPLAYS

Battery Status

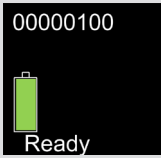

50% - 100%

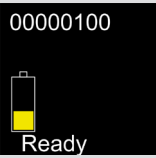

30% - 50%

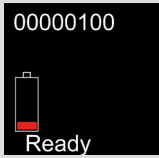

10% - 30%

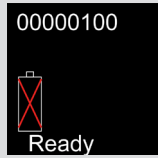

5% - 10%

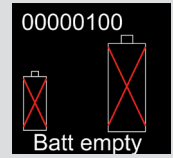

Less than 5%

Network Status

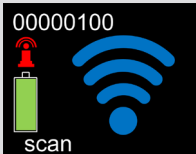

Tool tries to dial into the network.

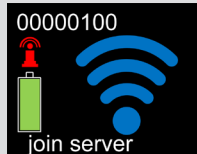

Tool has found the network and connects.



Previously lost connections to the network were restored.



Tool has lost the connection to the network.

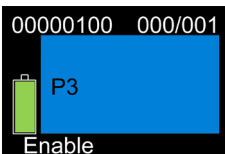

Tool is released for the selected / scanned fastening process. When using the barcode scanner, if there is "NO NUMBER," the corresponding barcode appears on the blue display element as a release.

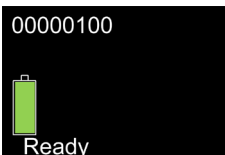

The device is ready to use.

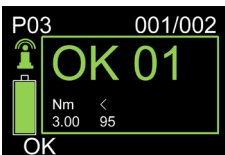

The first of two fastening joints was successful. Second fastening process must still be executed. Results of the first fastening are displayed. This notice is also available as a NOK notice.

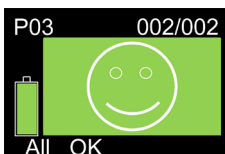

Both of the fastening processes were successful and have reached the specified reference (e.g. Nm) or were in the specified differential range. This notice is also available as a NOK notice.

Status display

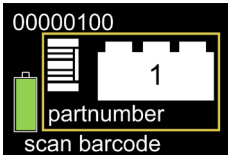

Scanning request:

Component 1, 2 or 3 (depending on the number in the component of the display) has to be scanned before the tool is released.

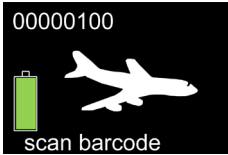

The airplane icon means that a product ID must be scanned before the tool is released. Symbol can also be a car.



Tool is locked and is currently being configured using the AcraDyne Tool Manager via WiFi.

Battery must not be removed.

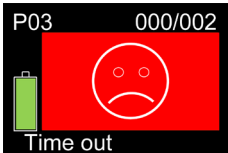

The fastening process for one or more fasteners was not processed within the specified time.

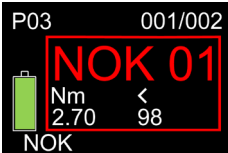

Specifications were not achieved during the fastening process. Values of the fastening joint are displayed.

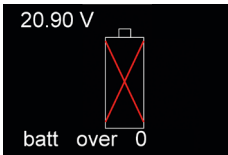

Maximum battery voltage exceeded

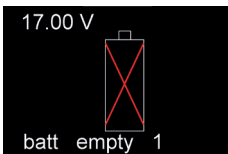

Battery voltage too low



Tool has successfully started up, but cannot connect to the superordinate controls.

Status display



NOK must be separately confirmed by the worker pressing a button on the display.



Tool has received a release for program 3. This will unfasten the fastener with 3.00 Nm.



Tool has received a release for program 3. This will process the fastener with 3.00 Nm.

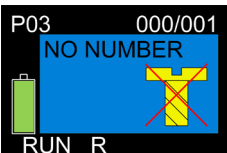

Trigger was released during the fastening process (which is permitted). The fastening process can continue. When using the barcode scanner, if there is "NO NUMBER," the corresponding barcode appears on the blue display element as a release.

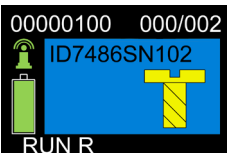

Fastening process is running
When using the barcode scanner, if there is "NO NUMBER", the corresponding barcode appears on the blue display element as a release.

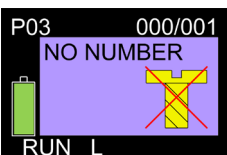

Trigger was released during the unfastening process (which is permitted). The unfastening process can continue. When using the barcode scanner, if there is "NO NUMBER," the corresponding barcode appears on the blue display element as a release.

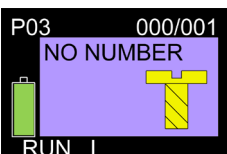

Unfastening process is running
When using the barcode scanner, if there is "NO NUMBER," the corresponding barcode appears on the blue display element as a release.

Status display

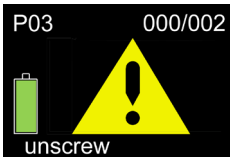

After confirming the NOK ("CONFIRM OK" display), the fastener must be unfastened prior to the next release.



The rotation direction switch is set to counter-clockwise rotation, and unfastening is not allowed. The NOK-screwing in front needs to be acknowledged. This can be programmed in the settings with the AcraDyne Tool Manager.



Battery was installed, tool starts, but cannot connect to the network. Press the trigger to start a new connection.



Current redundancy of the torque was too low.



Current redundancy of the torque was too high.



The fastener must be inspected after a fastening process. A time frame for this can be set (e.g. 15 seconds) and confirmed on the display. The timer runs backward to its reference point. (Graphic stops at 10.9 seconds.) If the fastener is not confirmed within the set time, NOK is automatically selected.



The tool needs to be calibrated and will be released after calibration.



The tool must be serviced and will not be released until after the confirmation from service personnel.

Status display



Maximum fastening time for the released program was exceeded.



Released program is deactivated on this tool.



Released program does not exist on this tool.



Released program sequence does not exist on this tool.

Most common error notifications are illustrated for you here. Since there are several status and error notifications in the electronics area, it is not possible to list them all. If you come across a status or error notification that doesn't make sense, please feel free to contact AIMCO. Many displays can deviate slightly depending on the software settings. For more information, look at your settings and the operating instructions for AcraDyne Tool Manager. If an error occurs several times, please contact the AIMCO support team.

The display elements (status notifications) were created partially with and partially without a Wi-fi connection to a superordinate control system. As soon as the power tool is connected to a control system, the Wi-fi symbol appears over the battery display.

Error displays



Maximum allowable torque exceeded, contact the manufacturer.



Maximum allowable current exceeded, contact the manufacturer.



Temperature of the controls exceeded, contact the manufacturer.

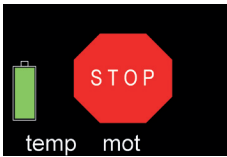

Temperature of the motor exceeded, contact the manufacturer



Maximum logic voltage exceeded, tool must be repaired.



SD card not found in the tool or is defective. If the problem is not solved by inserting a new SD card, please contact the manufacturer.

6. ACCESSORIES

- All tools are delivered with software



Improper use of potential supplemental devices or accessories from other manufacturers may pose a risk (of injury) to persons.



Only use supplemental devices or accessories for the intended purpose. We will gladly assist you if you have questions.

You can request exploded drawings and spare parts list at 1-800-852-1368.

7. TECHNICAL DATA

7.1.0. CTA MODEL SPECIFICATIONS

MODEL	TORQUE RANGE		MAX SPEED RPM	DRIVE TYPE	WEIGHT W/O BATTERY	
	NM	FT-LB			KG	LB
PISTOL						
ABP-CTA12(Q)(WQ)(BQ)(WBQ)	1.5 - 12	1.1 - 8.9	629	1/4" QC	1.15	2.5
ABP-CTA17(Q)(WQ)(BQ)(WBQ)	3 - 17	2.2 - 12.5	449	1/4" QC	1.15	2.5
STRAIGHT						
ABS-CTA12(Q)(WQ)(BQ)(WBQ)	1.5 - 12	1.1 - 8.9	570	1/4" QC	0.95	2.1
ABS-CTA17(Q)(WQ)(BQ)(WBQ)	3 - 17	2.2 - 12.5	460	1/4" QC	0.95	2.1
ANGLE						
ABN-CTA10(W)(B)(WB)	1.5 - 10	1.1 - 7.4	570	3/8" Sq.	1.35	3.0
ABN-CTA17(W)(B)(WB)	2.5 - 17	1.8 - 12.5	380	3/8" Sq.	1.4	3.1
ABN-CTA24(W)(B)(WB)	5 - 24	3.7 - 17.7	300	3/8" Sq.	1.2	2.6
ABN-CTA36(W)(B)(WB)	8 - 36	5.9 - 26.6	170	3/8" Sq.	1.2	2.6
ABN-CTA55(W)(B)(WB)	15 - 55	11.1 - 40.6	90	3/8" Sq.	1.4	3.1
ABN-CTA90(W)(B)(WB)	25 - 90	18.4 - 66.4	60	1/2" Sq.	2.9	6.4
ABN-CTA120(W)(B)(WB)	35 - 120	25.8 - 88.5	50	1/2" Sq.	3.1	6.8
TUBENUT						
ABT-CTA15W	3 - 15	2.2 - 11.1	400	1/4" - 7/16" hex	1.2	2.6
ABT-CTA20W	5 - 20	3.7 - 14.8	300	3/8" - 5/8" hex.	1.2	2.6

W = WiFi option B = Barcode option Q = Quick Change

CTA Model Dimensions

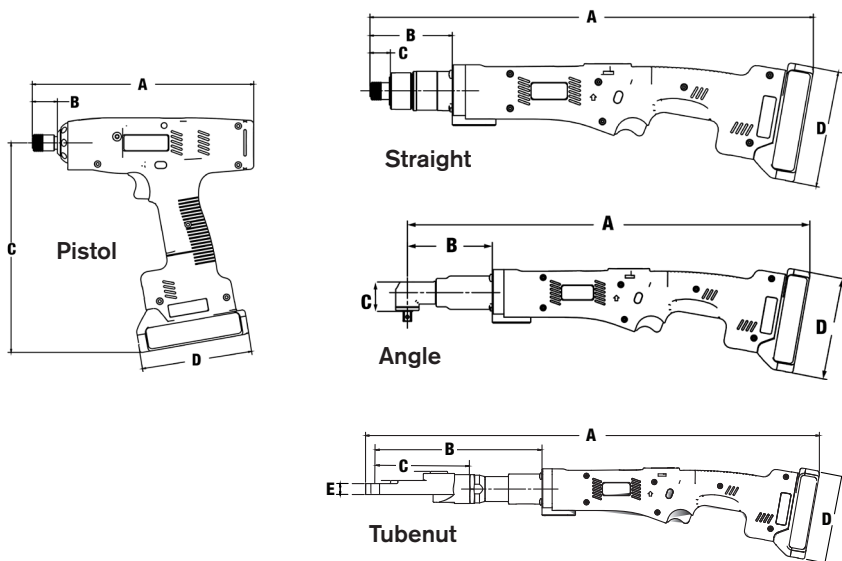

MODEL	TOOL DIMENSIONS									
	A		B		C		D		E	
	IN	MM	IN	MM	IN	MM	IN	MM		
PISTOL										
ABP-CTA12(Q)(WQ)(BQ)(WBQ)	9.1	230	1.02	26	8.56	218	4.5	115	-	-
ABP-CTA17(Q)(WQ)(BQ)(WBQ)	9.1	230	1.02	26	8.56	218	4.5	115	-	-
STRAIGHT										
ABS-CTA12(Q)(WQ)(BQ)(WBQ)	17.2	437	3.19	81	0.79	20	4.5	115	-	-
ABS-CTA17(Q)(WQ)(BQ)(WBQ)	17.2	437	3.19	81	0.79	20	4.5	115	-	-
ANGLE										
ABN-CTA10(W)(B)(WB)	17.9	455	3.94	100	1.12	29	4.5	115	-	-
ABN-CTA17(W)(B)(WB)	18.1	461	4.14	105	1.29	33	4.5	115	-	-
ABN-CTA24(W)(B)(WB)	18.1	461	4.14	105	1.29	33	4.5	115	-	-
ABN-CTA36(W)(B)(WB)	21.6	547	7	179	1.65	42	4.5	115	-	-
ABN-CTA55(W)(B)(WB)	23.1	587	8.61	219	1.65	42	4.5	115	-	-
ABN-CTA90(W)(B)(WB)	25.9	658	11.4	290	1.91	49	4.5	115	-	-
ABN-CTA120(W)(B)(WB)	28.4	720	13.9	352	2.81	71	4.5	115	-	-
TUBENUT										
ABT-CTA15W	22.2	565	7.82	199	4.17	106	4.5	115	0.5	12.7
ABT-CTA20W	22.9	582	8.39	213	4.74	121	4.5	115	0.56	14

W = WiFi option B = Barcode option Q = Quick Change

7.2.0. MTA MODEL SPECIFICATIONS

MODEL	TORQUE RANGE		MAX SPEED RPM	DRIVE TYPE	WEIGHT W/O BATTERY	
	NM	FT-LB			KG	LB
PISTOL						
ABP-MTA06(Q)(WQ)(BQ)(WBQ)	1.0 - 6	0.8 - 4.4	1,100	1/4" QC	1.25	2.75
ABP-MTA08(Q)(WQ)(BQ)(WBQ)	1.5 - 8	1.1 - 5.9	880	1/4" QC	1.25	2.75
ABP-MTA12(Q)(WQ)(BQ)(WBQ)	2.3 - 12	1.7 - 8.9	629	1/4" QC	1.25	2.75
ABP-MTA17(Q)(WQ)(BQ)(WBQ)	3.5 - 17	2.6 - 12.5	449	1/4" QC	1.25	2.75
STRAIGHT						
ABS-MTA06(Q)(WQ)(BQ)(WBQ)	1.0 - 6	0.8 - 4.4	1,100	1/4" QC	1.0	2.2
ABS-MTA08(Q)(WQ)(BQ)(WBQ)	1.5 - 8	1.1 - 5.9	880	1/4" QC	1.0	2.2
ABS-MTA12(Q)(WQ)(BQ)(WBQ)	2.3 - 12	1.7 - 8.9	629	1/4" QC	1.1	2.4
ABS-MTA17(Q)(WQ)(BQ)(WBQ)	3.5 - 17	2.6 - 12.5	449	1/4" QC	1.25	2.75
ANGLE						
ABN-MTA10(W)(B)(WB)	2.5 - 10	1.9 - 7.4	629	3/8" Sq.	1.35	3.0
ABN-MTA17(W)(B)(WB)	3.5 - 17	2.6 - 12.5	420	3/8" Sq.	1.4	3.1
ABN-MTA24(W)(B)(WB)	5 - 24	3.7 - 17.7	300	3/8" Sq.	1.4	3.1
ABN-MTA36(W)(B)(WB)	8 - 36	5.9 - 26.6	165	3/8" Sq.	1.4	3.1
ABN-MTA55(W)(B)(WB)	13 - 55	9.6 - 40.6	94	3/8" Sq.	2.7	6.0
ABN-MTA90(W)(B)(WB)	18 - 90	13.3 - 66.4	70	3/8" Sq.	2.9	6.4
ABN-MTA115(W)(B)(WB)	23 - 115	17 - 84.8	56	1/2" Sq.	3.1	6.8

W = WiFi option B = Barcode option Q = Quick Change

MTA Model Dimensions

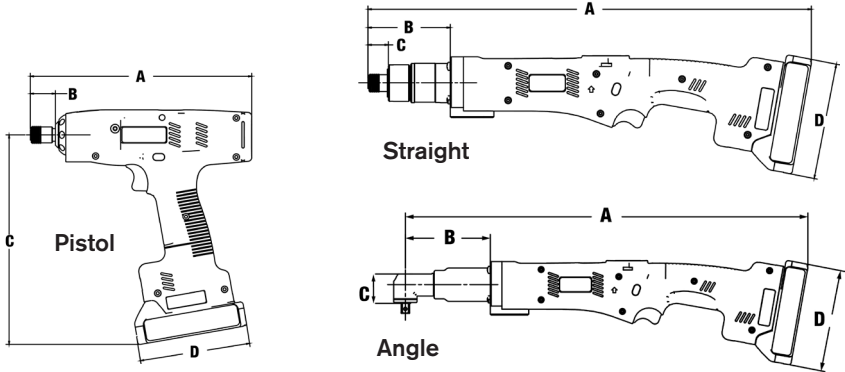

MODEL	TOOL DIMENSIONS							
	A		B		C		D	
	IN	MM	IN	MM	IN	MM	IN	MM
PISTOL								
ABP-MTA06(Q)(WQ)(BQ)(WBQ)	9.1	230	1.02	26	8.56	218	4.5	115
ABP-MTA08(Q)(WQ)(BQ)(WBQ)	9.1	230	1.02	26	8.56	218	4.5	115
ABP-MTA12(Q)(WQ)(BQ)(WBQ)	9.1	230	1.02	26	8.56	218	4.5	115
ABP-MTA17(Q)(WQ)(BQ)(WBQ)	9.1	230	1.02	26	8.56	218	4.5	115
STRAIGHT								
ABS-MTA06(Q)(WQ)(BQ)(WBQ)	17.2	437	3.19	81	0.79	20	4.5	115
ABS-MTA08(Q)(WQ)(BQ)(WBQ)	17.2	437	3.19	81	0.79	20	4.5	115
ABS-MTA12(Q)(WQ)(BQ)(WBQ)	17.2	437	3.19	81	0.79	20	4.5	115
ABS-MTA17(Q)(WQ)(BQ)(WBQ)	17.2	437	3.2	81	0.8	20	4.5	115
ANGLE								
ABN-MTA10(W)(B)(WB)	17.9	455	3.94	100	1.12	29	4.5	115
ABN-MTA17(W)(B)(WB)	18.1	461	4.14	105	1.29	33	4.5	115
ABN-MTA24(W)(B)(WB)	18.1	461	4.14	105	1.29	33	4.5	115
ABN-MTA36(W)(B)(WB)	21.6	547	7	179	1.65	42	4.5	115
ABN-MTA55(W)(B)(WB)	22.5	572	7.7	196	1.65	42	4.5	115
ABN-MTA90(W)(B)(WB)	25.9	658	10.2	259	1.8	46	4.5	115
ABN-MTA115(W)(B)(WB)	28.4	721	13.9	353	2.8	71	4.5	115

W = WiFi option B = Barcode option Q = Quick Change

7.3.0. MCA MODEL SPECIFICATIONS

MODEL	TORQUE RANGE		MAX SPEED RPM	DRIVE TYPE	WEIGHT W/O BATTERY	
	NM	FT-LB			KG	LB
PISTOL						
ABP-MCA06(Q)(WQ)(BQ)(WBQ)	1 - 6	0.8 - 4.4	1,100	1/4" QC	1.25	2.75
ABP-MCA08(Q)(WQ)(BQ)(WBQ)	1.5 - 8	1.1 - 5.9	880	1/4" QC	1.25	2.75
ABP-MCA12(Q)(WQ)(BQ)(WBQ)	2.3 - 12	1.7 - 8.9	629	1/4" QC	1.25	2.75
ABP-MCA17(Q)(WQ)(BQ)(WBQ)	3.5 - 17	2.6 - 12.5	429	1/4" QC	1.25	2.75
STRAIGHT						
ABS-MCA06(Q)(WQ)(BQ)(WBQ)	1 - 6	0.8 - 4.4	1,100	1/4" QC	1.0	2.2
ABS-MCA08(Q)(WQ)(BQ)(WBQ)	1.5 - 8	1.1 - 5.9	880	1/4" QC	1.0	2.2
ABS-MCA12(Q)(WQ)(BQ)(WBQ)	2.3 - 12	1.7 - 8.9	629	1/4" QC	1.1	2.4
ABS-MCA17(Q)(WQ)(BQ)(WBQ)	3.5 - 17	2.6 - 12.5	429	1/4" QC	1.25	2.75
ANGLE						
ABN-MCA10(W)(B)(WB)	2.5 - 10	1.9 - 7.4	629	3/8" Sq.	1.35	3.0
ABN-MCA17(W)(B)(WB)	3.5 - 17	2.6 - 12.5	420	3/8" Sq.	1.4	3.1
ABN-MCA24(W)(B)(WB)	5 - 24	3.7 - 17.7	300	3/8" Sq.	1.4	3.1
ABN-MCA36(W)(B)(WB)	8 - 36	5.9 - 26.6	165	3/8" Sq.	1.4	3.1
ABN-MCA55(W)(B)(WB)	13 - 55	9.6 - 40.6	94	3/8" Sq.	2.7	6.0
ABN-MCA90(W)(B)(WB)	18 - 90	13.3 - 66.4	70	3/8" Sq.	2.9	6.4
ABN-MCA115(W)(B)(WB)	23 - 115	17 - 84.8	56	1/2" Sq.	3.1	6.8

W = WiFi option B = Barcode option Q = Quick Change

MCA Model Dimensions

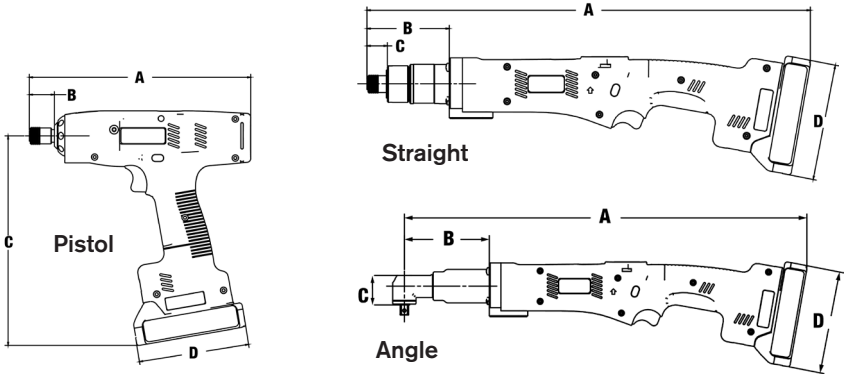

MODEL	TOOL DIMENSIONS							
	A		B		C		D	
	IN	MM	IN	MM	IN	MM	IN	MM
PISTOL								
ABP-MCA06(Q)(WQ)(BQ)(WBQ)	9.1	230	1.02	26	8.56	218	4.5	115
ABP-MCA08(Q)(WQ)(BQ)(WBQ)	9.1	230	1.02	26	8.56	218	4.5	115
ABP-MCA12(Q)(WQ)(BQ)(WBQ)	9.1	230	1.02	26	8.56	218	4.5	115
ABP-MCA17(Q)(WQ)(BQ)(WBQ)	9.1	230	1.02	26	8.56	218	4.5	115
STRAIGHT								
ABS-MCA06(Q)(WQ)(BQ)(WBQ)	17.2	437	3.19	81	0.79	20	4.5	115
ABS-MCA08(Q)(WQ)(BQ)(WBQ)	17.2	437	3.19	81	0.79	20	4.5	115
ABS-MCA12(Q)(WQ)(BQ)(WBQ)	17.2	437	3.19	81	0.79	20	4.5	115
ABS-MCA17(Q)(WQ)(BQ)(WBQ)	17.2	437	3.2	81	0.8	20	4.5	115
ANGLE								
ABN-MCA10(W)(B)(WB)	17.9	455	3.94	100	1.12	29	4.5	115
ABN-MCA17(W)(B)(WB)	18.1	461	4.14	105	1.29	33	4.5	115
ABN-MCA24(W)(B)(WB)	18.1	461	4.14	105	1.29	33	4.5	115
ABN-MCA36(W)(B)(WB)	21.6	547	7	179	1.65	42	4.5	115
ABN-MCA55(W)(B)(WB)	22.5	572	7.7	196	1.65	42	4.5	115
ABN-MCA90(W)(B)(WB)	25.9	658	10.2	259	1.8	46	4.5	115
ABN-MCA115(W)(B)(WB)	28.4	721	13.9	353	2.8	71	4.5	115

W = WiFi option B = Barcode option Q = Quick Change



CORPORATE HEADQUARTERS

10000 SE Pine Street
Portland, Oregon 97216
Phone: (503) 254-6600
Toll Free: 1-800-852-1368

AIMCO CORPORATION DE MEXICO SA DE CV

Ave. Cristobal Colon 14529
Chihuahua, Chihuahua. 31125
Mexico
Phone: (01-614) 380-1010
Fax: (01-614) 380-1019