

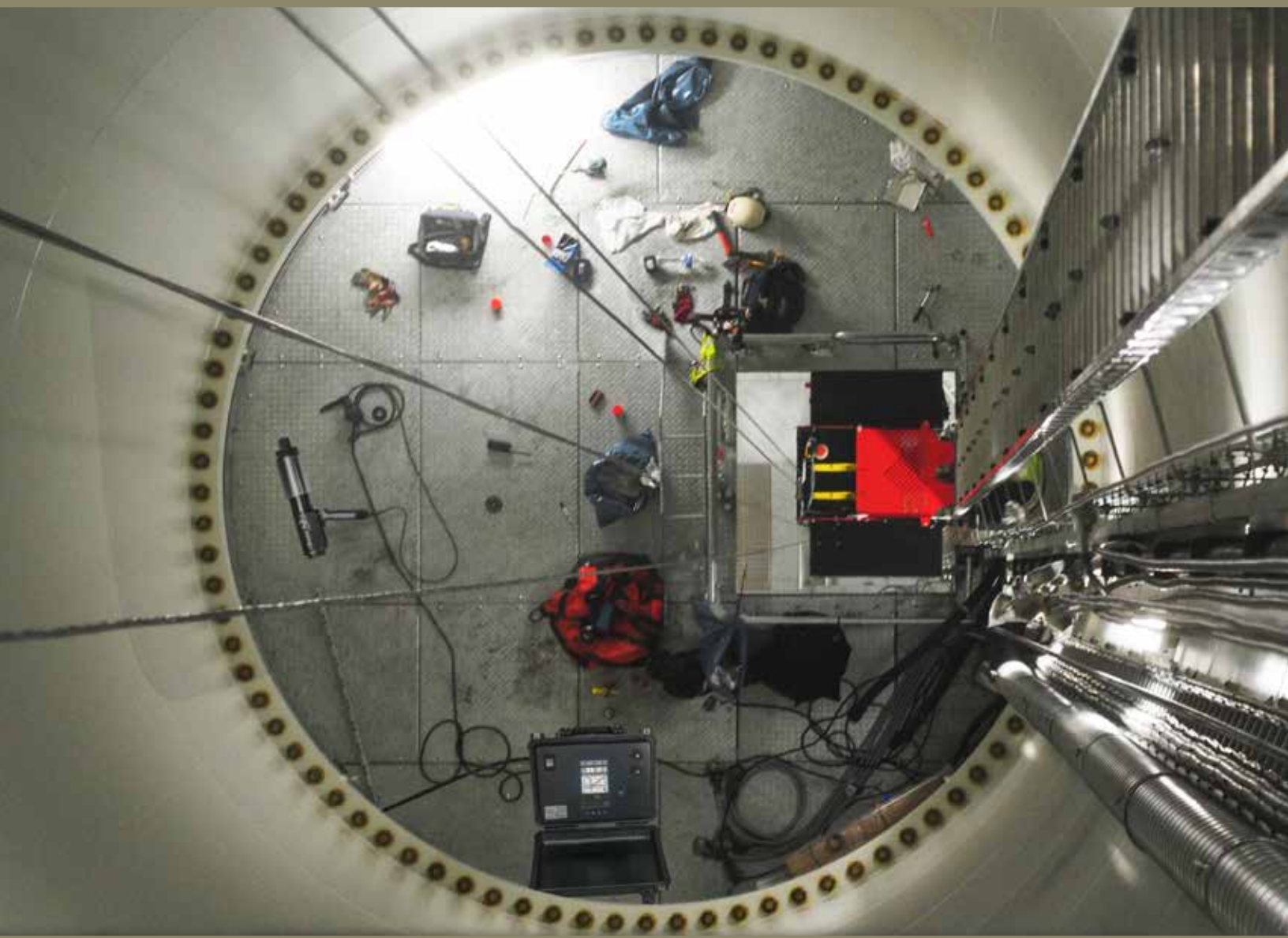

HIGH CAPABILITY BOLTING TOOLS



FOR THE WIND INDUSTRY





AcraDyne[®]
A Division of AIMCO

AcraDyne offers a full line of high torque, traceable, and critical bolting systems for the Energy Services sector: Wind Power, Solar, Nuclear, Mining, and more. AcraDyne's portfolio ranges from 1 - 17,000 Nm. Its cutting-edge high-torque bolting systems are specifically designed for critical high torque bolting applications that demand superior performance and durability. AcraDyne tools can handle the toughest and most important bolting jobs. The faster speed, coupled with its extreme accuracy, makes AcraDyne's bolting system an outstanding cost-effective investment. It is with great pride that the products that we manufacture are **DESIGNED AND ASSEMBLED IN THE USA.**

TABLE OF CONTENTS

HT Series DC Tools	4
HT Series DC Angle Tools	6
HT Series DC Dual-Lever Tools	9
HTXD Extreme Duty High Torque Tools	11
Gen IV Field Controller	14
HT Series Nose Extensions and Gearhead Tools.	16
AIMCO Cordless XT Series	17
ABP Ultra Torque Cordless Series	19
DynaTorque [®] Manual Torque Multipliers.	20
Sockets and Accessories	21



The most complete portfolio of high capability bolting and critical fastening solutions for the wind industry



All AcraDyne DC Controlled corded tools and controllers are Designed and Assembled in the USA

HIGH-TORQUE DC BOLTING TOOLS: THE DRIVING FORCE IN CRITICAL BOLTING

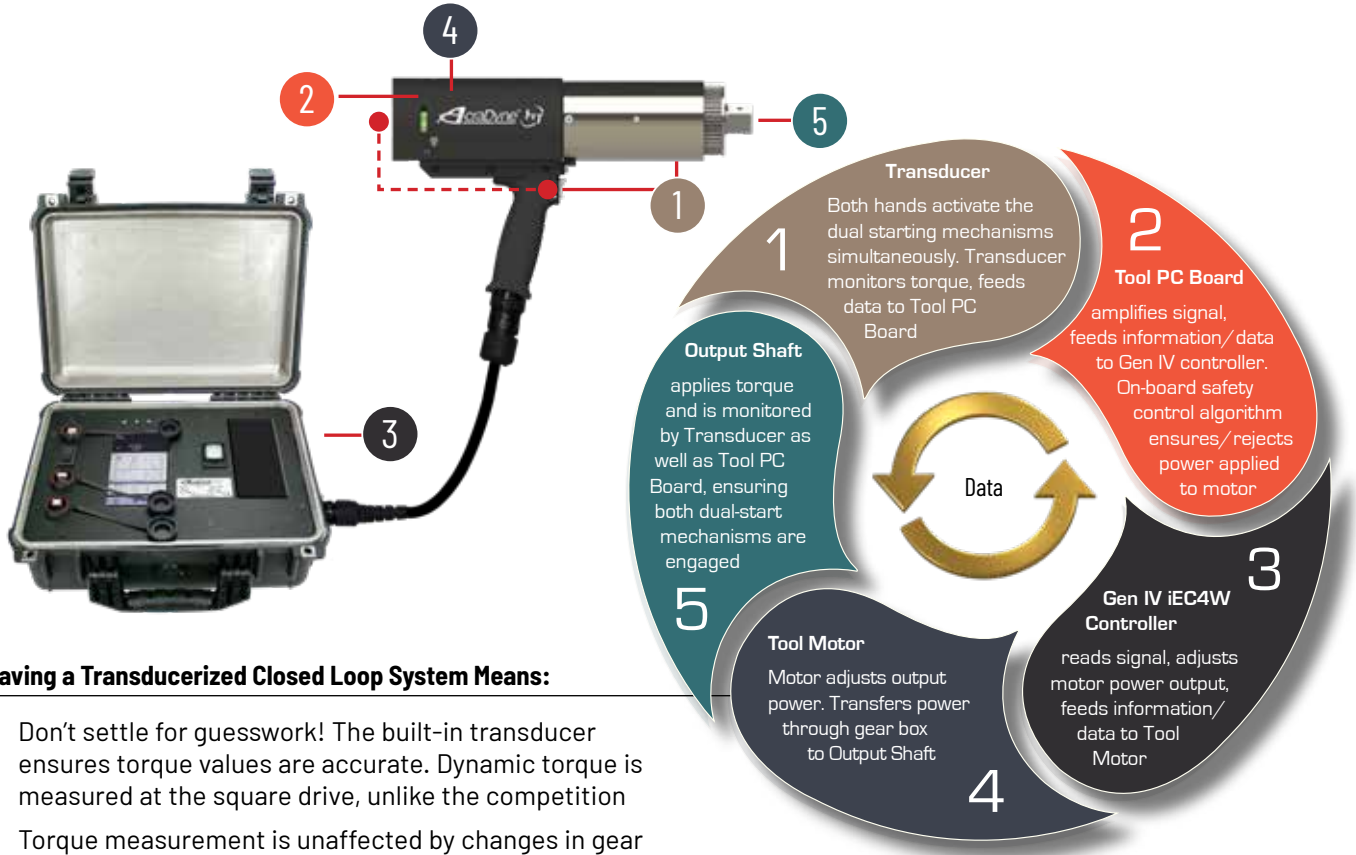





Having a Transducerized Closed Loop System Means:

- Don't settle for guesswork! The built-in transducer ensures torque values are accurate. Dynamic torque is measured at the square drive, unlike the competition
- Torque measurement is unaffected by changes in gear efficiency, normal tool wear between calibrations, temperature, voltage, or motor performance
- On-tool LEDs for Accept/Reject signals
- The system can easily be verified and calibrated anywhere
- Interchangeable tools, cables, and controllers – calibrations are specific to the tool not the system as a whole

CHOOSE YOUR HANDLE



PERQ Advantages

- | | |
|--|---|
| 
PRODUCTIVITY | <ul style="list-style-type: none"> • High tool speeds • Able to work with a single operator • Automatic evaluation and data collection |
| 
ERGONOMICS | <ul style="list-style-type: none"> • Multiple handle configuration options for optimal tool handling • Programmable acceleration to manage reaction bar behavior against reactive surface |
| 
RELIABILITY | <ul style="list-style-type: none"> • Production duty cycle durability – gearing tested to 100,000 cycles before maintenance |
| 
QUALITY | <ul style="list-style-type: none"> • Torque measurement at the output – torque delivered is the torque reported • Broad range of programmable tightening strategies to handle joint characteristics • On-board torque calibration against known standards to ensure accurate results |

360° SWIVEL GEARCASE NUTRUNNERS

Designed for Extreme Duty / Low Power Environments

FEATURES AND BENEFITS

- Built-in integral transducer for optimal monitoring and control
- One of the most accurate high-torque tools in the world
- 250 Nm - 17,000 Nm torque range
- Ergonomic, robust design with five handle configurations that are also available in dual-lever models
- The world's most advanced traceable system at the output
- Three tightening strategies:
 - *Torque Control*: Drive the tool to a pre-set Target Torque
 - *Angle Control*: Drive the tool to or measure a pre-set Degree of Angle
 - *Yield Control*: Drive the tool to the Fastener Yield Point to achieve maximum clamp load
- Data retrieval
- Optional rugged carrying/storage case available
- Optional tool fan available in models 8,100 NM and above
- DESIGNED AND ASSEMBLED IN THE USA



2,800 Nm Torque
AEP4W872800B



HT 360° Swivel Gearcase Tools

Model	Approx. Torque		Approx. Speed	Weight		Length (incl sq. dr)		Dia.		Drive	Sound Level
	NM	FT-LB	RPM	KG	LB	MM	IN	MM	IN	IN	dB(A)
Models for Extreme Duty / Low Power Environments											
Wind Series											
AE(P)(J)4W872800B	2,800	2,065	9	10.0	22	P = 406 J = 430	16 17	76	3.0	1	66
AE(P)(D)(J)4W885000B1* AE(P)(D)(J)4W885000B*	5,000	3,700	4.5	11.8	26	P = 422 D = 518 J = 446	16.6 20.4 17.6	91.2	3.6	B1 = 1 B = 1.5	66

HIGH-TORQUE ANGLE TOOLS

AcraDyne HT DC Angle Tools provide the perfect solution for space-limited applications. Compact, durable head houses a precision right-angle gearset that fits into the tightest spaces

FEATURES AND BENEFITS

- Transducerized closed loop control at the output like all AcraDyne HT-Series tools
- These low-profile head, small-diameter, lever-operated tools, with the torque measured at the output, offer a unique solution
- The torque reported is the torque delivered
- One of the most accurate high-torque right-angle tools in the world
- Smallest tools of their kind on the market
- Same durable, high-cycle gearing as our other HT-series tools
- Models up to 17,000 Nm available upon request
- These models are fixtured tools



AEN356540A



AEN3571000A



AEN3571600A



AEN3572600A

5000 Series HT Angle Tools

MODEL	Max. Torque*		Torque Range		Free Speed RPM	Weight		Output SQ Drive	Dimensions									
	NM	FT-LB	NM	FT-LB		LB	KG		A		B		C		D		E	
									IN	MM	IN	MM	IN	MM	IN	MM	IN	MM
AEN356540A	540	398	135 - 540	100 - 398	109	13.1	5.95	3/4"	22.58	573.6	2.31	58.7	4.75	120.6	4.05	102.8	1.33	33.7
AEN3571000A	1,000	737	250 - 1,000	184 - 737	61	16.3	7.39	1"	22.92	582.2	2.31	58.7	5.36	136.1	4.44	112.7	1.53	38.7
AEN3571600A	1,600	1,180	400 - 1,600	295 - 1,180	33	16.7	7.57	1"	22.92	582.2	2.31	58.7	5.36	136.1	4.44	112.7	1.53	38.7
AEN3572600A	2,600	1,917	650 - 2,600	479 - 1,917	21	18.5	8.40	1"	22.92	582.2	2.31	58.7	6.77	171.9	5.86	148.8	1.53	38.7

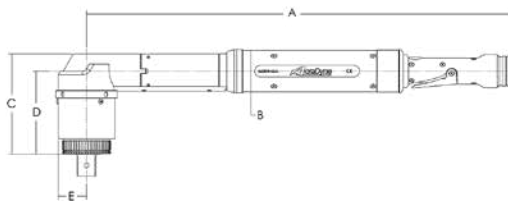

A BETTER ANGLE ON BIG JOBS



AcraDyne HT DC Angle Nutrunner is THE Tool for Servicing Blades on Wind Turbines



This **unique tool configuration**, built with all of the AcraDyne HT advantages, is made in a size that allows access to blade bolts that cannot be easily accessed by other continuous drive tools. The 360° swivel gearcase allows for precise placement of the tool reaction bar against reactive surfaces for ease of use.



AcraDyne's HT DC angle nutrunner is one of the smallest tools of its kind on the market. A powerful motor combined with a short-length handle and a 360° swivel gearcase gives you ultimate flexibility in limited-space applications.

FEATURES AND BENEFITS

- Easy access to previously hard-to-reach blade bolts
- Faster speed than hydraulic tools
- Acquires data in both loosening and retightening directions
- Preset strategies and sequencing for ease of use
- Most intuitive user interface in the industry for setup and data transfer
- Slip ring gearbox for 360° reaction bar movement
- Dual-lever option available
- Measures traceable, dynamic torque directly at the square drive, and the built-in transducer ensures accurate torque values. The torque reported is the torque delivered
- One of the most accurate high-torque right-angle tools in the world
- Same durable, high-cycle gearing as AcraDyne's industry-leading HT series tools
- Available with an optional rugged, weather-resistant carrying case



Custom reaction bars available

7000 Series HT DC Angle Tools

Model*	Max. Torque		Torque Range		Free Speed RPM	Length (Minus Reaction Bar)		Weight		Output SQ DRIVE
	NM	FT-LB	NM	FT-LB		IN	MM	LB	KG	
AEN4B771200B(DL)	1,200	885	240 - 1,200	177 - 885	38	16.6	422	17.9	8.1	1"
AEN4B773000B(DL)	3,000	2,200	600 - 3,000	443 - 2,200	15	16.6	422	20.4	9.3	1"

* Add "DL" to Part Numbers for Dual Lever

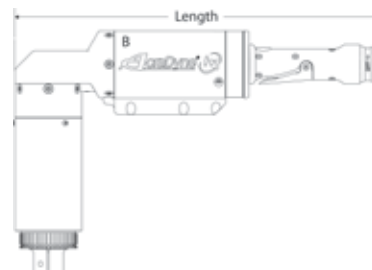

Gen IV iEC4W Field Controller: High Torque with High Tech

The Gen IV Field Controller (see page 14) is the core of the modular AcraDyne DC system. One controller will command any tool in the AcraDyne line – including the HT DC Angle Tool – from 1 Nm to 17,000 Nm, all with the same modular standard cable design.

HIGH-TORQUE DUAL-LEVER NUTRUNNERS

Provide Additional Safety by Avoiding Accidental Tool Start

FEATURES AND BENEFITS

- Built-in integral transducer for optimal monitoring and control
- One of the most accurate high-torque tools in the world
- 250 Nm - 17,000 Nm
- Two-Hand No Tie Down Operation
 - No Tie Down Control: Operator must have both hands on and activating the dual-starting mechanisms simultaneously. Both hands must remain in position, activating the dual controls, at all times in order for the tool to operate.
- Additional safety when using a tool with a reaction bar or nose extension. Operator's hands remain on the controls and not in a position where they could be impacted by reaction devices
- Hands stay clear of application
- Helps avoid accidental starting of the tool
- Available in Fixtured (F), J-Handle (J), Straight (S), as well as dual-handle configurations
- DESIGNED AND ASSEMBLED IN THE USA



AEJ Type



AEF Type



AED Type



AES Type



HT Dual-Lever Nutrunners: **SAFETY** is **VITAL** in Critical Bolting

AcraDyne's Nutrunners are designed with ultimate operator safety in mind. The optional dual-lever design helps prevent:

⚠ Injuries from Accidental Tool Start

Two-hand operation with no tie-down feature requires the operator to use both hands on the trigger simultaneously. This eliminates the possibility of accidental tool start and keeps both of the operator's hands out of harm's way.

⚠ Strain Caused by Awkward Tool Operation

Multiple handle styles ensure the safest, most ergonomic tool for your specific application.

⚠ Hand and Finger Trauma

Significantly reduce the risk of crushed or mutilated fingers from unintended tool start.

Protect your most valuable asset – your tool operator.



HT 360° Swivel Gearcase Dual-Lever Tools

Dual Lever Model	Approx. Torque		Approx. Speed RPM	Weight		Length (incl sq. dr)		Dia.		Drive IN	Sound Level dB(A)
	NM	FT-LB		KG	LB	MM	IN	MM	IN		
HT Series 360° Swivel Gearcase: Dual-Lever Models For Straight Type Tools Only: (L) = Left-Side Handle (R) = Right-Side Handle											
6000 Series											
AE (P)(F)4B66250BDL	250	185	315	4.6	10.5	P = 353 F = 369 S = 630	13.9 14.5 24.8	67.3	2.7	0.75	66
AE (S)4B66250BDL(L)(R)											
AE (F)4B66425BDL	425	315	165	4.6	10.5						
AE (S)4B66425BDL(L)(R)											
AE (F)4B66625BDL	625	460	106	4.8	10.5						
AE (S)4B66625BDL(L)(R)											
AE (F)4B66925BDL	925	682	72	4.8	10.5						
AE (S)4B66925BDL(L)(R)											
7000 Series											
AE (P)(F)4B771000BDL	1,000	738	65	6.6	14.5	P = 361 F = 343 D = 438 S = 492	14.2 13.5 17.2 19.4	77.5	3.1	1	66
AE (D)4B771000BDL(L)											
AE (S)4B771000BDL(L)(R)											
AE (D)4B771800BDL(L)	1,800	1,328	28	7.5	16.5	475	18.7	77.5	3.1	1	66
AE (P)(F)4B772500BDL	2,500	1,844	25	7.5	16.5	P = 398 F = 379 D = 475 S = 528	15.7 14.9 18.7 20.8	77.5	3.1	1	66
AE (D)4B772500BDL(L)											
AE (S)4B772500BDL(L)(R)											
8000 Series											
AE (P)(F)4B896500BDL	6,500	4,800	5	16.4	36	P = 475 F = 499	18.7 19.7	104	4.1	1.5	66
AE (J)4B898100BDL*	8,100	6,000	5	16.4	36	499	19.7	104	4.1	1.5	66

* 8,100 Nm - 17,000 Nm models are not supported by the Gen III controller platform. The Gen IV controller platform is required.

EXTREME DUTY



Full-Strength Tools for Big Jobs

AcraDyne's HTXD Nutrunner/Gen IV Controller System is one of the Most Accurate High-Torque Bolting Systems in the World



- Measures traceable, dynamic torque directly at the square drive, and the built-in transducer ensures accurate torque values. The torque reported is the torque delivered
- Available in J handle and Pistol handle configurations
- Extreme Duty engineering with motors rated for bolting applications near continuous duty
- Patented dual J-Handle models have additional safety features: Operators must use both hands on the trigger simultaneously, eliminating the possibility of accidental tool start and keeping both of the operator's hands out of harm's way
- Wide range of tightening strategies available including Torque Control, Torque plus Angle, Angle Control, and Yield Control

AcraDyne® HTXD **EXTREME DUTY**

AcraDyne's HTXD Systems measure traceable, dynamic torque directly at the square drive and the built-in transducer ensures accurate torque values.

- Accuracy and traceability are assured from the first fastening to the last
- Torque reported is the torque delivered
- Accuracy not affected by gearing efficiency

Tools with the gearing after the transducer cannot claim this!



Pistol Model
12,000 Nm



J-Handle Model
12,000 Nm



Fixtured Model
6,500 Nm



12,000 Nm



17,000 Nm
U.S. Patent D968491

HT 360° Swivel Gearcase Bolting Tools for Extreme Duty

Model	Series	Approx. Torque		Approx. Speed RPM	Weight *		Length (incl sq. dr)		Dia.		Drive IN	Sound Level dB(A)
		NM	FT-LB		KG	LB	MM	IN	MM	IN		
Fixed Gearcase												
AEF4A996500B	9000	6,500	4,800	5.8	19	42	494	19.5	104	4.1	1.5	66
360° Swivel Gearcase												
AEP4W998100B	9000	8,100	6,000	2.3	21.8	48	544	21.4	104	4.1	1.5	66
AEJ4W998100B	9000	8,100	6,000	2.3	21.8	48	544	21.4	104	4.1	1.5	66
AEJ4U998100BDL	9000	8,100	6,000	2.3	21.8	48	427	16.8	104	4.1	1.5	66
AEP4W9X12000B	9X	12,000	8,850	2	31.8	70	572	22.5	131	5.2	1.5	66
AEJ4W9X12000B	9X	12,000	8,850	2	31.8	70	572	22.5	131	5.2	1.5	66
AEJ4U9X12000BDL	9X	12,000	8,850	2	31.8	70	441	17.4	131	5.2	1.5	66
AEP4W9Y17000B	9Y	17,000	12,500	1	42.6	94	381	15	153	6.0	2.5	66
AEJ4W9Y17000B	9Y	17,000	12,500	1	42.6	94	381	15	153	6.0	2.5	66
AEJ4U9Y17000BDL	9Y	17,000	12,500	1	42.6	94	458	18	153	6.0	2.5	66

* Weight is tool only w/o Socket and Reaction Bar

Ultimate Operator Safety for Lifting Larger Bolting Tools

AcraDyne's XD Lift Assist device for tool suspension and use allows for easy handling of equipment that otherwise would need two operators to position.

FEATURES AND BENEFITS

- Lift can be assembled/disassembled in less than 15 minutes
- Can be used inside wind turbines at deck platforms
- Designed for a wide variety of applications including narrow tower platforms and ladder spaces
- Lift Assist weighs 30 kg / 67 lbs
- Weight of unit is below the weight allowed to be lifted by personnel inside or outside the tower
- Disassembled Lift Assist is transported in a load-rated bag that can be lifted manually or by hoist within the tower
- Device is rated for loads up to 200 kg / 440 lbs
- Full-swivel wheels with locking brakes make movement and repositioning easy

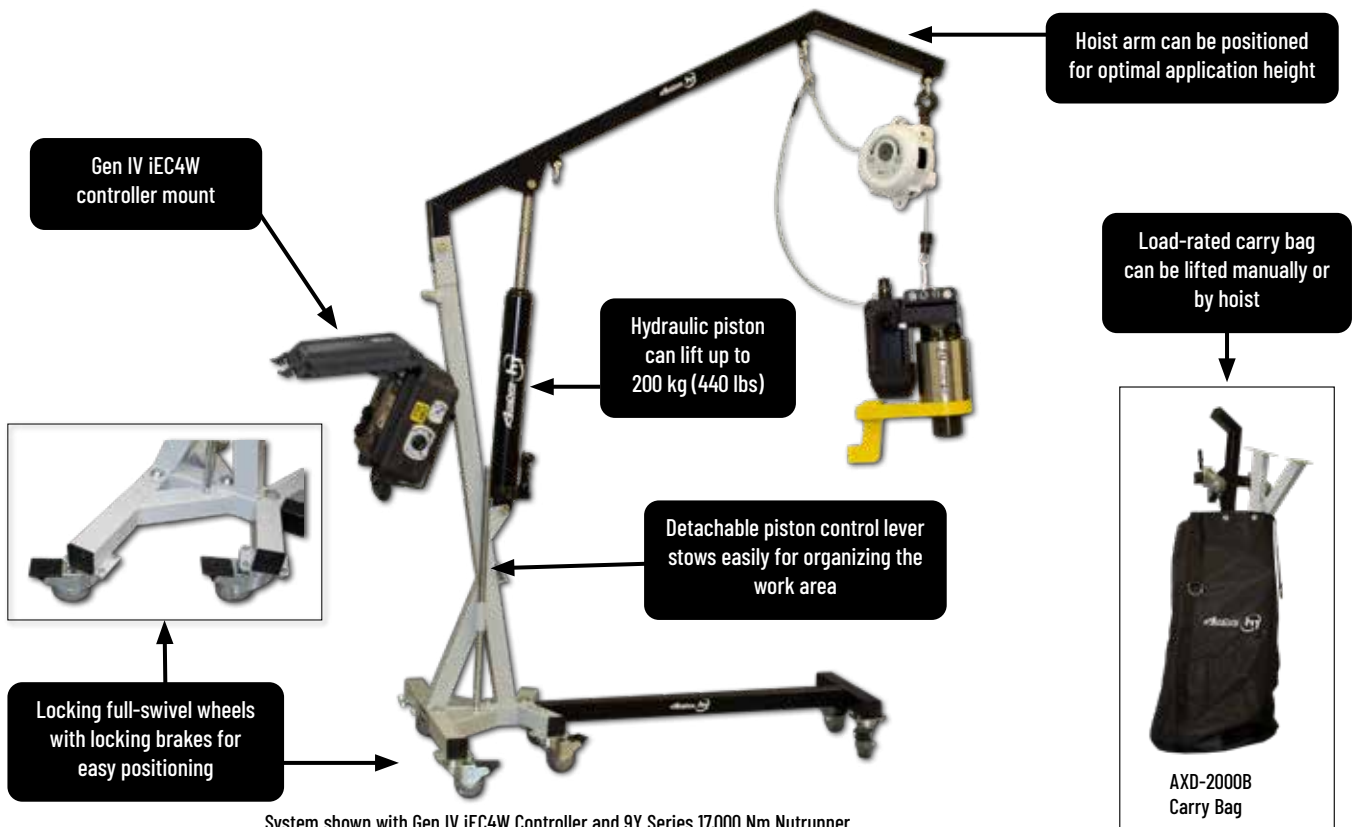

System shown with Gen IV iEC4W Controller and 9Y Series 17,000 Nm Nutrunner Controller and tool sold separately

GEN IV FIELD CONTROLLER

Improved design of AcraDyne's powerful Gen IV Field Controller means increased durability, lighter weight, and quick and easy setup



iEC4WF Field Controller



Rugged, Lightweight Case

FEATURES AND BENEFITS

- Optimized for extreme duty applications >5,000 Nm
- The Gen IV Controller utilizes three tightening strategies:
 - Torque Control: Drive the tool to a pre-set Target Torque
 - Angle Control: Drive the tool to or measure a pre-set Degree of Angle
 - Yield Control: Drive the tool to the Fastener Yield Point to achieve maximum clamp load
- Multiple fastening strategies – Program up to 256 parameters with as many as 20 steps
- Jobs capability – 99
- Real-time curve viewing. Curve storage – 20,000
- Rundown storage – 1,000,000
- Event log – 5,000
- Backup & restore through USB
- Weatherproof, rugged case protects from the toughest environments
- Compact design weighs less than 20 lbs
- Ground clamp is quick and easy to set up and eliminates additional parts that are substantially heavy
- Optional tool fan kit helps prevent tool overheating
- Capable of interface with the AcraDyne series Dual-Lever tools that offer two-hand, no tie down functionality
- 110V – 220V compatible
- Single Ethernet port increases speed of connectivity, signal stability, and signal consistency
- Commands any tool in the AcraDyne line from 1 Nm to 17,000 Nm, all with one cable

PERQ Advantages



PRODUCTIVITY

- Replace multiple conventional tools with one flexible controlled system
- Quick and easy setup
- Fan kit reduces downtime due to tool overheating



ERGONOMICS

- Compact, rugged case with easy carry handle makes field use easy and convenient
- Lightweight for operator comfort



RELIABILITY

- Weatherproof rugged case
- Industrial touch screen



QUALITY

- Controlled tightening and consistent torque control improves quality
- Process controls reduce human error, and ensure no missed fasteners, stripped threads, rehits, or damaged threads
- No premature shut-off

Model	Description	Dimensions W x D x H	Weight	
			LB	KG
iEC4WF	Field use controller for use with 110V or 220V service	16.1" x 12.8" x 6.9" 408 mm x 326 mm x 175 mm	18.5	8.4

GEN IV FIELD CONTROLLER SOFTWARE

AcraDyne's software package is on-board every AcraDyne controller and is provided FREE of charge. This comprehensive, user-friendly program allows programming, analysis, and diagnostics.

The software is based on a standard web browser, allowing you to connect the AcraDyne controller with any computer, tablet, or smart device. Connect through Ethernet, USB, or wirelessly via a network connected to both devices.

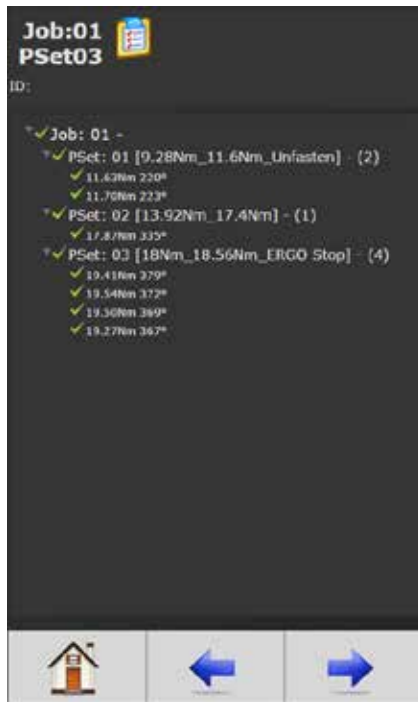

Adding and editing Parameter Sets (256) and Jobs (99) is easy and intuitive in the parameter set up function.



View curve results in real time or view stored results. As many as 20,000 curve results can be stored in memory.

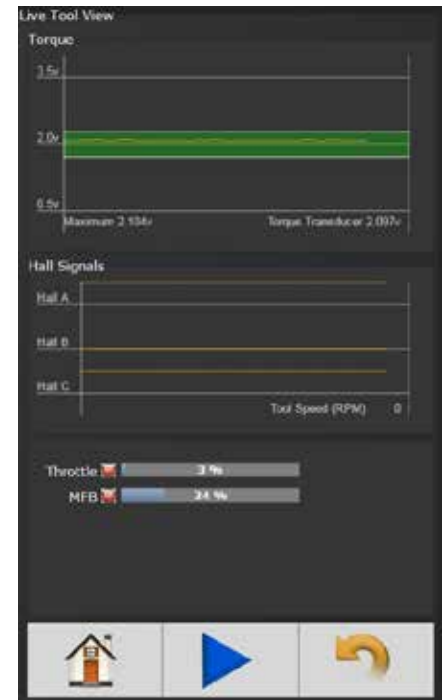

Tool programming and diagnostics for repair, calibration and advanced troubleshooting.



Choose from several run screens that display easy to view, large screen indicators.

NOSE EXTENSIONS AND GEARHEAD TOOLS



NOSE EXTENSIONS

FEATURES AND BENEFITS

- Ideal for hard-to-reach applications when a torque tube, or arm, is not desirable
- A cost-effective, more flexible option compared to a multiple spindle system
- Common applications:
 - Wheel install and repair stations
 - Large flange assembly
 - Mining vehicle shovel bolts
 - Railway equipment maintenance
 - Oil and gas industry well fixtures

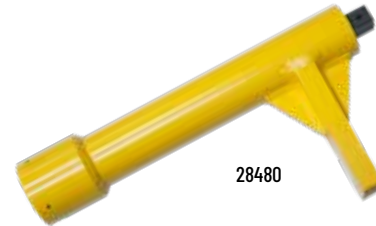

HT GEARHEAD TOOLS

FEATURES AND BENEFITS

- Application-specific, custom made tools fit virtually any application
- Same durable gearing as found on AcraDyne's standard HT series tools
- Model types available:
 - HT Offset Gearhead tools
 - HT Right Angle with Offset Gearhead tools
 - HT Right Angle Air tools with Offset Gearhead

Custom accessories are available for your application. Contact an AIMCO Customer Service Associate for more details, 1-503-254-6600, or toll free 1-800-852-1368.



CORDLESS XT SERIES

Transducerized Cordless Freedom for Your Bolting Applications



AIMCO's XT Series Cordless Tool is an excellent choice for any application that requires flexibility and uninterrupted operation. These high-efficiency tools feature a brushless motor and provide three selectable tightening strategies: Torque Control, Torque Control with Angle Reporting, and Angle Control with Torque Reporting.

The built-in transducer means precise measurement and traceability. The digital display panel facilitates programming, allows changes in preset values and strategies, and accesses stored information. User interface software is available at no cost to the user and has no licensing requirements.



FEATURES AND BENEFITS

- Built-in transducer for measurement and traceability
- Torque overload limit function removes responsibility from the operator
- Ultimate flexibility with three selectable tightening strategies:
 - Torque Control
 - Torque Control with Angle Monitor
 - Torque Control plus Angle
- Temperature-monitoring sensor helps prevent overheating
- High-efficiency brushless motor provides longer motor life and increased efficiency
- Monitor and review reliable data with results stored on tool log and easily extractable through USB
- User-friendly digital adjustment and display of wrench status provides quick operator feedback
- Anti-Windup feature facilitates release from application
- Batteries and charging systems readily available from many sources



ABETP Series Tool with Custom AcraDyne Reaction Bar

Many custom reaction devices are available. Contact an AIMCO Customer Service Associate for more details, 1-503-254-6600, or toll free 1-800-852-1368.



Digital Display and Control Interface

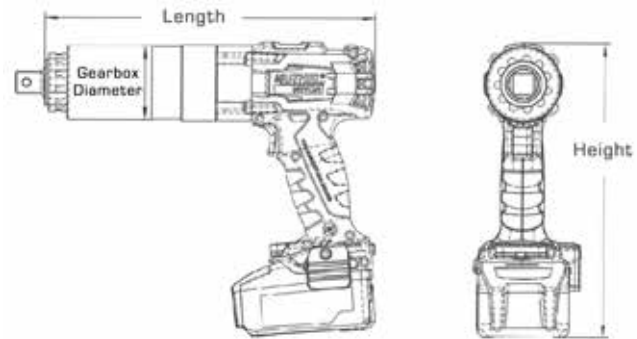

AcraDyne Cordless XT Series Tools

Model*	Torque Range**		Drive Size IN	RPM	Length		Height		Gearbox Dia.		Weight		Noise Level dB(A)
	NM	FT-LB			MM	IN	MM	IN	MM	IN	KG	LB	
ABETP-350 (-KIT-120V) (-KIT-220V)	100 - 350	74 - 258	3/4"	15	206	8.1	267	10.5	68	2.7	2.9	6.4	80
ABETP-500 (-KIT-120V) (-KIT-220V)	150 - 500	110 - 370	3/4"	10	206	8.1	267	10.5	68	2.7	2.9	6.4	80
ABETP-800 (-KIT-120V) (-KIT-220V)	230 - 800	170 - 590	3/4"	6	253	10	267	10.5	68	2.7	3.3	7.3	80
ABETP-1400 (-KIT-120V) (-KIT-220V)	300 - 1,400	220 - 1,030	3/4"	6	253	10	267	10.5	68	2.7	3.3	7.3	80
ABETP-1700 (-KIT-120V) (-KIT-220V)	550 - 1,700	405 - 1,250	1"	4	328	12.9	267	10.5	78	3.1	5.3	11.7	80
ABETP-2800 (-KIT-120V) (-KIT-220V)	700 - 2,800	515 - 2,065	1"	3.5	316	12.4	267	10.5	78	3.1	5.8	12.8	80
ABETP-3100 (-KIT-120V) (-KIT-220V)	900 - 3,100	664 - 2,285	1"	2.5	316	12.4	267	10.5	78	3.1	5.8	12.8	80
ABETP-3500 (-KIT-120V) (-KIT-225V)	350 - 3,500	258 - 2,582	1"	2	312	12.3	267	10.5	82	3.2	6.1	13.4	80
ABETP-4000 (-KIT-120V) (-KIT-220V)	810 - 4,000	595 - 2,950	1"	2	312	12.3	267	10.5	82	3.2	6.1	13.4	80
ABETP-4500 (-KIT-120V) (-KIT-220V)	1200 - 4,450	885 - 3,282	1"	2	370	14.6	267	10.5	86	3.4	8.1	17.9	80

* Base model comes with no battery. Base model includes tool and standard reaction bar. Batteries are available separately or in tool/kits combinations.

**Tools should be sized to be used at no more than 80% of their maximum torque capability.

Add "-KIT" to the end of the model number to order a tool kit, which includes 1 tool, 2 batteries, and 1 battery charger. The part number must also specify "120V" or "220V" depending on power requirements.

Li-Ion HD BATTERY AND CHARGER



18V Li-Ion Battery
625368000

Battery Charger
120V: 627046000
220V: 627044000

- 5.5 Ah 18V Li-Ion battery
- LiHD battery provides ultimate performance and extremely long use with minimal temperature variation
- Air cooled charging technology: Battery pack cools during charging, significantly reducing charging times
- Processor-controlled charge and discharge management
- Battery can be stored with almost no self-discharge

Ultra Torque ABP-CTA Series

Unmatched Accuracy for Higher-Torque Applications

FEATURES AND BENEFITS

- Transducerized for precise delivery of torque and angle to the fastener
- Usable stand-alone or with AcraDyne iBC series Controller for line controls and/or data integration with QMS systems
- Sophisticated control set with AcraDyne Tool Manager program with 99 PSETS available
- Operator feedback with OLED screen, audible and tactile feedback
- Wide variety of strategies
 - Torque
 - Angle
 - Torque Plus Turn
 - Torque Minus Turn
 - And more...
- Available with Two-Hand, No Tie Down Button to ensure operator safety from accidental contact with reaction bar
- Standard Offset, Deep Offset, and Flat Reaction Bars available. Custom reaction bars available by request
- Tool supplied with one battery (P/N AB-B1850LI), and standard reaction bar. Charger is purchased separately:
 - AB-C18110 (120VAC) Charger or
 - AB-C18220 (220VAC) Charger



AcraDyne Cordless ABP-CTA Ultra Torque Series Tools

Model	Max Torque		Max Speed RPM	Length		Weight	Gearbox Diameter	
	NM	FT-LB		MM	IN		MM	IN
ABP-CTA250W	250	185	27	335	13.2	w/out battery: 3.7 kg / 8.04 lb w/battery: 4.3 kg / 9.44 lb	67	2.6
ABP-CTA450W	450	332	14	335	13.2	w/out battery: 3.7 kg / 8.04 lb w/battery: 4.3 kg / 9.44 lb	67	2.6
ABP-CTA650W	650	480	9.4	335	13.2	w/out battery: 3.7 kg / 8.04 lb w/battery: 4.3 kg / 9.44 lb	67	2.6
ABP-CTA950W	950	700	6.4	335	13.2	w/out battery: 3.7 kg / 8.04 lb w/battery: 4.3 kg / 9.44 lb	67	2.6
ABP-CTA1400W	1,400	1,000	4	338	13.3	w/out battery: 4.0 kg / 8.85 lb w/battery: 5.1 kg / 11.25 lb	77.5	3.1
ABP-CTA3000W	3,000	2,200	2.1	374	14.7	w/out battery: 5.6 kg / 12.31 lb w/battery: 6.2 kg / 13.71 lb	77.5	3.1
ABP-CTA5000W	5,000	3,688	1.3	418	16.5	w/out battery: 7.9 kg / 17.4 lb w/battery: 8.5 / 18.8 lb	91.2	3.6

W = WiFi



MANUAL TORQUE MULTIPLIERS



FEATURES AND BENEFITS

Manual Torque Multipliers offer the perfect, economical solution to high torque bolting applications.

- Superior power to weight ratio
- Delivered torque accuracy +/- 4%
- Anti-Wind Up safety feature (2,800 NM models and up) prevents input device from springing backward when released
- True torque multiplication ratios
- Standard reaction arms supplied. Custom reaction arms/nose extensions available to suit specific applications
- No preventative maintenance required
- Overload protected by shear-drive design (spare torsion shaft included). Easily replace sheared-off pins at the work site

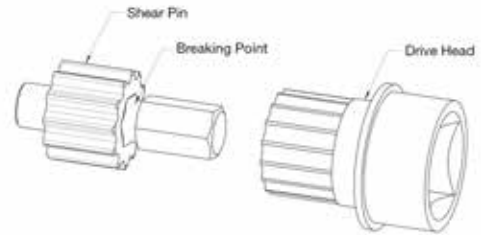

DynaTorque Manual Torque Multipliers

Model	Input IN	Output IN	Ratio	Max Torque Output		A (MM)	B (MM)	C (MM)	D (MM)	Weight*	
				Nm	Ft-Lb					LB	KG
ATM-800	1/2	3/4	1:3.5	800	590	65	105	132	130	2.9	1.3
ATM-1800	3/4	1	1:3.6	1,800	1,327	90	150	188	132	6.6	3.0
ATM-2800	1/2	1	1:13	2,800	2,066	95	200	240	132	11.5	5.2
ATM-3800	3/4	1	1:13	3,800	2,804	95	200	240	132	11.5	5.2
ATM-5000	3/4	1.5	1:17	5,000	3,690	120	215	272	150	15.4	7.0
ATM-8000	3/4	1.5	1:49	8,000	5,904	132	268	344	200	25.4	11.5
ATM-12000	3/4	1.5	1:58	12,000	8,856	156	272	348	200	30.9	14.0
ATM-16000	3/4	2.5	1:75	16,000	11,808	215	292	370	225	57.3	26.0

* Weight shown does not include weight of reaction device.

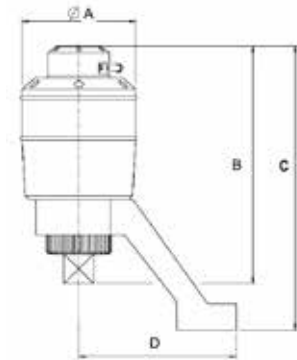

CARRYING CASE

All DynaTorque Multipliers are supplied in a rugged, weather-resistant, portable carrying case.



SOCKETS & ACCESSORIES

In addition to the models presented below, a wide variety of sockets and extensions are available.
Call 1-503-254-6600, or toll free 1-800-852-1368 for more information.

IMPACT SOCKETS

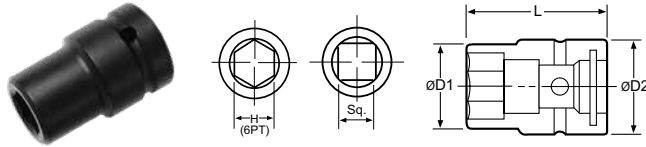

	Part No	Hex	D1 MM	D1 IN	D2 MM	D2 IN	L MM	L IN
1" Square Drive								
SAE	A87/8	7/8"	37	1.46	54	2.13	59	2.32
	A815/16	15/16"	38	1.50	54	2.13	59	2.32
	A81	1"	41	1.61	54	2.13	59	2.32
	A81-3/16	1-3/16"	50	1.97	54	2.13	61	2.41
METRIC	A817	17 mm	31	1.22	50	1.97	63	2.48
	A819	19 mm	33	1.30	50	1.97	63	2.48
	A821	21 mm	37	1.46	50	1.97	63	2.48
	A836	36 mm	57	2.24	55	2.17	65	2.56
1-1/2" Square Drive								
SAE	A142-1/8	2-1/8"	84	3.31	84	3.31	87	3.43
	A142-1/2	2-1/2"	97	3.82	86	3.39	100	3.94
	A143-1/2	3-1/2"	130	5.12	86	3.39	120	4.72
	A144-1/4	4-1/4"	155	6.10	102	4.02	140	5.51
METRIC	A1465	65 mm	99	3.90	86	3.39	100	3.94
	A1475	75 mm	112	4.41	86	3.39	110	4.33
	A1485	85 mm	125	4.92	86	3.39	120	4.72
	A14105	105 mm	151	5.95	102	4.02	130	5.12
2-1/2" Square Drive								
SAE	A242-3/8	2-3/8"	100	3.94	137	5.39	130	5.12
	A242-3/4	2-3/4"	110	4.33	137	5.39	130	5.12
	A243-1/4	3-1/4"	130	5.12	137	5.39	130	5.12
	A243-7/8	3-7/8"	148	5.83	137	5.39	140	5.51
METRIC	A2460	60 mm	100	3.94	137	5.39	130	5.12
	A2480	80 mm	125	4.92	137	5.39	130	5.12
	A24110Z	110 mm	162	6.38	137	5.39	150	5.91
	A24150	150 mm	219	8.62	160	6.30	170	6.69

ALLEN SOCKETS

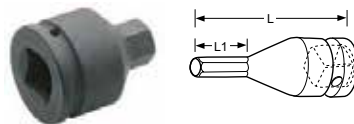

Part No	Hex	L1 MM	L1 IN	L MM	L IN
1-1/2" Allen Socket					
A1432CZ	32 mm	20.5	1.26	120	4.72

Many other allen sockets are available, including:

1" x 19 mm	1-1/2" x 19 mm
1" x 22 mm	1-1/2" x 22 mm
1" x 24 mm	1-1/2" x 24 mm
1" x 27 mm	1-1/2" x 36 mm

Contact an AIMCO Customer Service Associate for ordering options,
1-503-254-6600, or toll free 1-800-852-1368.



ERGO-DRIVE SOCKETS

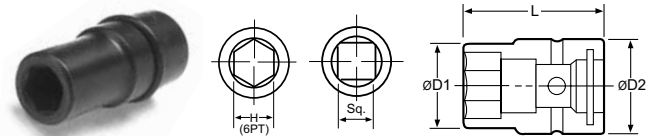

Part No	Hex	D1 MM	D1 IN	D2 MM	D2 IN	L MM	L IN
1" Square Drive							
A815/16EDS	15/16"	38	1.50	54	2.13	69	2.72
A8100EDS	100 mm	136	5.35	76	2.99	120	4.72

ERGO-DRIVE EXTENSIONS

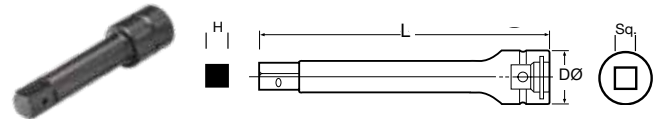

Part No	Sq Drive	H	L MM	L IN	D MM	D IN
1" Square Drive						
A8150EDE	1"	1"	150	5.91	54	2.13
A8200EDE	1"	1"	200	7.87	54	2.13

ACCESSORIES

Custom accessories are available for your application; contact an AIMCO Customer Service Associate for details, 1-503-254-6600, or toll free 1-800-852-1368.







Model	Description
26477	Swivel Bail, 6000 Series
26327	Swivel Bail, 7000 Series
25287	Swivel Bail, 8000 Series
26630	Swivel Bail, 8000/9000 Series Tools
26478	Swivel D-Handle, 6000 Series
26328	Swivel D-Handle, 7000 Series
25291	Swivel D-Handle, 8000 Series
26479	Stationary Bail, 6000 series (26336 handle not included)
26332	Stationary Bail, 7000 series (26336 handle not included)
25289	Stationary Bail, 8000 series (26336 handle not included)
26336	Fixed Handle (for use with 26479, 26332, 25289)
26337	Rear Fixed Hoist Ring, 6000/7000/8000 Series Pistols
28514	Rear Folding Hoist Ring Kit for 8000 Series Pistols
28549	Sliding Spindle, 6000 Series
27045	Sliding Spindle, 7000 Series
30300	Sliding Spindle, 8000 Series

REACTION BARS



HT tool includes a standard, spline attachment reaction device. Custom reaction devices are available. Contact an AIMCO Customer Service Associate for more details, 1-503-254-6600, or toll free 1-800-852-1368.

	Model	Description
 Single Ended Flat	26810	6000 Series
	26800	7000 Series
	25277	8000 Series
	27255	9000 Series
	30303	X Series
 Single Ended Offset	26815	2.375" Offset, 6000 Series
	26885	4.00" Offset, 6000 Series
	27200	3.10" Offset, 7000 Series
	26890	4.00" Offset, 7000 Series
	25274	3.35" Offset, 8000 Series
	25275	4.00" Offset, 8000 Series
	26840	3.35" Offset, 9000 Series
	30306	5.00" Offset, X Series
31273	5.00" Offset, Y Series	
 Double Ended Flat	26830	6000 Series
	26820	7000 Series
	25278	8000 Series
 Double Ended Offset	25276	3.35" Offset, 8000 Series

PROTECTIVE COVERS

Durable protective covers prevent marring and damage.



Model	Description
BJ10078	Protective Cover, 6000 Series
BJ10077	Protective Cover, 7000 Series
BJ10076	Protective Cover, 8000 Series

HEAVY DUTY WATER-RESISTANT CASE FOR HT TOOLS



Made of ultra high-strength polypropylene copolymer resin, this water resistant utility case protects AcraDyne HT tools.

- Molded-in hinge, trigger-release latch system, and snap-down cushion grip handle
- Resistance to UV, solvents, corrosion, and impact damage

Model	Compatible Tools	Description
CC-6000-F	6000 series	Case with molded foam insert
CC-6000-FIP	6000 series	Case with foam in place
CC-7000-F	7000 series	Case with molded foam insert
CC-7000-FIP	7000 series	Case with foam in place
CC-8000-F	8000 series	Case with molded foam insert
CC-8000-FIP	8000 series	Case with foam in place

Please contact an AIMCO Customer Service Associate for details, 1-503-254-6600, or toll free 1-800-852-1368.

ACCESSORIES

CABLE ASSEMBLIES



The AcraDyne DC electric nutrunner tool system uses a single cable to carry all necessary conductors for superior ergonomics and durability.

- Flexible polyurethane cover for maximum durability, abrasion and transmission fluid resistant
- Quick disconnects at both ends facilitate tool changeover and troubleshooting
- The CAN data/signal is via RJ45 for products such as the KDM socket tray or computer



Model	Description	Length	
		M	Ft
Tool Cables			
24330	G3/G4 Tool Cable 3M	3	9.8
25350	G3/G4 Tool Cable 5M	5	16.4
24320	G3/G4 Tool Cable 10M	10	32.8
Extensions			
24320	Extension cable 10M	10	32.8
25518	Extension cable 20M	20	65.6

CABLE ADAPTERS AND CONNECTORS

	Model	Description
Adapters and Connectors		
	26364	G3/G4 Right Angle Cable Adapter
	25491	G3/G4 Breakaway Cable Connector - Ensures disconnect of cable should stress in excess of 40 lbs. occur (see below)

BREAKAWAY CABLE CONNECTOR

Innovative Quick Disconnect Device reduces cable damage from dropping tools or pulling cables when in use.



- Easily snaps into place, using magnetic force, at either the tool or the controller
- Adjust holding force by removing or adding magnets. Max holding force is 40 lbs / 18 kg

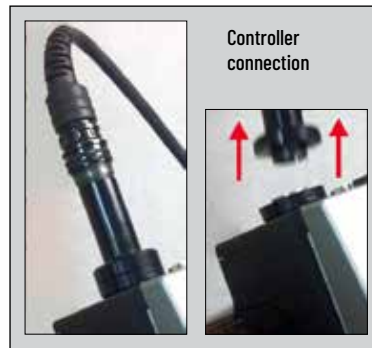

AHCTS TEST STAND FOR ROTATING TOOLS



Designed for testing tools with continuous rotating output spindles. The test stand includes a rundown fixture, bushing for side load support, reaction post or reaction paddles, transducer, and torque analyzer display.

Model	Rundown Fixture Capacity	Description
AHCTS-2500	250 ft-lbs - 2,500 ft-lbs 340 Nm - 3,390 Nm	1.5" Sq. Dr. w/rundown fixture*
AHCTS-5000	500 ft-lbs - 5,000 ft-lbs 678 Nm - 6,780 Nm	1.5" Sq. Dr. w/rundown fixture*
AHCTS-7500	750 ft-lbs - 7,500 ft-lbs 1,016 Nm - 10,168 Nm	1.5" Sq. Dr. w/rundown fixture

*Adapters for 3/4" drive and 1" drive are available. Consult your AcraDyne HT representative for details, 1-503-254-6600, or toll free 1-800-852-1368.

ACCESSORIES

PORTABLE RUNDOWN FIXTURE



Eliminate the need for high-cost, heavy, and cumbersome test stands. This portable, lightweight, and easy-to-use rundown fixture requires virtually no set-up and is ideal for tool-run tests up to 1,000 Nm. With a reaction bar attached, run one bolt down to torque while using the second bolt as the reaction point.

FEATURES AND BENEFITS

- Two bolts – one for rundown, one for reaction
- No clamping or securing necessary
- Can be used with medium or hard joint
- Easy to adjust reaction bolt
- Grade 5 bolts provide durability (lithium grease included)
- Rundown fixture includes:
 - A62-1/16Z Socket for 3/4" Sq. Dr. Tools
 - A82-1/16Z Socket for 1" Sq. Dr. Tools
- Recommended:
 - 30951 Grade 5 Replacement Bolt

Model	Max. Torque Capacity	Width		Weight	
	NM	IN	MM	KG	LB
30955	1,000	8.50	215.9	5.6	12.45

When used with recommended AIMCO sockets, reaction bar geometry is a standard offset (2" - 3.5")



HIGH-TORQUE TOOL SPECIALS

AIMCO can provide customized tooling solutions for even the most unique applications. Let us propose a solution tailored to your needs. Contact an AIMCO Customer Service Associate for more details, 1-503-254-6600, or toll free 1-800-852-1368.



The most complete portfolio of high capability bolting and critical fastening solutions for the wind industry





CORPORATE HEADQUARTERS

10000 SE Pine St.
Portland, Oregon 97216
Phone: (503) 254-6600
Toll Free: 800-852-1368

AIMCO CORPORATION DE MEXICO SA DE CV

Ave. Cristobal Colon 14529
Chihuahua, Chihuahua. 31125
Mexico
Toll Free : (01-800) 801-1600
Direct : (01-614) 380-1010
Fax: (01-614) 380-1019