

UL-60, UL-60D SERIES OIL-PULSE WRENCHES

EXPLODED VIEW

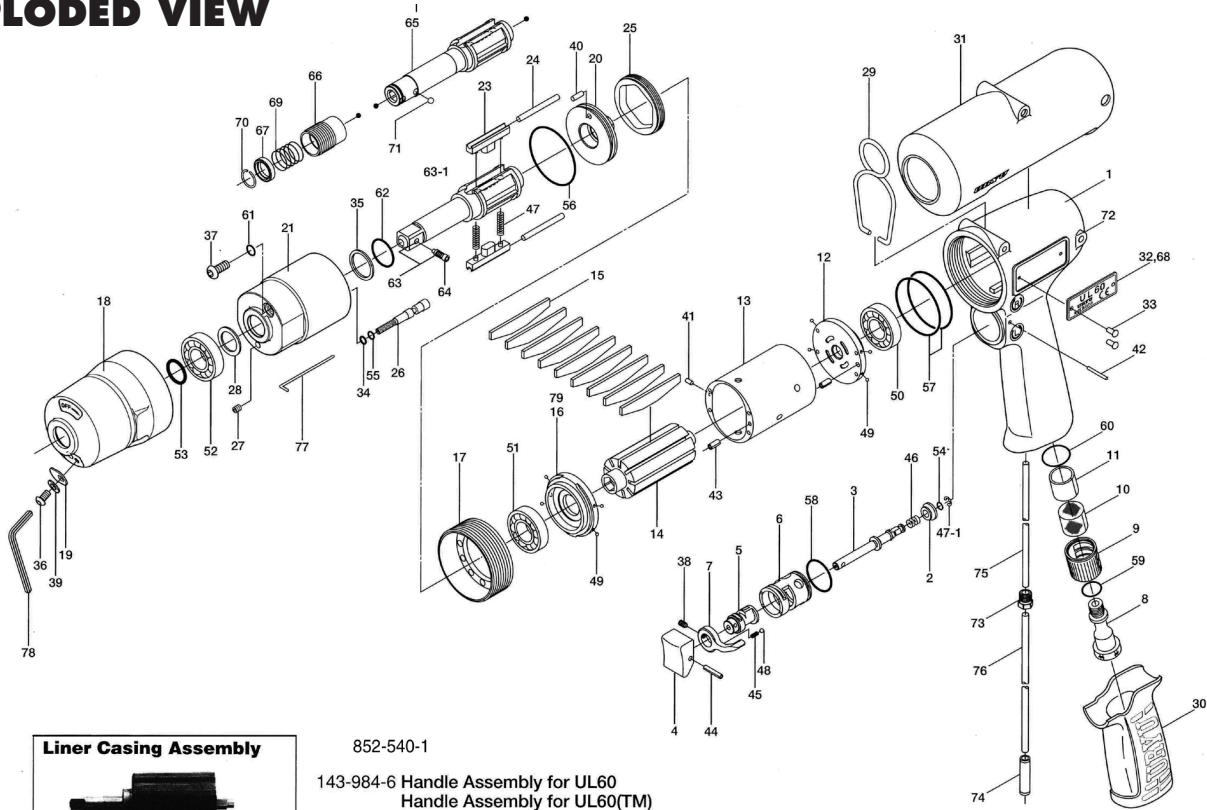

Liner Casing Assembly
Code No. 891-474-1 for UL60
Code No. 143-911-7 for UL60D

852-540-1
143-984-6 Handle Assembly for UL60
Handle Assembly for UL60(TM)
Components
(#1 for UL60 or #72 for UL60 (TM).
#2, #3, #4, #5, #6, #7, #8, #38, #42,
#44, #45, #46, #48, #54, #58)

PARTS LIST — FOR REFERENCE ONLY

Index Number	Part Number	Description	Qty.	Index Number	Part Number	Description	Qty.	Index Number	Part Number	Description	Qty.				
1	143-025-2	Handle	1	32	143-924-6	Metal Tag	1	57	990-337-0	O-Ring (JW1530-27)	2 ■				
2	147-100-3	Valve	1	33	930-205-0	Driver Rivet No.0 x 2.6	2	58	990-912-0	O-Ring (SNS-14)	1				
3	147-104-2	Valve Rod	1	34	944-002-0	Supporting Ring (2.6 x 4.5 x 11)	1 ●	59	990-914-0	O-Ring (SNS-16)	1				
4	147-107-2	Valve Lever	1	35	944-213-0	Supporting Ring (12 x 16 x 1)	1 ●	60	990-916-0	O-Ring (SNS-18)	1				
5	147-210-2	Reverse Valve	1	36	945-935-0	Hexagon Round Head Bolt (M3 x 6)	1	61	990-971-0	O-Ring (SNS-3) (NOK)	1 ●				
6	147-211-2	Reverse Valve Bushing	1	37	945-942-0	Hexagon Round Head Bolt (M4 x 6)	1	62	992-020-0	SU-Ring (Q12) (NTN)	1 ●				
7	480-212-8	Reverse Lever	1	38	952-106-0	Allen Head Dog Point Screw (M4 x 6)	1	63	891-561-1	Anvil (P)	1				
8	147-091-2	Air Inlet Bushing	1	39	961-030-0	Flat Washer (3 mm)	1	63-1	143-319-7	Anvil (O)	1				
9	147-780-3	Exhaust Stack	1	40	970-148-0	Pin (H) (2.5 x 3.8)	1	64	891-300-1	Socket Pin Assembly (3/8)	1				
10	147-042-2	Silencer	1	41	971-102-0	Pin (2 x 3.8)	1	PARTS FOR UL60D							
11	147-835-3	Filter (K200)	1 ■	42	971-123-0	Pin (2 x 23)	1	65	143-350-7	Driver Anvil	1				
12	147-285-2	Rear Plate	1	43	973-008-0	Roll Pin (2 x 8)	2	66	011-351-1	Bit Sleeve (1/8)	1				
13	147-286-2	Cylinder	1	44	973-014-0	Roll Pin (2 x 14)	1	67	011-352-1	Bit Spacer	1				
14	147-287-3	Rotor	1	45	976-006-0	Spring (3 x 5)	1	68	143-924-7	Metal Tag	1				
15	147-288-2	Blade (PC)	9 ■	46	976-457-0	Spring (7 x 12) (0.9)	1	69	976-327-0	Spring (13.5 x 11) (0.9)	1				
16	147-289-3	Front Plate	1	47	976-788-0	Spring (3.5 x 25) (0.45) WPC	2 ●	70	978-117-0	Snap Ring (11.7 x 1.0)	1				
17	147-036-2	Hammer Casing Connector	1	47-1	979-405-0	Outer Snap Ring (E2.5)	1	71	981-002-0	Ball (1/8)	1				
18	143-439-6	Front casing	1	48	981-002-0	Ball (1/8)	1	PARTS FOR (TM)-TYPE							
19	143-243-8	Regulator Valve Cover	1	49	981-045-0	Ball (1.5)	8	72	852-524-1	Handle	1				
20	143-901-6	Rear Liner Plate	1	50	982-014-0	Ball Bearing (607)	1 ■	73	850-610-1	Connecting Screw	1				
21	143-902-6	Liner	1	51	982-902-0	Ball Bearing (6901)	1 ■	74	933-250-0	One-touch Connector (SLS-04)	1				
23	143-440-6	Driving Blade	2	52	982-922-0	Ball Bearing (6901ZZ)	1	75	935-240-0	Nylon Tube (13NY)	1				
24	143-974-6	Roller (2.5 x 25)	2	53	993-100-0	Rubber Sponge Ring (12 x 16.5 x 2)	1	76	935-350-0	Polyurethane Hose (F-1504)	1				
25	143-906-3	Liner Casing Cover	1	54	990-306-0	O-Ring (ARP-568-004) (H)	1	79	852-529-1	Front Plate	1				
26	143-970-6	Relief Valve	1	55	990-320-0	O-Ring (ARP-568-003)	1 ●	ACCESSORIES							
27	136-969-7	Relief Valve Plate	1	56	990-331-0	O-Ring (JW1530-21)	1 ●	77	939-091-0	Allen Wrench (1.5)	1				
28	178-327-0	Anvil Front Spacer	1									78	939-107-0	Allen Wrench (2)	1
29	143-790-3	Suspension Ring	1												
30	147-842-2	Handle Cover	1												
31	143-840-3	Handle Protector	1												



10000 SE PINE
PORTLAND, OR 97216
503-254-6600
FAX 503-255-2615

When ordering spare parts, please specify tool type, part number, and description.

FOOTNOTES

- = Items in Pulse Repair Kit UL-60D-PRK
- = Items in Repair Kit UL-60D-RK

UL-60D-PRK

(Kit contains following parts)

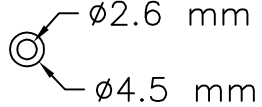
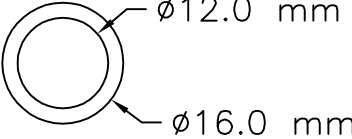
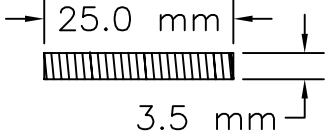
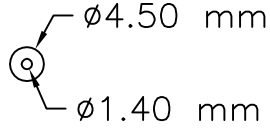
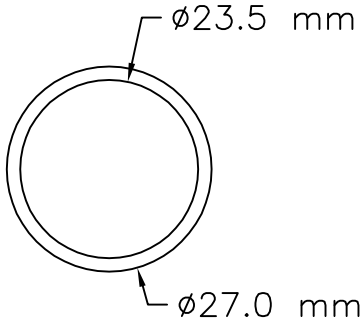
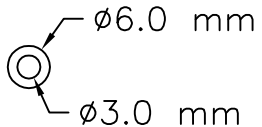
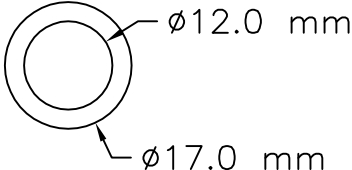
#/#	Bin Location	Part Number	QTY	Description	Material	Drawing / Scketch
1	PA10	944-002-0	1	Support Ring 2.6x4.5x1	Teflon-White	 <p>∅2.6 mm ∅4.5 mm</p>
2	PA10	944-212-0	1	Supporting Ring 12x16x1.5	Teflon-White	 <p>∅12.0 mm ∅16.0 mm</p>
3	PA1J	976-788-0	2	Spring 3.5 X 25	Spring wire ∅.46 mm	 <p>25.0 mm 3.5 mm</p>
4	PA1A	990-320-0	1	O-Ring 4.5X1.4X1.6	Buna-Black	 <p>∅4.50 mm ∅1.40 mm</p>
5	PA1A	990-331-0	1	O-Ring (JW1530-21)	Buna-Black	 <p>∅23.5 mm ∅27.0 mm</p>
6	PA1C	990-971-0	1	O-Ring (SNS-3) (NOK)	Buna-Black	 <p>∅6.0 mm ∅3.0 mm</p>
7	PA1P	992-020-0	1	SU-Ring (Q-12) (NTN)	Buna-Black	 <p>∅12.0 mm ∅17.0 mm</p>

UL-60D-RK

(Kit contains following parts)

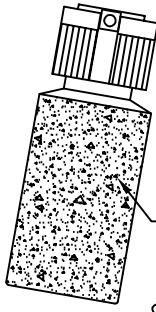
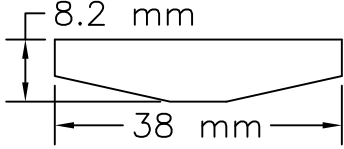
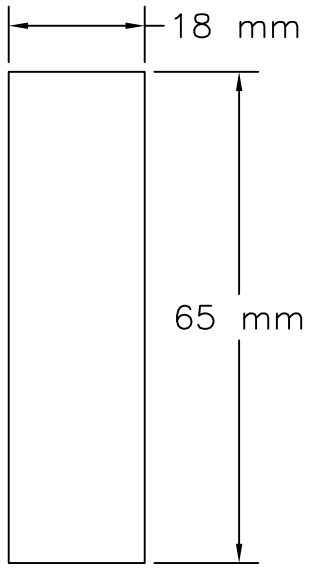
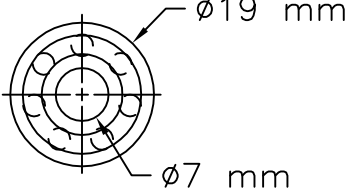
#/#	Bin Location	Part Number	QTY	Description	Material	Drawing / Scketch
1	SEWALL	AM-OIL	1	Oil Air Motor 1 oz. fluid	Plastic Container	 <p style="text-align: right;">Air Oil 1 oz. Scale 1:2</p>
2	PA2B	147-288-2	9	Blade(PC) 8.2x38x1.65	Phenolic-Fiber	
3	PA3A	147-835-3	1	Filter K100 18x65x1.60	Sendered Plastic	
4	PA2H	982-014-0	1	Ball Bearing(607) 7x19x6	Bearing Steel	

UL-60D-RK

(Kit contains following parts)

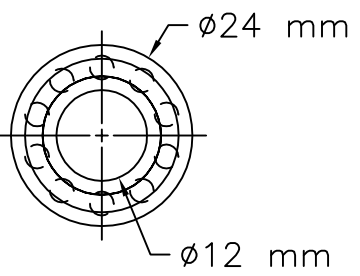
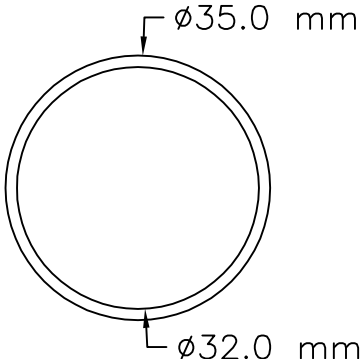
#/#	Bin Location	Part Number	QTY	Description	Material	Drawing / Scketch
5	PA2I	982-902-0	1	Ball Bearing(6901) 12x24x6	Bearing Steel	 <p> $\phi 24$ mm $\phi 12$ mm </p>
6	PA1A	990-337-0	2	O-Ring (JW1530-27) 32x36x1.75	Buna-Black	 <p> $\phi 35.0$ mm $\phi 32.0$ mm </p>

UL-60D-RK

(Kit contains following parts)

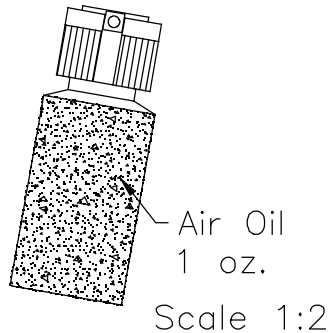
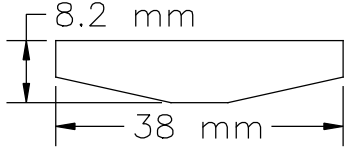
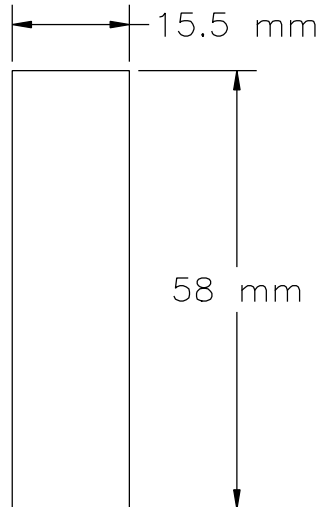
#/#	Bin Location	Part Number	QTY	Description	Material	Drawing / Scketch
1	SEWALL	AM-OIL	1	Oil Air Motor 1 oz. fluid	Plastic Container	
2	PA2B	147-288-2	9	Blade(PC) 8.2x38x1.65	Phenolic-Fiber	
3	PA3A	147-835-3	1	Filter K200 15.5x58x1.65	Sendered Plastic	
4	PA2H	982-014-0	1	Ball Bearing(607) 7x19x6	Bearing Steel	