

# UL-50, UL-50D SERIES OIL-PULSE WRENCHES

## EXPLODED VIEW

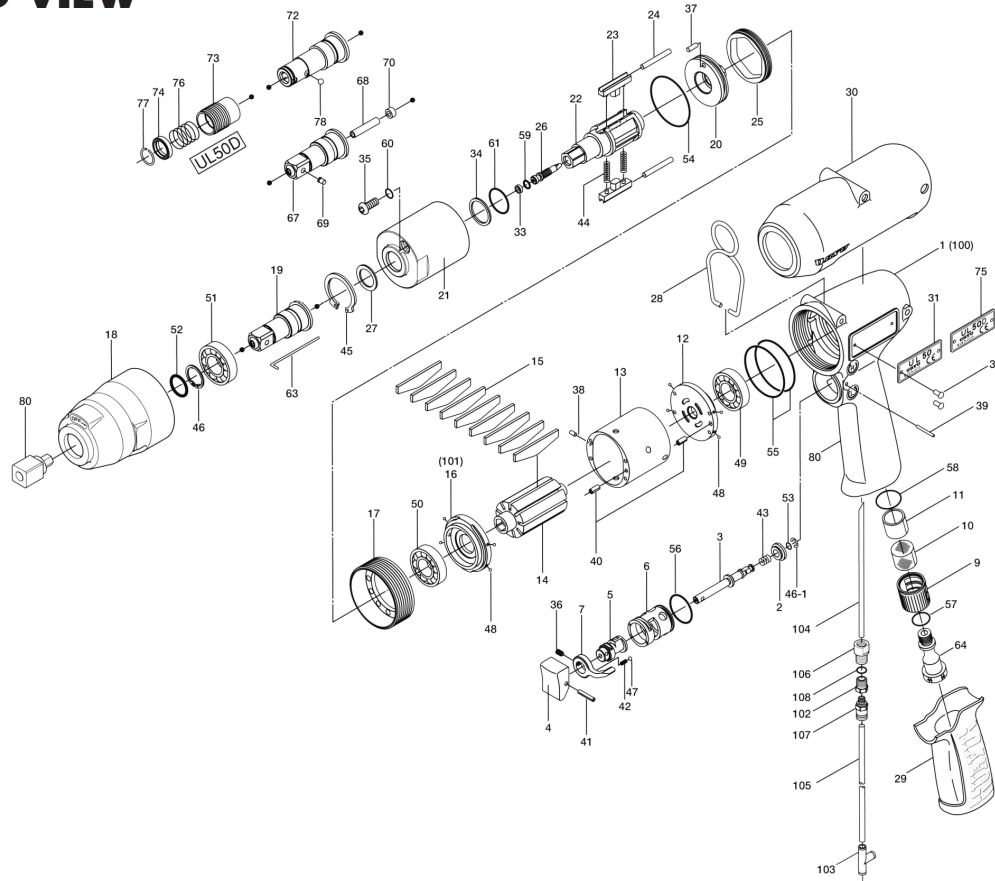

## PARTS LIST — FOR REFERENCE ONLY

Index Number	Part Number	Description	Qty.	Index Number	Part Number	Description	Qty.	Index Number	Part Number	Description	Qty.
1	143-025-4	Handle	1	33	944-002-0	Supporting Ring (2.6 x 4.5 x 1)	1 ●	61	992-020-0	SU-Ring (Q-12) (NTN)	1 ●
2	147-100-3	Valve	1	34	944-212-0	Supporting Ring (12 x 16 x 1.5)	1	67	891-558-1	Socket Spindle Assembly (P)	1
3	147-104-2	Valve Rod	1	35	945-942-0	Hexagon Round Head Bolt (M4 x 6)	1	68	891-559-1	Pipe	1
4	147-107-2	Valve Lever	1	36	952-106-0	Allen Head Dog Point Screw (M4 x 6)	1	69	891-560-1	Socket Snap Pin	1
5	147-210-2	Reverse Valve	1	37	970-148-0	Pin (H) (2.5 x 3.8)	1	70	975-001-0	Spacer (6 x 2.8 x 3)	1
6	147-211-2	Reverse Valve Bushing	1	38	971-102-0	Pin (2 x 3.8)	1	<b>PARTS FOR UL-50D</b>			
7	480-212-8	Reverse Lever	1	39	971-123-0	Pin (2 x 23)	1	72	158-350-6	Driver Anvil	1
64	147-091-2	Air Inlet Bushing	1	40	973-008-0	Roll Pin (2 x 8)	2	73	011-351-1	Bit Sleeve (1/8)	1
9	147-780-3	Exhaust Stack	1	41	973-014-0	Roll Pin (2 x 14)	1	74	011-352-1	Bit Spacer	1
10	147-042-2	Silencer	1	42	976-006-0	Spring (3 x 5) (0.4)	1	75	143-924-5	Name Plate	1
11	145-835-8	Filter (K100)	1 ■	43	976-457-0	Spring (7 x 12) (0.9)	1	76	976-327-0	Spring (13.5 x 11) (0.9)	1
12	147-285-2	Rear Plate	1	44	976-792-0	Spring (3.5 x 21 x 0.45) WPC	2 ●	77	978-117-0	Snap Ring (11.7 x 1.0)	1
13	143-286-3	Cylinder	1	45	979-327-0	Inner Snap Ring (IRTW-28)	1	78	981-002-0	Ball (1/8)	1
14	143-287-3	Rotor	1	46	979-356-0	Inner Snap Ring (ISTW-15)	1	<b>PARTS FOR (TM)-TYPE</b>			
15	143-288-3	Blade (PC)	9 ■	46-1	979-405-0	Outer Snap Ring (E2.5)	1	100	852-523-1	Handle	1
16	147-289-3	Front Plate	1	47	981-002-0	Ball (1/8)	1	101	852-529-1	Front Plate	1
17	147-036-2	Hammer Casing Connector	1	48	981-045-0	Ball (1.5)	8	102	851-955-1	Connecting Screw	1
18	143-439-3	Front Casing	1	49	982-014-0	Ball Bearing (607)	1 ■	103	933-250-0	One-Touch Connector (SLS-04)	1
19	143-454-3	Socket Spindle	1	50	982-902-0	Ball Bearing (6901)	1 ■	104	935-358-0	Hose (TU-0212)	1
20	143-901-3	Rear Liner Plate	1	51	982-923-0	Ball Bearing (6902ZZ)	1	105	935-350-0	Hose (F-1504)	1
21	143-902-3	Liner	1	52	993-102-0	Rubber Sponge Ring (16 x 20.5 x 2)	1	106	851-967-1	Plug	1
22	143-319-4	Anvil	1	53	990-306-0	O-Ring (ARP-568-004) (H)	1	107	933-281-0	One-Touch Connector (K02H04-M5N)	1
23	143-440-3	Driving Blade	2	54	990-331-0	O-Ring (JW1530-21)	1 ●	108	990-320-0	O-Ring (ARPS68-003)	1
24	143-974-3	Roller (2.5 x 22)	2	55	990-337-0	O-Ring (JW1530-27)	2 ■	<b>ACCESSORIES</b>			
25	143-906-3	Liner Casing Cover	1	56	990-912-0	O-Ring (SNS-14)	1	63	939-090-0	Allen Wrench 1.5 (80 x 20)	1
26	143-970-3	Relief Valve	1	57	990-914-0	O-Ring (SNS-16)	1	65	940-114-0	Air Hose Nipple (NPT 1/4 x 3/8)	1
27	178-327-0	Anvil Front Spacer	1	58	990-916-0	O-Ring (SNS-18)	1	79	916-810-0	(+) Double Bit No. 2 x 75 (6.35H)	1
28	143-790-3	Suspension Bail	1	59	990-970-0	O-Ring (SNS-2)	1 ●	80	143-242-2	Regulating Attachment	1
29	147-842-2	Handle Cover	1	60	990-971-0	O-Ring (SNS-3)	1 ●	<b>FOOTNOTES</b>			
30	143-840-3	Casing Protector	1					●	= Items in Pulse Repair Kit UL-50-PRK		
31	143-924-3	Name Plate	1					■	= Items in Repair Kit UL-50-PRK		
32	930-205-0	Screw (No.0 x 2.6)	2								



10000 SE PINE  
PORTLAND, OR 97216  
503-254-6600  
FAX 503-255-2615

When ordering spare parts, please specify tool type, part number, and description.

**FOOTNOTES**  
● = Items in Pulse Repair Kit UL-50-PRK  
■ = Items in Repair Kit UL-50-PRK

# UL-50-PRK

(Kit contains following parts)

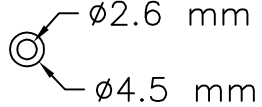
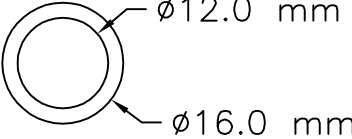
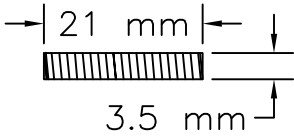
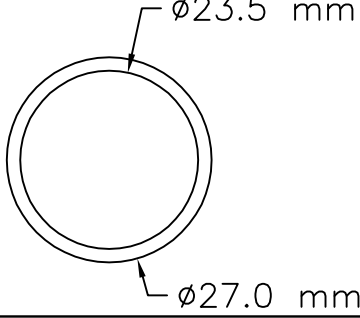
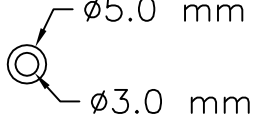
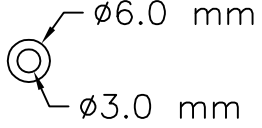
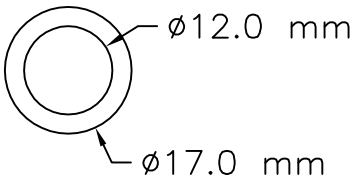
#/#	Bin Location	Part Number	QTY	Description	Material	Drawing / Scketch
1	PA10	944-002-0	1	Support Ring 2.6x4.5x1	Teflon-White	 <p>∅2.6 mm ∅4.5 mm</p>
2	PA10	944-212-0	1	Supporting Ring 12x16x1.5	Teflon-White	 <p>∅12.0 mm ∅16.0 mm</p>
3	PA1J	976-792-0	2	Spring 3.5x21 (0.45)WPC	Spring wire ∅.45 mm	 <p>21 mm ∅.45 mm 3.5 mm</p>
4	PA1A	990-331-0	1	O-Ring (JW1530-21)	Buna-Black	 <p>∅23.5 mm ∅27.0 mm</p>
5	PA1C	990-970-0	1	O-Ring (SNS-2)	Buna-Black	 <p>∅5.0 mm ∅3.0 mm</p>
6	PA1C	990-971-0	1	O-Ring (SNS-3) (NOK)	Buna-Black	 <p>∅6.0 mm ∅3.0 mm</p>
7	PA10	992-020-0	1	SU-Ring (Q-12) (NTN)	Buna-Black	 <p>∅12.0 mm ∅17.0 mm</p>

# UL-50-RK

(Kit contains following parts)

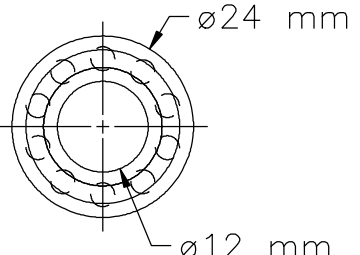
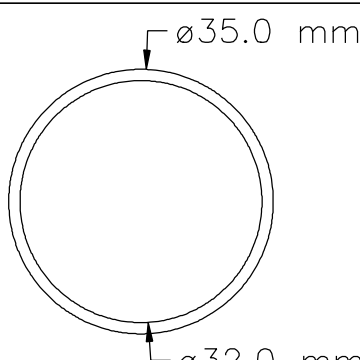
#/#	Bin Location	Part Number	QTY	Description	Material	Drawing / Scketch
5	PA2I	982-902-0	1	Ball Bearing(6901) 12x24x6	Bearing Steel	
6	PA1A	990-337-0	2	O-Ring (JW1530-27) 32x36x1.75	Buna-Black	

# UL-50-RK

(Kit contains following parts)

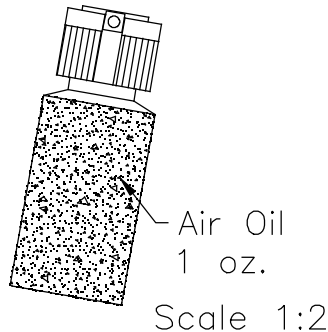
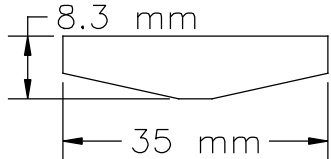
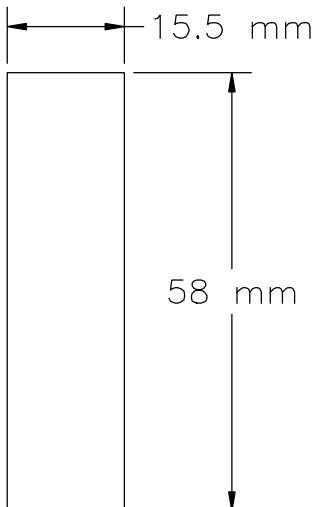
#/#	Bin Location	Part Number	QTY	Description	Material	Drawing / Scketch
1	SEWALL	AM-OIL	1	Oil Air Motor 1 oz. fluid	Plastic Container	
2	PA2B	143-288-3	9	Blade(PC) 8.3x35x1.65	Phenolic-Fiber	
3	PA3A	145-835-8	1	Filter K100 15.5x58x1.50	Sendered Plastic	
4	PA2H	982-014-0	1	Ball Bearing(607) 7x19x6	Bearing Steel	