

UL-30, UL-30D SERIES OIL PULSE WRENCHES

EXPLODED VIEW

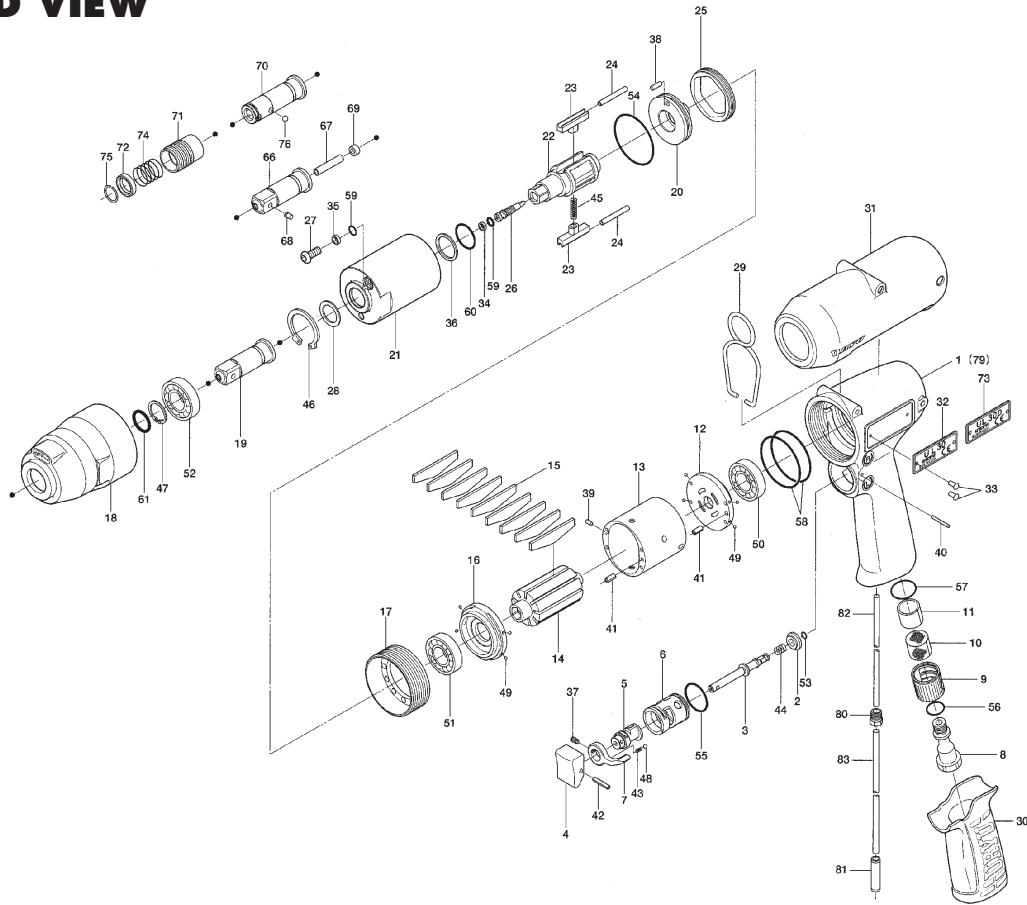

PARTS LIST — FOR REFERENCE ONLY

Index Number	Part Number	Description	Qty.	Index Number	Part Number	Description	Qty.	Index Number	Part Number	Description	Qty.
1	143-025-0	Handle	1	30	147-842-2	Handle Cover	1	58	990-925-0	O-Ring (SNS-32)	2 ■
2	147-100-3	Valve	1	31	143-840-0	Casing Protector	1	59	990-970-0	O-Ring (SNS-2)NOK	2 ●
3	147-104-2	Valve Rod	1	32	142-924-8	Name Plate	1	60	992-019-0	SU-Ring (Q10) (NTN)	1 ●
4	147-107-2	Valve Lever	1	33	930-205-0	Driver Rivet No. (0 x 2.6)	2	61	993-100-0	Rubber Sponge Ring (12 x 16.5 x 2)	1
5	147-210-2	Reverse Valve	1	34	944-002-0	Supporting Ring (2.6 x 4.5 x 1)	1 ●	66	891-565-1	Socket Spindle Assembly (P)	1
6	147-211-2	Reverse Valve Bushing	1	35	944-003-0	Supporting Ring (3 x 5 x 1)	1 ●	67	891-559-1	Pipe	1
7	480-212-8	Reverse Lever	1	36	944-234-0	Supporting Ring (10 x 14 x 1.5)	1 ●	68	891-560-1	Socket Snap Pin	1
8	142-091-8	Air Inlet Bushing	1	37	952-106-0	Allen Head Dog Point Screw (M4 x 6)	1	69	975-001-0	Spacer (6 x 2.8 x 3)	1
9	147-780-3	Exhaust Stack	1	38	970-148-0	Pin (H) (2.5 x 3.8)	1	PARTS FOR UL-30D			
10	147-042-2	Silencer	1	39	971-102-0	Pin (2 x 3.8)	1	70	143-350-2	Driver Anvil	1
11	145-835-8	Filter (K100)	1 ■	40	971-123-0	Pin (2 x 23)	1	71	011-351-1	Bit Sleeve (1/8)	1
12	143-285-0	Rear Plate	1	41	973-008-0	Roll Pin (2 x 8)	2	72	011-352-1	Bit Spacer	1
13	143-286-0	Cylinder	1	42	973-014-0	Roll Pin (2 x 14)	1	73	142-924-9	Name Plate	1
14	143-287-0	Rotor	1	43	976-006-0	Spring (3 x 5) (0.4)	1	74	976-327-0	Spring (13.5 x 11) (0.9)	1
15	143-288-0	Blade (PC)	9 ■	44	976-457-0	Spring (7 x 12) (0.9)	1	75	978-117-0	Snap Ring (11.7 x 1.0)	1
16	144-289-0	Front Plate	1	45	976-803-0	Spring (2.8 x 18) (0.4)WPC	1 ●	76	981-002-0	Ball (1/8)	1
17	143-036-0	Hammer Casing Connector	1	46	979-324-0	Inner Snap Ring (IRTW-24)	1	PARTS FOR (TM) TYPE			
18	143-439-0	Front Casing	1	47	979-353-0	Inner Snap Ring (ISTW-12)	1	79	851-073-1	Handle	1
19	143-454-0	Socket Spindle	1	48	981-002-0	Ball (1/8)	1	80	850-610-1	Connecting Screw	1
20	143-901-0	Liner Rear Plate	1	49	981-045-0	Ball (1.5)	8	81	933-250-0	One Touch Connector (SLS-04)	1
21	142-902-8	Liner	1	50	982-014-0	Ball Bearing (607)	1 ■	82	935-240-0	Nylon Tube (18NY)	1
22	143-319-2	Anvil	1	51	982-901-0	Ball Bearing (6900)	1 ■	83	935-350-0	Polyurethane Hose (F1504)	1
23	143-440-0	Driving Blade	2	52	982-922-0	Ball Bearing (6901ZZ)	1	ACCESSORIES			
24	143-974-0	Roller (2.5 x 21)	2	53	990-306-0	O-Ring (ARP-568-004) (H)	1	84	143-242-2	Adjuster	1
25	143-906-0	Liner Casing Setter	1	54	990-329-0	O-Ring (JW1530-19)	1 ●	85	939-091-0	Allen Wrench (1.5 mm) (55 x 55)	1
26	143-970-3	Relief Valve	1	55	990-912-0	O-Ring (SNS-14)	1				
27	194-742-3	Oil Plug	1	56	990-914-0	O-Ring (SNS-16)	1				
28	143-327-1	Anvil Front Spacer	1	57	990-916-0	O-Ring (SNS-18)	1				
29	143-790-3	Suspension Ring	1								



10000 SE PINE
PORTLAND, OR 97216
503-254-6600
FAX 503-255-2615

When ordering spare parts, please specify
tool type, part number, and description.

FOOTNOTES

- = Items in Pulse Repair Kit UL-30-PRK
- = Items in Repair Kit UL-30RK

UL-30D-PRK

(Kit contains following parts)

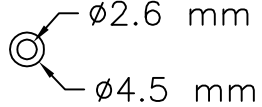
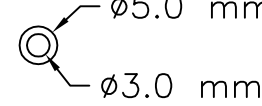
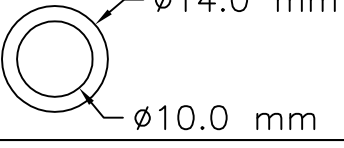
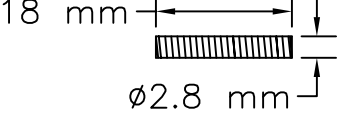
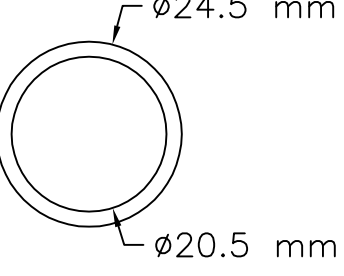
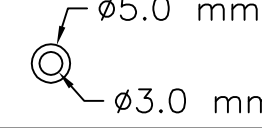
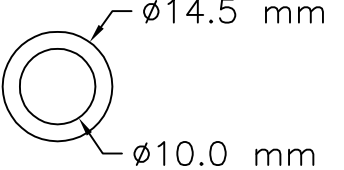
#/#	Bin Location	Part Number	QTY	Description	Material	Drawing / Scketch
1	PA10	944-002-0	1	Support Ring 2.6x4.5x1	Teflon-White	 <p>∅2.6 mm ∅4.5 mm</p>
2	PA10	944-003-0	1	Support Ring 3.0x5.0x1	Teflon-White	 <p>∅5.0 mm ∅3.0 mm</p>
3	PA10	944-211-0	1	Supporting Ring 10x14x1.5	Teflon-White	 <p>∅14.0 mm ∅10.0 mm</p>
4	PA1J	976-803-0	1	Spring 2.8x18	Spring wire ∅.40 mm	 <p>18 mm ∅2.8 mm</p>
5	PA1A	990-329-0	1	O-Ring 24.5X20.5X1.8	Buna-Black	 <p>∅24.5 mm ∅20.5 mm</p>
6	PA1C	990-970-0	2	O-Ring (SNS-2)	Buna-Black	 <p>∅5.0 mm ∅3.0 mm</p>
7	OR38A6	992-019-0	1	SU-Ring (Q-10) (NTN)	Buna-Black	 <p>∅14.5 mm ∅10.0 mm</p>

UL-30D-RK

(Kit contains following parts)

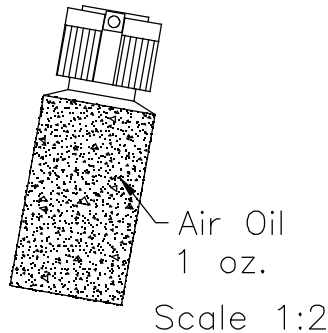
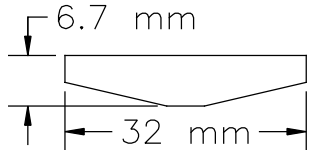
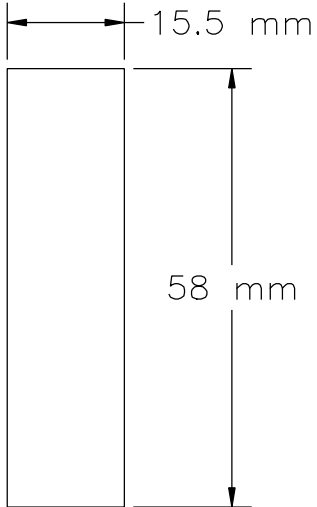
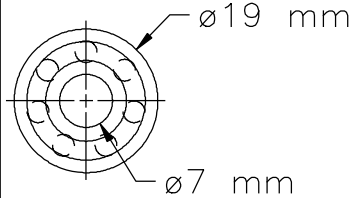
#/#	Bin Location	Part Number	QTY	Description	Material	Drawing / Scketch
1	SEWALL	AM-OIL	1	Oil Air Motor 1 oz. fluid	Plastic Container	 <p>Air Oil 1 oz. Scale 1:2</p>
2	PA2A	143-288-0	9	Blade(PC) 6.7x32x1.36	Phenolic-Fiber	 <p>6.7 mm 32 mm</p>
3	PA3A	145-835-8	1	Filter K100 15.5x58x1.50	Sendered Plastic	 <p>15.5 mm 58 mm</p>
4	PA2H	982-014-0	1	Ball Bearing(607) 7x19x6	Bearing Steel	 <p>ø19 mm ø7 mm</p>

UL-30D-RK

(Kit contains following parts)

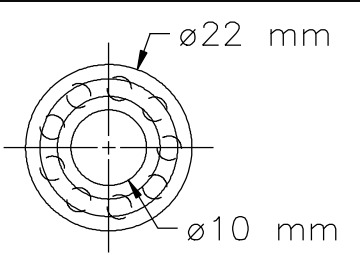
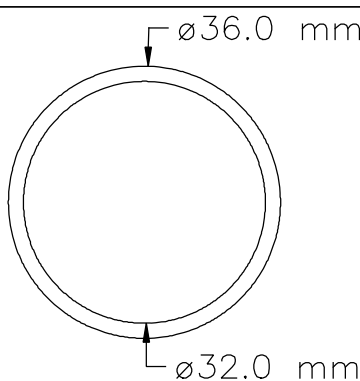
#/#	Bin Location	Part Number	QTY	Description	Material	Drawing / Scketch
5	PA2I	982-901-0	1	Ball Bearing(6900) 10x22x6	Bearing Steel	 <p>A technical drawing showing a cross-section of a ball bearing. The outer diameter is labeled as $\varnothing 22$ mm and the inner diameter is labeled as $\varnothing 10$ mm. The drawing shows the outer ring, inner ring, and several balls in between.</p>
6	PA1B	990-925-0	2	O-Ring (SNS-32) 32x36x2	Buna-Black	 <p>A technical drawing of an O-ring. The outer diameter is labeled as $\varnothing 36.0$ mm and the inner diameter is labeled as $\varnothing 32.0$ mm. The drawing shows a circular cross-section of the ring.</p>