

TW-3 & TW-5 SPRING BALANCERS

EXPLODED VIEW

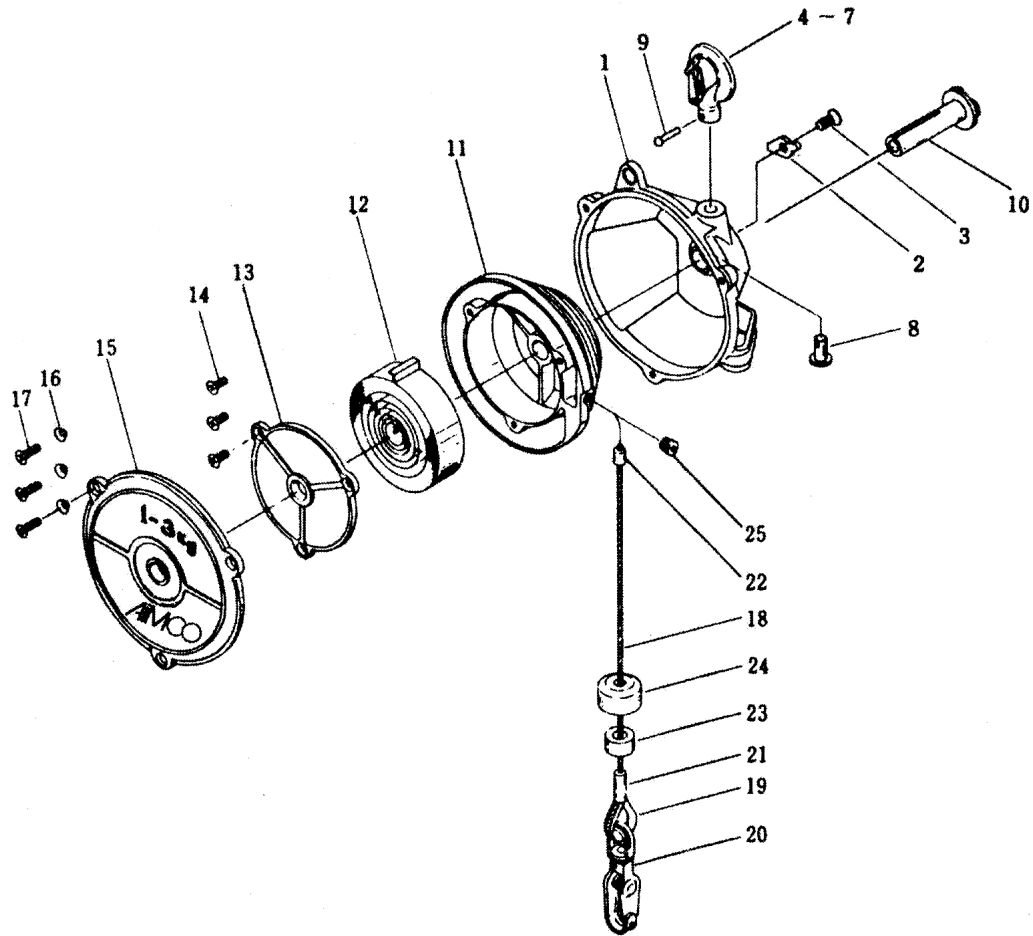

PARTS LIST — FOR REFERENCE ONLY

Index Number	Part Number	Description	Qty.	Index Number	Part Number	Description	Qty.	Index Number	Part Number	Description	Qty.
1	3001-1A	Case Assembly	1		5009-12A	Spiral Spring for TW-5	1	23	3016-23	Collar	1
2		Ratchet	1	13	3010-13A	Drum Cover	1	24	3017-24	Shock Absorber	1
3		F H Screw	1	14	SC512	F H Screw	1	25	PH1/8	Cable Set Bolt	1
Hanger Set:				15	3002-15A	Cover for TW-3	1				
4		Hanger	1		5012	Cover for TW-5	1				
5		Hanger Stopper	1	16	WT5	Lock Washer	1				
6		Hanger Spring	1	17	SC516	FH Screw	1				
7		Button Head Rivet	1	Cable Set							
8	3005-8	Hanger Shaft	1	18		Cable	1				
9	RR318	BH Rivet -1	1	19		Thimble	1				
10	3007-10A	Spindle	1	20		Spring Hook	1				
11	3008-11A	Drum	1	21		Safe-Lock Tube	1				
12	3009-12A	Spiral Spring for TW-3	1	22		Aluminum Lock Tube	1				

FOOTNOTES



10000 SE PINE
 PORTLAND, OR 97216
 503-254-6600
 FAX 503-255-2615

When ordering spare parts, please specify
 tool type, part number, and description.