

ATM-2800 DYNATORQUE MANUAL TORQUE MULTIPLIER

EXPLODED VIEW

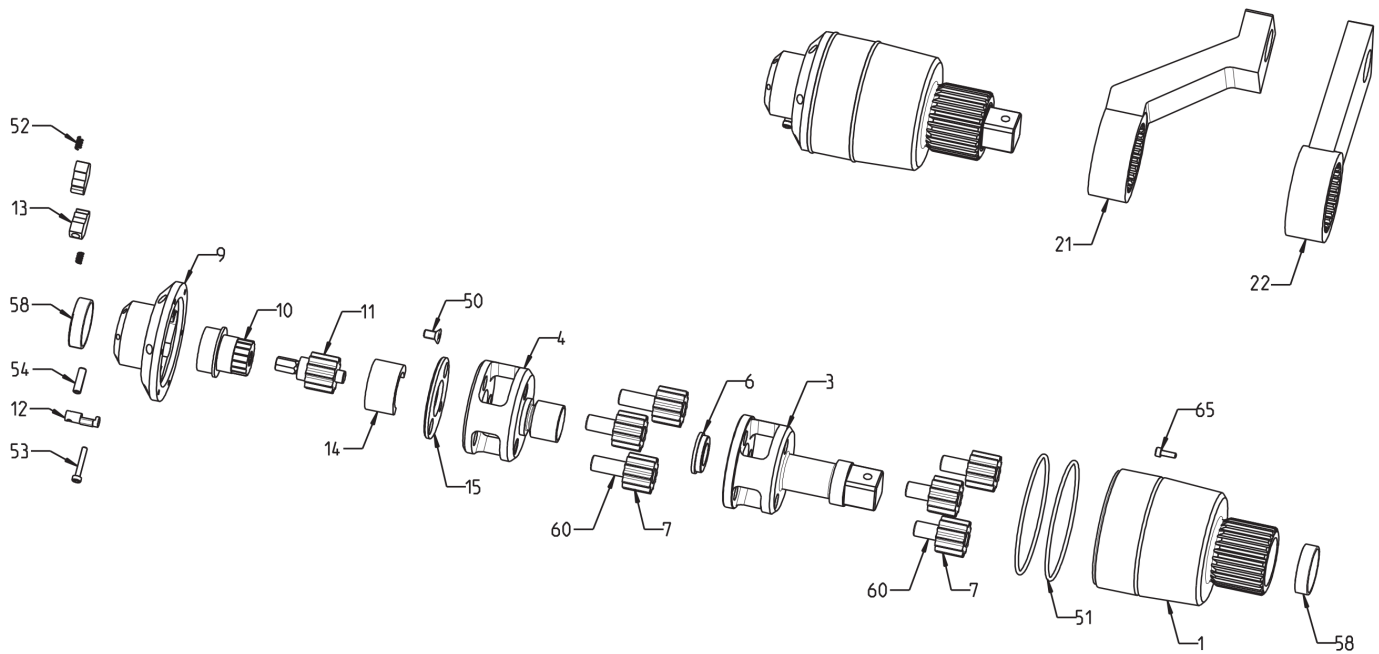

PARTS LIST — FOR REFERENCE ONLY

Index Number	Part Number	Description	Qty.	Index Number	Part Number	Description	Qty.	Index Number	Part Number	Description	Qty.
1	025010028001	Gear Housing	1	12	025502008040	Switch Lever	1	58	659000353910	Bearing 353910	1
3	025010018003	Gear Cage with 1" Sq. Dr.	1	13	025502010640	Switch Bolster	1	60	652163251240	Needle Roller	1
4	025510020004	Cage with SR-12	1	14	025502065640	Distance Disk	1	65	650009120413	Cover Screw	1
6	025510020006	Bearing Sleeve	1	15	025502066640	Slaving Disk	1	ACCESSORIES			
7	025510013007	Planet Gear - 2K	1	50	650079910612	Countersunk Screw	1	21	31318	Angled Reaction Bar	1
9	025010028009	Cover	1	51	654000007003	Rubber Ring	1	22	31319	Straight Reaction Bar	1
10	025510020010	Drive Head - 1/2"	1	52	656000000625	Switch Spring	1				
11	025010028011	Shear Pin - 9K	1	53	650009120425	Switch Lever Screw	1				
				54	652314810620	Clamping Sleeve	1				



10000 SE PINE
 PORTLAND, OR 97216
 503-254-6600
 FAX 503-255-2615

When ordering spare parts, please specify tool type, part number, and description.

FOOTNOTES