

# ATM-12000 DYNATORQUE MANUAL TORQUE MULTIPLIER

## EXPLODED VIEW

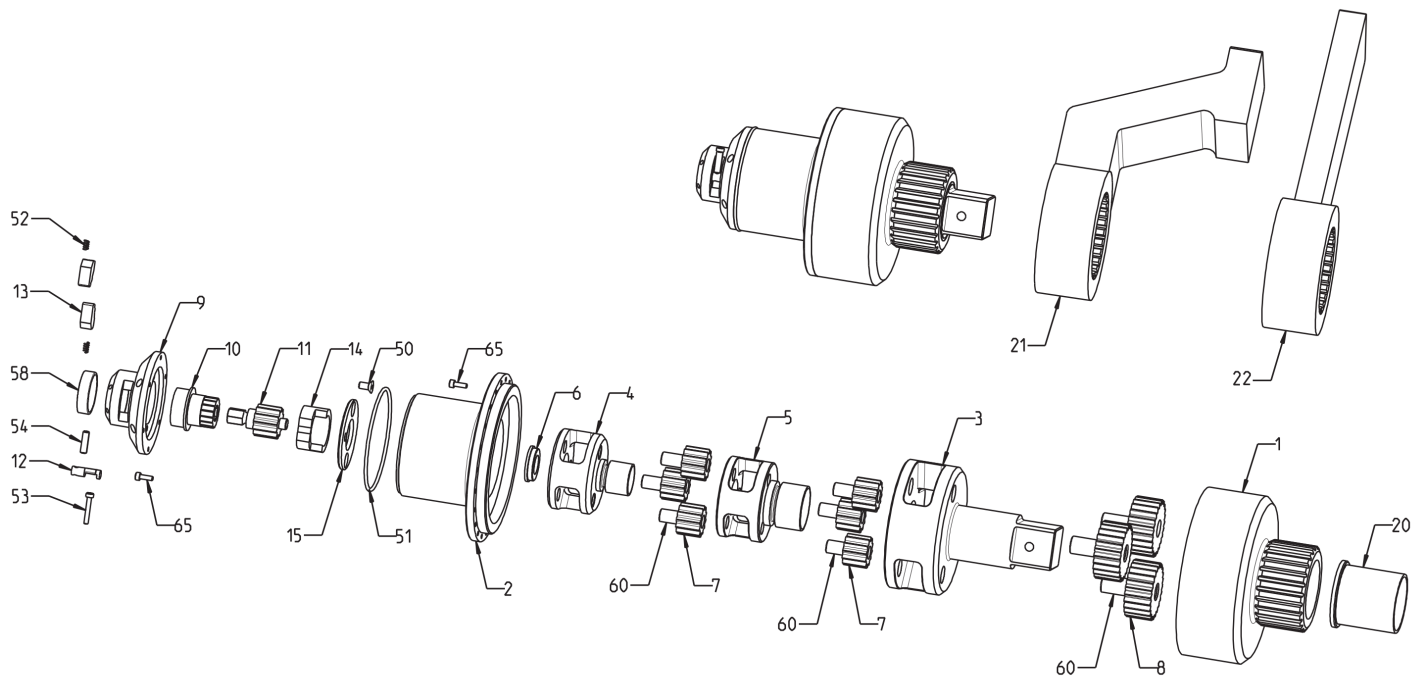

### PARTS LIST — FOR REFERENCE ONLY

Index Number	Part Number	Description	Qty.	Index Number	Part Number	Description	Qty.	Index Number	Part Number	Description	Qty.
1	025010120001	Gear Housing	1	10	025510030010	Drive Head - 3/4"	1	53	650009120425	Switch Lever Screw	1
2	025010120002	Intermediate Gear Housing	1	11	025010120011	Shear Pin - 12K	1	54	652314810620	Clamping Sleeve	1
3	025010120003	Gear Cage with 1.5" Sq. Dr.	1	12	025502008040	Switch Lever	1	58	659000353910	Bearing 333910	1
4	025510020004	Cage with SR-12	1	13	025502010640	Switch Bolster	1	60	652163251240	Needle Roller	1
5	025010080005	Cage with SR-18	1	14	025502065640	Distance Disk	1	65	650009120413	Cover Screw	1
6	025510020006	Bearing Sleeve	1	15	025502066640	Slaving Disk	1	<b>ACCESSORIES</b>			
7	025510013007	Planet Gear -2K	1	20	025010080020	Bearing Bush	1	21	31318	Angled Reaction Bar	1
8	025010120008	Planet Gear - 6K	1	50	650079910612	Countersunk Screw	1	22	31319	Straight Reaction Bar	1
9	025010028009	Cover	1	51	654000007003	Rubber Ring	1				
				52	656000000625	Switch Spring	1				



10000 SE PINE  
 PORTLAND, OR 97216  
 503-254-6600  
 FAX 503-255-2615

When ordering spare parts, please specify tool type, part number, and description.

#### FOOTNOTES