



UX-T, UXR-T and ALPHA-T Series Pulse Unit Repair Manual

Contents

	<u>Page Number</u>
1. Recommended Tools	1
2. Pulse Unit Repair Jigs	2-4
3. Disassembly and Reassembly of the Pulse Unit	5-9
4. Fill, Draw & Torque Sheet	10-12
5. Exploded View of the Pulse Unit	13
6. Recommended Maintenance	14

Recommend Tools

1. One Set T-handle Metric Allen Wrenches
2. Flat-Bladed Screwdrivers
3. 10 oz. Ball Peen Hammer
4. One Set Pin Punches
5. One Set O-Ring Picks
6. 6" Adjustable End Wrench
7. 12" Adjustable End Wrench
8. Medium Pair of Channel Locks or Adjustable Jaw Pliers
9. Medium Honing Stone
10. 220 Grit Wet/Dry Sandpaper
11. Lap Plate
12. Loc-Tite #242
13. Arbor Press
14. VC-101-2A Vacuum Tank
15. VCE-1-1 Vacuum Extractor
16. 1cc and 3cc Glass Syringe
17. CFC Free Degreaser/Cleanser
18. Loc-Tite Accelerator
19. Large Needle for Syringe
20. Two Torque Wrenches: 0-200 ft. lbs. and 50-600 ft. lbs.
21. Universal Repair Fixture
22. Pulstar Pulse Unit Fluid
23. O-Ring Installation Tools
24. Setting in of Torque Adjuster
25. Auditor Series Monitor and Transducers with the UFT Joint Simulators
26. Needle Nose Pliers
27. Propane Torch

Pulse Unit Repair Jigs

Jig for Setting Teflon Seal

Part Number	Tools Jig is Used With			
178-319-8-1 995-512-0-1	UX-450 UX-622	UX-500 ALPHA-50	UX-612 ALPHA-60	
178-350-9-2 995-512-0-1	UX-450D UX-622D	UX-500D ALPHA-50D	UX-612D ALPHA-60D	
194-319-3-1	UX-T900	UX-T1000	UX-T1300	ALPHA-90
199-319-6-1	UX-T1620			
995-500-0-1	UXR-T2000			

Jig for Holding & Pressing in the Accumulator

Part Number	Tools Jig is Used With			
150-972-5-1	ALPHA-T47	ALPHA -T52	UBP-7	UBP-T7

Jig for Disassembly & Assembly of Casing Connector

Part Number	Tools Jig is Used With			
196-294-6-5	U-310SD			
192-035-4-5	U-350D	U-350SD		
177-036-6-5	UX-450 ALPHA -60	UX-500 ALPHA -T45	UX-612 ALPHA-T50	ALPHA-50

Jig for Setting Torque Adjuster

Part Number	Tools Jig is Used With			
195-907-3-1	UX-1000	UX-1300	UX-1400	UX-1620

Vacuum Filler Tank

Part Number	Tools Jig is Used With
VC-101-2A	All Models

Pulse Unit Repair Jigs (cont.)

Glass Syringe

Part Number	Tools Jig is Used With
188-902-0-2 (1cc)	All Models
915-176-0 (3cc)	All Models
195-179-0 (Needle)	All Models

Pulse Unit Fluid

Part Number	Tools Used With
PULSTAR	All Models except ALPHA-T45, T50 and UBP-7 Series
SPF-Oil	ALPHA-T45, T50 and UBP-7 Series only

Jig Set-In O-Ring

Part Number	Tools Used With			
990-319-0-1	U-310SD	U-350D	U-350SD	
990-320-0-1	UX-500 UX-900	UX-602 UX-612	UX-620 UX-622	UX-800
990-320-2-1	UX-700			
990-971-0-1	UXR-1000 UXR-1820	UX-1300	UX-1400	UX-1620
990-972-0-1	UXR-2000	UXR-2000S	UXR-2400S	UXR-3000S

Pulse Unit Repair Jigs (cont.)

Jig For Placing Anvil C/W Driving Blades Into Liner

Part Number	Tools Used With			
190-440-6-1 190-440-6-0	UX-500 UX-622	UX-602	UX-612	UX-620
194-440-2-1 194-440-2-0	UX-700	UX-800	UX-T700	UX-T800
194-440-3-1 194-440-3-0	UX-900	UX-T900		
194-440-6-1 194-440-6-0	UX-1000	UX-1300	UX-T1000	UX-T1300
195-440-6-1 195-440-6-0	UX-1400	UX-1620	UX-T1400	UX-T1620
195-440-9-1 195-440-9-0	UXR-1820	UXR-T1820		
194-440-8-1 194-440-8-0	UXR-2000	UXR-T2000		
176-440-5-1 176-440-5-0	UXR-2400S	UXR-T2400S		
175-440-2-1 175-440-2-0	UXR-3000S	UXR-T3000S		

Universal Pulse Unit Repair Fixture

Part Number	Tools Used With
PTRF-1-1	All Models

Vacuum Extractor

Part Number	Tools Used With
VCE-1-1	All Models

Disassembly and Reassembly of the Pulse Unit

UX-T, UXR-T & Alpha-T Series

A. Disassembly/Reassembly of Pulse Unit

1. Remove the front casing from the tool.
2. Remove the Oil Fill Plug and vacuum the oil out of the Pulse Unit with the VCE-1-1 Vacuum Extractor.
3. Set the Liner Casing Setter, located at the rear of the Pulse Unit, onto the correct size pins in the blocks of the setter. **Note:** This is a left-hand thread.
4. Place Pulse Unit assembly onto the correct size base plate and between the clamp plates of the PTRF-1-1. Run the press rod down into the setter and secure it with the lock nut; it is not necessary to put any pressure on the press rod. Tighten the clamp screws securing the Pulse Unit.
5. Set a 1/2" breaker bar into the setter; this is a left-handed thread indicated by an arrow on the Liner Casing Setter.
6. Loosen and remove the Liner Casing Setter. Remove the Pulse Unit from the repair fixture.
7. Remove the Rear Liner Plate.
 - a) If suction is too great, tap the drive end of the Anvil on bench and loosen Rear Liner Plate.
 - b) Properly discard the oil in the Pulse Unit.
 - c) In the UX-T series, remove the Spring and Ball under the Relief Valve.
 - d) Remove the Piston from the Rear Liner Plate on the UX-T series.
 - e) Remove the Rollers from the Anvil on the UXR-T series.
8. Rotate the Anvil until the bevel lines of the Anvil are parallel with the contacting lines inside the Liner. Push the Anvil out of the Liner to remove the Anvil, Driving Blades, and Springs from assembly.
9. Remove the Front Liner Plate and Liner from the Liner Casing. **Note:** Always remove these two at the same time or the Front Liner Plate may become lodged in the Liner Casing.
10. On the UX-T and ALPHA-T series, remove the Front Liner Plate from the Liner. Using a small screwdriver, pry between the Torque Adjuster and the Pin in the Liner to separate the Front Liner Plate from the Liner.
 - a) Remove the two Locator Pins in the front of the Liner.
 - b) On the ALPHA-T80, remove the snap ring in the front of the Front Liner Plate; on the UX-T1620, remove the Snap Ring in the front of the Front Liner Plate by locating a small opening by the Oil Filler Plug. Remove the Spacer, Supporter Ring, and Teflon seal.
11. On both the UX-T and ALPHA-T series, remove the Torque Adjuster from the Liner by turning clockwise. Now remove the Pin that holds the Relief Valve in the Liner and push the Relief Valve out the back of the Liner.
12. Remove all O-rings and Supporter Rings from the parts. Remove the Anvil, O-ring or Teflon seal and Supporter ring located inside the Front Liner Plate.

Disassembly and Reassembly of the Pulse Unit (cont.)

B. Inspection

1. **Front Liner Plate**

- a) If light scarring on plate surface is present, resurface on Lap Plate in a figure eight motion with 220 grit sandpaper (wet or dry) using honing oil as a buffer. **Note:** All markings must be removed.
- b) If heavy scars or burring are present and cannot be resurfaced smooth, replace parts as needed.

2. **Rear Liner Plate**

- a) If light scarring is present, resurface plate on lap in the same manner as above. **Note:** All markings must be removed.
- b) Check the connecting hex for wear. If rounded out, replace and inspect the female hex of the rotor in the same manner.
- c) If heavy scarring or burrs are present on the plate surface and cannot be resurfaced on Lap Plate, replace parts as needed.

3. **Liner Casing Setter**

- a) Wire wheel outer threads to remove old Loc-tite.
- b) Resurface bottom setting surface (level) using Lap Plate and 220 grit sandpaper.

4. **Driving Blades**

- a) Check the contour surface of the blades for scars or burring.
- b) If driving blade is scarred below the contour surface, fluid will pass underneath the blade at contact points, resulting in inaccurate pressure in the liner and low torque output.
- c) If there is heavy scarring (cuts below contour surface) replace it.
- d) Light scarring on contour surface is normal wear. Clean surface on Lap Plate by lapping the length of the blade and rolling with the contour.
- e) Light horizontal grooves on the side of the blade is normal wear.
- f) Check plate ends of the blade for grooving. If heavy grooving, always replace the blades as a set.

5. **Liner**

- a) Inspect inner horizontal and vertical blade seats for scars and burring.
 1. Light scarring is normal wear.
 2. Heavy scars will cause the fluid to pass by the driving blade, liner will not produce accurate pressure for torque output. Replace.

Disassembly and Reassembly of the Pulse Unit (cont.)

6. **Torque Adjuster/Relief Valve**

- a) Check the adjuster for straightness; also check Allen end for cracking, damaged, or stripped threads. If damage is present, replace.
- b) Check the Ball seat for oblonging.

7. **Liner Casing**

- a) Check for internal scars and burring.
- b) Check internal threads for burrs.

8. **Anvil**

- a) Check plate surface of Anvil. If light scarring or uneven wear is present, resurface with medium oil stone using honing oil as a buffer.
 - b) If heavy scarring is present and cannot be resurfaced smooth, replace Anvil.
 - c) If chips or cracking is present, replace Anvil.
 - d) If uneven wear from socket is present, replace Anvil.
 - e) Check anvil at contact point with O-ring in front liner plate. If there is an indentation present on anvil at this point, anvil should be replaced.
 - f) Check anvil for scarring from anvil bushing. If heavy scarring is present, replace Anvil.
9. Thoroughly clean all parts and blow dry.
10. Replace all O-rings, Springs, Supporter Rings, and Teflon seals. This can be easily done by purchasing a Pulse Unit Repair Kit.

C. Reassembly

1. Using blow gun, clean parts of any remaining solvent or lint.
2. Install the Teflon Seal and Supporter Ring on the UX-T and UXR-T and the O-ring and Supporter Ring on the ALPHA-T.
 - a) UX-T and UXR-T series have a Teflon seal. Slide skirt down onto Anvil. On the UX-T1620, the Teflon seal and Supporter Ring go into the front of the Front Liner Plate. Reinstall the Spacer and Snap Ring into the Front Liner Plate on the UX-T1620. On the UXR-T2000, install the Supporter Ring and Teflon seal into the Front Liner Plate, NOT onto the Anvil.
 - b) On the ALPHA-T80, install the O-Ring and the Supporter Ring into the front of the Front Liner Plate. Install the Spacer and Snap Ring into the Front Liner Plate.
3. Install the O-ring onto Relief Valve and install Relief Valve through the back of the Liner, lining up the slot in the Relief Valve with the Pin Hole in the Liner. Install Pin and Torque Adjuster into Relief Valve.

Disassembly and Reassembly of the Pulse Unit (cont.)

4. Install the Locator Pins into the Liner and install the Torque Adjuster O-ring onto Torque Adjuster and the Supporter Ring into the Front Liner Plate. Install Front Plate onto the Liner.
5. Install Driving Blades and Springs into Anvil. Place in Driving Blade Setter.
6. Install Anvil and Driving Blades into Liner.
7. Install the Ball and Spring into back of Relief Valve. On the UXR-T series, slide Rollers into Anvil.
8. Install the Piston with new O-ring. Cap end to the inside of unit into the Rear Liner Plate. Install Locator Pins in rear of Liner and assemble Rear Liner Plate. **Note:** Make sure that the Spring goes into the Rear Liner Plate.
9. Install Rear Plate O-ring.
10. Place the hex end of the Rear Liner Plate into vise with soft jaws. The drive end of the Anvil should be up.
11. Install O-ring onto Front Plate.
12. Put a light amount of Pulse Fluid into the Liner Casing, align the Liner Casing with the Guide Pins and the Torque Adjuster openings, and slide the Liner Casing downward until the Liner Casing is flush with the Liner.
13. Clean all oils from the threads of Liner Setter and Liner Casing. Lightly coat the threads with a good cleaner/degreaser. Put a light coat of a good quality thread locker on the threads of the Liner setter and thread it into the Liner Casing.
14. Place the Press Rod Cap into the Setter and set the Liner Casing Setter, located at the rear of the Pulse Unit onto the correct size pins in the blocks of the setter. **Note:** This is left-hand thread.
15. Place Pulse Unit assembly onto the correct size base plate and between the clamp plates. Run the press rod down into the setter and secure it with the lock nut. Torque the Press Rod to the recommended tonnage for the Pulse Unit being worked on. **Note:** See chart for the proper tonnage. Tighten the clamp screws securing the Pulse Unit.
16. Set a 1/2" torque wrench into the Setter and tighten the Liner Setter to the recommended torque shown on the chart.
17. Remove the Pulse Unit from the repair fixture.

D. Fluid

1. Recommended fluid is AIM/Uryu Pulse Unit Fluid part number Pulstar.

E. Hand and Vacuum Tank Filling Procedure

1. Place the Pulse Unit, Anvil upward, into bench vise.
2. Check the freeness of the Torque Adjuster, then back off completely, counter-clockwise, and remove Oil Filler Plug.
3. Rotate the Anvil until the Driving Blade is visible in the Oil Filler Opening, then turn the Anvil 1/8th of a turn. This places the Driving Blades at an open position.

Disassembly and Reassembly of the Pulse Unit (cont.)

4. The Pulse Unit is now set for maximum fill. Any measurable change in fluid level will affect the torque output and the consistency of the tool.
5. Put the Pulse Unit in Vacuum Tank to purge all air out of the Pulse Unit, proceed to step 13. If you do not have a vacuum tank, proceed to step 6.
6. Fill the 3cc Syringe with fluid. Turn Syringe upside-down and push plunger to purge all air from the Syringe.
7. Insert the Needle on the Syringe and insert it into the Oil fill hole. Fill the Pulse Unit completely with fluid from the bottom up, **slowly**.
8. Fill 3cc Syringe with fluid and again purge all air bubbles.
9. Turn the Anvil clockwise only to purge the air from Pulse Unit. As air bubbles appear, over-fill unit with 3cc Syringe and continue to turn the Anvil clockwise. Go slowly by seal point to prevent air from sucking back into the Pulse Unit.
10. When no bubbles are present, Pulse Unit is air free.
11. Install Oil Fill Plug and cycle Pulse Unit two to three times. This will push fluid down under the Relief Valve. Remove Oil Filler Plug and purge for air.
12. Rotate Anvil until Driving Blade is again visible in Oil Filler Opening and turn Blade 1/8 of a turn from opening.
13. Fill 3cc Syringe with 1cc of fluid for accurate drawing of fluid.
14. Wipe off excess fluid from top of the unit. Oil level should be at the top of the Oil Filler Plug Threads before drawing.
15. Using the 3cc Syringe, draw out the specified amount of fluid per specifications for each model (see chart).
16. Thread Oil Filler Plug into hole and tighten.
17. You are now ready to test the Pulse Unit.

F. Torque Adjustment

1. To properly adjust the torque, turn the Adjuster with proper size Allen wrench clockwise until the Adjuster Valve bottoms-out. Then back off counter-clockwise for maximum torque as follows: UX-T, UXR-T and Alpha-T series; back off one half turn.
2. Reverse procedure for minimum torque.

UX-T, UXR-T and ALPHA-T Series Fill & Draw Sheet

Fill & Draw Sheet

Key Model of this Tool Group	Full Volume of Liner Oil in Pulse Unit (approx.)	Volume to be Removed from the Full Volume (approx.)	Torque to Tighten Liner Casing Setter (approx.)	Torque to Tighten Liner Casing Setter (approx.)	Load to Press on Rear Liner Plate	Load to Press on Rear Liner Plate
					Hydraulic Press	P.T.R.F.
Model	cc's	cc's	NM	Ft-Lbs	Tons	Ft-Lbs
U-300SD	5.0	0.15	50+/-5	37+/-4		
U-310SD / U-50EC	5.0	0.15	50+/-5	37+/-4		
U-350(S)(D)	5.0	0.15	50+/-5	37+/-4		
ULT-30(D)	5.6	0.30+/-0.01	85+/-5	63+/-4		
U-410(S)(D) & 60EC	8.5	0.35	70+/-5	52+/-4		
UX-450(S)(D)	5.0	0.50+/-0.05	70+/-5	52+/-4		
U-480	9.0	0.40	70+/-5	52+/-4	3	60
UX-500(S)(D)(C)	5.0	0.50+/-0.05	70+/-5	52+/-4		
U-501 & 80EC	9.0	0.40	70+/-5	52+/-4	3	60
ALPHA-45(S)(D) & 61(D)	5.0	0.45+/-0.05	70+/-5	52+/-4		20
ALPHA-50(S)(D) & L61(D)	5.0	0.50+/-0.05	70 +/-5	52+/-4		
ALPHA-T40D(S), T42D(S)(P), T45(S)(D)(P), T46(D), T47(S)(D)(P), T50(D) & T52(D)	5.0		70 +/-5	52+/-4		
ALPHA-50MC, 60MC & 70MC	5.0	0.45+/-0.05	70+/-5	52+/-4		
UEP-50(D) & 50MC(D)	5.5	0.35+/-0.05	70+/-5	52+/-4		
UL-50(D)	5.0	0.45+/-0.05	85+/-5	63+/-4		
ULT-40D & ULT-50(D)	5.0	0.35+0.05	85+/-5	63+/-4		
U-610	13.0	0.55	70+/-5	52+/-4	3	60
U-610T	13.0	0.55	70+/-5	52+/-4	3	60
UX-612(S)(D)(C)(A)	6.2	0.65+/-0.05	85+/-5	63+/-4		
UX-622(D)	6.2	0.65+/-0.05	85+/-5	63+/-4		
ALPHA-T60(D) & T62(D)(MI)	6.2		85+/-5	63+/-4		
ALPHA-60(S)(D)	6.2	0.55+/-0.05	85+/-5	63+/-4		
UEP-60(D) & 60MC(D)	6.8	0.55+/-0.05	85+/-5	63+/-4		
UL-60(D)	6.8	0.55+/-0.05	85+/-5	63+/-4		
ULT-60(D)	6.2	0.45+/-0.05	85+/-5	63+/-4		
U-700 & 100EC	18.0	0.90	70 +/-5	52+/-4	3	60
U-700T	18.0	0.90	70+/-5	52+/-4	3	60
UX-700(S)(D)(C) & 80EC	8.8	0.80+/-0.1	110+/-5	81+/-4	2	40
UX-T700, T700L & TL700	8.8	0.70+/-0.05	110+/-5	81+/-4	2	40
ALPHA-70(S)(C)(CH)	8.8	0.80+/-0.1	110+/-5	81+/-4	2	40
ALPHA-T65(S) & T70(S)(C)(CH)	8.8	0.75+/-0.05	110+/-5	81+/-4	2	40
UEP-70(D) & 70MC	8.8	0.65+/-0.05	110+/-5	81+/-4	2	40
UL-70	8.0	0.65+/-0.05	110+/-5	81+/-4	2	40
ULT-70	8.8	0.70+/-0.05	110+/-5	81+/-4	2	40
U-800	20.0	1.00	90+/-5	67+/-4	3	60
U-800T	20.0	1.00	90+/-5	67+/-4	3	60
UX-800(S)(C) & ST800	12.0	0.80+/-0.1	135+/-5	100+/-4	2	40

UX-T, UXR-T and ALPHA-T Series Fill & Draw Sheet (cont.)

Fill & Draw Sheet

Key Model of this Tool Group	Full Volume of Liner Oil in Pulse Unit (approx.)	Volume to be Removed from the Full Volume (approx.)	Torque to Tighten Liner Casing Setter (approx.)	Torque to Tighten Liner Casing Setter (approx.)	Load to Press on Rear Liner Plate	Load to Press on Rear Liner Plate
					Hydraulic Press	P.T.R.F.
Model	cc's	cc's	NM	Ft-Lbs	Tons	Ft-Lbs
UX-T800 & TL800	12.0	0.80+/-0.05	135+/-5	100+/-4	2	40
ALPHA-80	12.0	1.00+/-0.1	135+/-5	100+/-4	2	40
ALPHA-T80	12.0	0.80+/-0.05	135+/-5	100+/-4	2	40
ALPHA-80MC & 90MC	6.2	0.55+/-0.05	85+/-5	63+/-4		
UEP-80 & 80MC	14.0	0.9+/-0.05	150+/-5	110+/-4	3	60
U-900	25.0	1.25	100+/-5	74+/-4	3	60
U-900T	25.0	1.25	100+/-5	74+/-4	3	60
UX-900(S)(C) & 120EC	14.0	0.95+/-0.1	150+/-5	110+/-4	3	60
UX-T900 & TL900	14.0	0.95+/-0.05	150+/-5	110+/-4	3	60
ALPHA-90	14.0	1.00+/-0.1	150+/-5	110+/-4	3	60
ALPHA-T90	14.0	0.95+/-0.05	150+/-5	110+/-4	3	60
UL-90	14.0	0.95+/-0.05	150+/-5	110+/-4	3	60
ULT-90	14.0	1.0+/-0.05	150+/-5	110+/-4	3	60
U-1000	32.0	1.70	110+/-5	81+/-4	3	60
U-1000T	32.0	1.70	110+/-5	81+/-4	3	60
UX-1000(S)(C) & 130EC	19.0	1.50+/-0.1	185+/-10	137+/-7	3	60
UX-T1000 & TL1000	19.0	1.40+/-0.1	185+/-10	137+/-7	3	60
ALPHA-100	19.0	1.70+/-0.1	185+/-10	137+/-7	3	60
ALPHA-T100	19.0	1.40+/-0.1	185+/-10	137+/-7	3	60
ALPHA-100MC & 101MC	12.0	0.8+/-0.1	135+/-5	100+/-4	2	40
ALPHA-110MC	12.0	0.95+/-0.1	135+/-5	100+/-4	2	40
ULT-100	17.5	1.80+/-0.1	185+/-10	137+/-7	3	60
UX-1300(S)	24.0	1.80+/-0.1	185+/-10	137+/-7	3	60
UX-T1300 & TL1300	24.0	1.80+/-0.1	185+/-10	137+/-7	3	60
ALPHA-130	24.0	2.00+/-0.1	185+/-10	137+/-7	3	60
ALPHA-T130	24.0	1.80+/-0.1	185+/-10	137+/-7	3	60
ALPHA-130MC	24.0	1.80+/-0.1	185+/-10	137+/-7	3	60
U-1301	38.0	2.00	120+/-10	89+/-7	4	80
U-1301T	38.0	2.00	120+/-10	89+/-7	4	80
UX-1400	31.5	2.00+/-0.1	200+/-10	148+/-7	3.5	70
UX-T1400 & TL1400	31.5	1.90+/-0.1	200+/-10	148+/-7	3.5	70
ALPHA-140 & 140MC	31.5	2.30+/-0.1	200+/-10	148+/-7	3.5	70
ALPHA-T140	31.5	1.90+/-0.1	200+/-10	148+/-7	3.5	70
UX-1620	33.5	2.20+/-0.1	200+/-10	148+/-7	4	80
UX-T1620 & TL1620	33.5	2.10+/-0.1	200+/-10	148+/-7	4	80
ALPHA-160	48.0	2.40+/-0.1	260+/-10	192+/-7	4	80
UXR-1820	48.0	3.50+/-0.1	260+/-10	192+/-7	4	80
UXR-T1820 & TL1820	48.0	3.50+/-0.1	260+/-10	192+/-7	4	80
UXR-1820MC	48.0	3.50+/-0.1	260+/-10	192+/-7	4	80
ALPHA-180	48.0	4.80+/-0.1	290+/-10	214+/-7	4	80

Exploded View of the Pulse Unit

UX-T & Alpha-T Pulse Unit

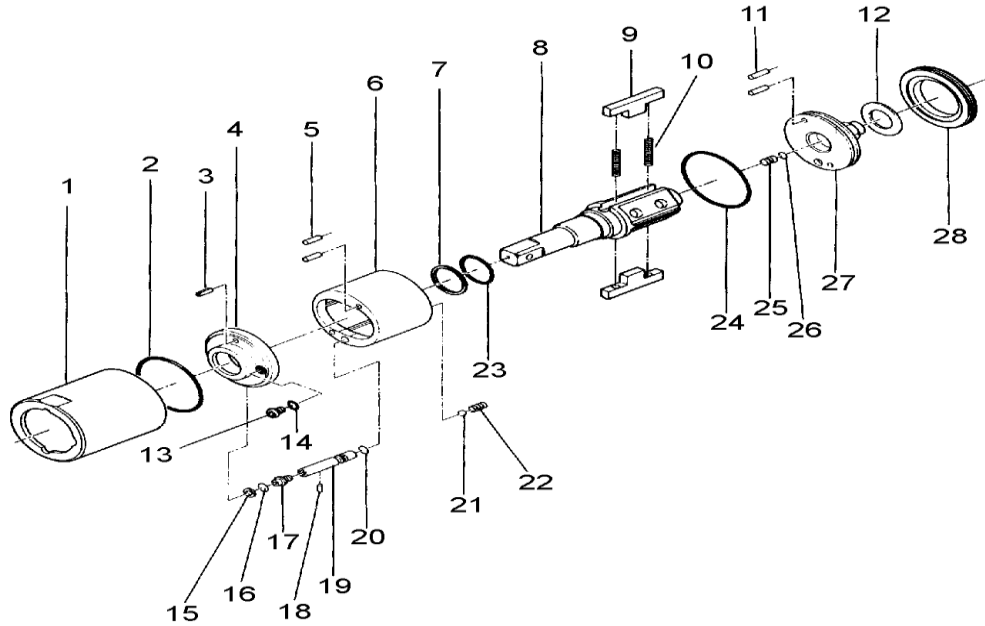

Part Number	Description	Part Number	Description
1	Liner Casing	15	Relief Valve Spindle Supporter Ring
2	Front Liner Plate O-Ring	16	Relief Valve Spindle O-Ring
3	Roll Pin	17	Relief Valve Spindle
4	Front Liner Plate	18	Relief Valve Pin
5	Locator Pins	19	Relief Valve
6	Liner	20	Relief Valve O-Ring
7	Anvil Supporter Ring	21	Relief Valve Ball
8	Anvil	22	Relief Valve Spring
9	Driving Balde	23	Anvil O-ring
10	Driving Blade Spring	24	Rear Liner Plate O-Ring
11	Locator Pins	25	Piston
12	Spacer	26	Piston O-Ring
13	Oil Fill Screw	27	Rear Liner Plate
14	Oil Fill Screw O-Ring	28	Liner Casing Setter

Recommended Maintenance

Pulse Unit

The Pulse Unit Oil should be changed every 150,000 cycles or 180 days, whichever comes first. Once a year, the Pulse Unit should be rebuilt and a repair kit installed. Remember to always use genuine Uryu Parts and Pulstar Pulse Unit Fluid.



AIMCO CORPORATE HEADQUARTERS

10000 SE Pine Street
Portland, Oregon 97216
Phone: (503) 254-6600
Toll Free: 1-800-852-1368

AIMCO CHINA

Room 607, No. 3998 Hongxin Rd Dibao Plaza
Minhang District, Shanghai
China
Phone: 0086-21-34319246
Fax: 0086-21-34319245

AIMCO CORPORATION DE MEXICO SA DE CV

Ave. Cristobal Colon 14529
Chihuahua, Chihuahua. 31125
Mexico
Phone: (01-614) 380-1010
Fax: (01-614) 380-1019

AIMCO EUROPE

Avenida Río Gallo, 431
19174 Galápagos - Guadalajara
Spain
Phone: + 34 673 34 99 25