



Signature Series

18V Cordless Precision Clutch Shut Off Angle Nutrunner



MODEL NO.: SPC-A21025Q
SPC-A21025
SPC-A21038
SPC-A21625Q
SPC-A21625
SPC-A21638
SPC-A23038
SPC-A23538
SPC-A25038

INSTRUCTION MANUAL

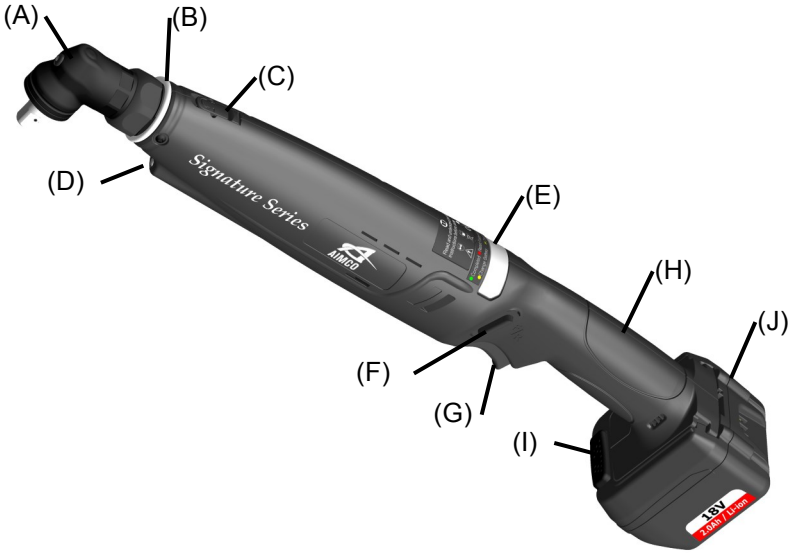

| | |
|-----|--|
| (A) | The angled head is indexable for multiple head positions. |
| (B) | User can distinguish wrench model with color ring. |
| (C) | Covered Torque Adjustment. |
| (D) | LED light for workpiece illumination. |
| (E) | LED indicator provides simple process information to the operator. The signal is visible from any angle. |
| (F) | Easy Press button for simple Forward/Reverse selection. |
| (G) | Tool Trigger with repeat protection feature to avoid double hits on already seated fastener. |
| (H) | Ergonomic handle design provides optimal balance. |
| (I) | Easy attached sliding battery system. |
| (J) | Lightweight Li-Ion battery pack delivers long tool operating times. |

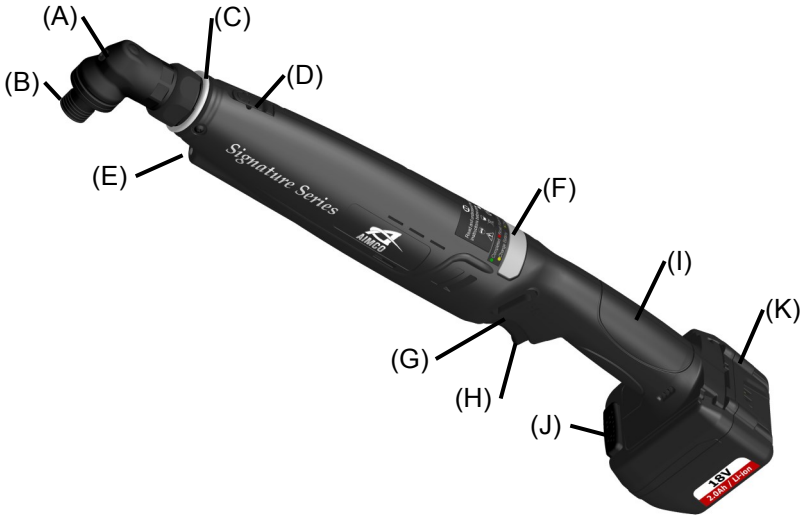

| | |
|-----|--|
| (A) | The angled head is indexable for multiple head positions. |
| (B) | 1/4" Hex with quick change chuck. |
| (C) | User can distinguish wrench model with color ring. |
| (D) | Covered Torque Adjustment. |
| (E) | LED light for workpiece illumination. |
| (F) | LED indicator provides simple process information to the operator. The signal is visible from any angle. |
| (G) | Easy Press button for simple Forward/Reverse selection. |
| (H) | Tool Trigger with repeat protection feature to avoid double hits on already seated fastener. |
| (I) | Ergonomic handle design provides optimal balance. |
| (J) | Easy attached sliding battery system. |
| (K) | Lightweight Li-Ion battery pack delivers long tool operating times. |

WARNING! READ ALL INSTRUCTIONS. Always observe the safety regulations applicable in your country to reduce the risk of fire, electric shock, and personal injury. Understand the following safety instructions before attempting to operate this product. Always wear eye protection when working with power tools. Keep these instructions in a safe place.

SAVE THESE INSTRUCTIONS

General Safety Rules

Work Area Safety

- **Keep your work area clean and well lit.** Cluttered benches and dark areas invite accidents.
- **Do not operate power tools in explosive atmospheres, such as in the presence of flammable liquids, gases, or dust.** Power tools create sparks which may ignite the dust or fumes.
- **Keep bystanders, children, and visitors away while operating a power tool.** Distractions can cause you to lose control.

Personal Safety

- **Stay alert, watch what you are doing and use common sense when operating a power tool. Do not use tool while tired or under the influence of drugs, alcohol, or medication.** A moment of inattention while operating power tools may result in serious personal injury.
- **Dress properly. Do not wear loose clothing or jewelry. Contain long hair. Keep your hair, clothing, and gloves away from moving parts.** Loose clothes, jewelry, or long hair can be caught in moving parts.
- **Do not overreach. Keep proper footing and balance at all times.** Proper footing and balance enables better control on the tool in unexpected situations.

- **Use safety equipment. Always wear eye protection.** Dust mask, non-skid safety shoes, hard hat, or hearing protection must be used for appropriate conditions.

Tool Use and Care

- **Use clamps or other practical ways to secure and support the work piece to a stable platform.** Holding the work piece by hand or against your body is unstable and may lead to loss of control.
- **Do not force tools. Use the correct tool for your application.** The correct tool will do the job better and safer at the rate for which it is designed.
- **Do not use tool if switch does not turn it on or off.** Any tool that cannot be controlled with the switch is dangerous and must be repaired.
- **Store idle tools out of reach of children and other untrained persons.** Tools are dangerous in the hands of untrained users.
- **Check for misalignment or binding of moving parts, breakage of parts, and any other condition that may affect the tool operation. If damaged, have the tool serviced before using.** Many accidents are caused by poorly maintained tools.
- **Use only Signature Series recommended accessories for your model tool.** Accessories that may be suitable for one tool, may become hazardous when used on another tool.

Service

- **Tool service must be performed only by qualified repair personnel.** Service or maintenance performed by unqualified personnel could result in a risk of injury.
- **When servicing an AIMCO Signature Series Precision Clutch tool it is important to use AIMCO Signature Series parts and all work should be undertaken by a qualified AIMCO Signature Series Authorized Technician.** Use of unauthorized parts or work performed by a non-authorized technician will void warranty and may create a risk of damage to the tool, risk of electric shock, or injury to a user.

Additional Safety Rules

Battery Charger

- **Caution:** To reduce risk of injury, charge only the authorized batteries. Other types of batteries may burst, causing personal injury and damage.
- Before using battery charger, read all instructions and cautionary markings on batteries, chargers, and products using batteries.
- Do not allow anything to cover or clog the charger vents.
- Do not expose charger to rain, snow, or wet conditions.
- To reduce the risk of damage to electric plug and cord, pull by plug rather than cord when disconnecting charger.
- Use of an attachment not recommended or sold by the manufacturer may result in a risk of fire, electric shock, or injury to persons.
- Make sure cord for charger is located so that it will not be stepped on, tripped on, tripped over, or otherwise subjected to damage or stress.

- Do not abuse the power cord. Never use the cord to carry the charger. Keep cord away from heat, oil, water, sharp edges, or moving parts. Replace damaged cords immediately.
- Do not operate charger if it has been damaged in any way. Take it to a qualified service center for repair.
- To reduce risk of electric shock, unplug charger from outlet before attempting any maintenance or cleaning. Turning off controls will not reduce this risk.
- Do not disassemble charger or battery cartridge. Take it to a qualified service center when repair is required. Incorrect reassembly may result in a risk of electric shock or fire.

Battery Pack

- Do not charge battery pack when temperature is below 0°C (32°F) or above 40°C (104°F).
- Do not attempt to use a step-down transformer, an engine generator, or DC power receptacle.
- Do not short the battery pack: Do not touch the terminals with any conductive material. Avoid storing battery cartridge in a container with other metal objects such as nails, coins, paper clips, etc.
- Do not expose battery cartridge to water or rain. A battery short can cause large current flow, overheating, possibly burns, and even a breakdown.
- Do not store the machine and battery pack in locations where the temperature may reach or exceed 50°C (122°F).
- Do not incinerate the battery pack even if it is severely damaged or completely worn out. The battery pack can explode in a fire.
- Be careful not to drop, shake, or strike the battery.

- Do not charge inside a box or container of any kind. The battery must be placed in a well-ventilated area during charging.
- Do not dispose of battery packs into household waste, fire or water. Battery packs should be collected, recycled or disposed of in an environmentally-friendly manner. Call authorized warranty centers for locations to dispose of damaged or inoperable batteries.

Functional Description

The Signature Series Precision Clutch industrial shut off wrench is designed for nut tightening/loosening and screw driving/loosening. It is not appropriate to use for wood/mild steel drilling. Please refer to the Figure 1 on this page to familiarize yourself with the major components of this tool before use.

1. Power Switch

Depressing the power switch will energize the LED light (2) in front and the tool starts to rotate. When released, power to the motor ceases and the tool stops working immediately. The LED light will remain on for 5 seconds, then shut off.

2. LED Light

3. Forward/Reverse Button

The tool is always in forward operation unless the Forward/Reverse button is pressed. When the button is pressed, the blue LED shows and the tool will be in reverse operation. To switch tool back to forward operation, simply press the button again. The blue LED disappears and the tool is back in forward operation.

4. Anvil (Drive Shaft)

The anvil will accept any 1/4" hex bit or 3/8" square drive hex socket depending on specific model. Be sure the bit/socket is fully en-

gaged before operating the tool. Otherwise, the bit/socket may detach and cause property damage or personal injury. Use only impact-type sockets or industrial grade bits.

5. Angle Head Orientation

Adjust the angle head kit to the degree you wish. (in 45° increments for a total of eight positions for head orientation).

6. Torque Adjustment Cover

Open the torque adjustment cap. Use the supplied torque adjustment tool to either tighten or loosen the spring until the desired torque is reached.

7. Li-Ion Battery

This battery provides electrical power to the motor. Please charge it according to the charging instructions listed in this manual.

WARNING: Use the tool to either tighten or loosen nuts and screws ONLY in stipulated torque and voltage ranges.



Figure 1

Assembly

Check for damage to the tool, parts, or accessories that may have occurred during transport. Take the time to thoroughly read and understand this manual prior to operation.

This tool kit contains:

- 1 - 18V Signature Series Cordless Precision Clutch Shut off Angle Tool
- 1 - 18V Li-Ion Battery Pack
- 1 - Torque Adjustment Tool
- 1 - Angle Head Adjustment Tool
- 4 - Color Rings for tool Identification
- 1 - Instruction Manual

Attaching or Removing Battery Pack

1. To connect battery, line up the tracks and attach the battery pack. Slide toward the battery pack until it locks into position with a click.

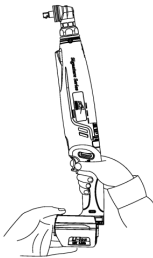

SLIDE →

2. To remove the battery pack, press the red button on the top of the battery pack and release the battery pack.

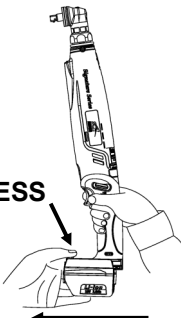

1. PRESS

2. RELEASE ←

Operations

This product has been carefully inspected prior to leaving the factory. It should provide you with years of satisfying service under normal operating conditions. Do not, however, force the tool to perform outside its design parameters. Such usage will void the warranty.

WARNING! Read the instruction manual before operating the tool. Always wear safety glasses or face shields when operating this product. Failure to do so can result in injury.

1. Slide battery into the bottom of the housing handle until a click sound occurs. Do not force battery: It should slide easily into place with nominal force. Any difficulty doing so indicates incorrect alignment.
2. Tool speed is preset to the maximum range of the tool. With an **SPC-2PGM** External Programming Module (optional accessory), tool speeds may be reset to a lower speed within the range of the tool.
3. Select a proper size socket/drive bit and insert into the quick change holder or install onto the square drive of the tool.
4. Depress the trigger to engage the LED light and start the tool.
5. When the pre-set torque is reached, the tool's precision clutch will shut off the tool automatically.
6. Prior to using on an application, it is advised to verify the output torque of the tool as set. Check the torque on an **Auditor™ Digital Tester** (or comparable system).

7. Delivered torque to the application may vary due to the type of joint the tool is tightening. Good practice is to perform periodic audits of the application. **Auditor™ Torque Wrenches of Rotary Transducers** are ideally suited to make these checks.

Forward/Reverse Rotation Switch Operation

To prevent damage, do not press Forward/Reverse button until the tool comes a complete stop.

Forward Rotation Operation

The tool is in forward operation if the blue light is not on.

Reverse Rotation Operation

By long pressing the F/R switch, users are able to choose the mode of reverse operation, either automatic or manual.

Mode 1: Automatic – Tool returns to forward operation automatically after reverse operation.

Mode 2: Manual – Tool needs to be adjusted manually to return to forward operation after reverse operation.

Steps for Torque Adjustment

NOTE: Remove the battery pack before adjusting the torque to avoid injury.

1. Open the cover and use an open end wrench (or torque adjustment tool on quick change models) to rotate the square drive until the adjust hole position appears below the cover.

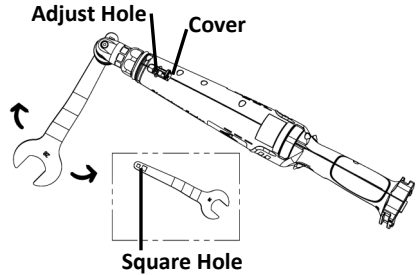

2. Turn the torque adjustment tool clockwise to increase the torque and counterclockwise to decrease the torque.

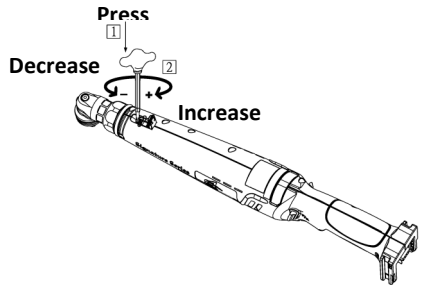

Steps for Angle Head Position Indexing

1. Use an open end wrench and the supplied adjustment wrench to loosen the nut by turning in the opposite direction to remove the angle head assembly.
2. Adjust the angle head assembly to the degree you wished then put it back on the tool (in 45° increments for a total of eight positions for head orientation).

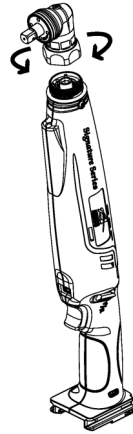
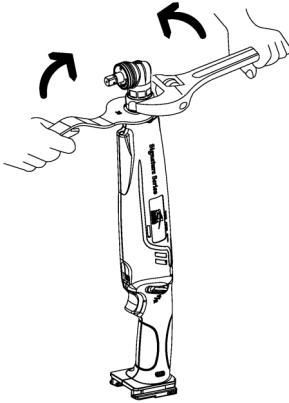

3. Use an open end wrench and the supplied adjustment wrench to tighten the nut by turning in opposite direction to complete angle adjustment.

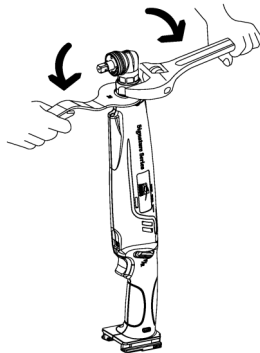

TOOL LED INDICATIONS

| Status of the LED indicator and Beep | Status of the Tool | Action to be Taken |
|---|---|---|
| LED lights RED, YELLOW, and GREEN together for one second. A long beep for one second. | The motor is switched on. | None required. |
| LED lights RED for one second. A long beep for one second. | The preset torque is not reached (NOK). | The application should be re-worked. |
| | The screw has been refastened after already tight-Double Hit (NOK). | The application should be reworked. |
| LED lights GREEN. | The preset torque is reached and the tightening is OK. | None required. |
| LED Blinks YELLOW five times. Five short beeps. | Battery power is low. | Recharge battery or replace with fully charged battery. |
| LED lights YELLOW for five seconds. A long beep for five second. | Battery power is too low for tool operation and tool will not run, | Recharge battery or replace with fully charged battery. |
| LED lights BLUE, | The tool is set to run in reverse operation, | None required. |
| LED lights RED twice, | Tool temperature is too hot. Warning to protect tool from damage, | Remove battery and allow tool to cool. |
| LED lights RED three times | The motor has a failure, | Send tool in for service. |
| LED lights RED four times, | Internal connector wire has failed. | Send tool in for service. |

CHARGING THE BATTERY PACK

Li-ion Battery Pack

NOTE: Your battery pack is not fully charged at the time of purchase. Be sure to charge battery before first use.

- Batteries should be charged in ambient temperatures between 0° C (32°F) and 40°C (104°F). Charging outside this range will result in either less than full charge or damage to the battery pack.
 - Allow the charger to cool when charging more than two battery packs consecutively.
 - Do not insert finger/body parts or foreign objects into contact area of charger.
1. Place charger in a relatively cool and well-ventilated area.
 2. Plug charger into the AC outlet. CAUTION: Ensure that the power source to be utilized conforms to the power requirement specified on the charger nameplate.
 3. Turn the battery upside-down and slide the battery into charger while keeping the alignment marks line up. Slide the forward in the direction of the arrow. Do not force battery: It should slide easily into place with nominal force. Any difficulty doing so indicates incorrect alignment.



4. If the power lamp (RED) does not light immediately or goes out soon after the charger is plugged in, consult a **Signature Series** authorized dealer.
5. During charging, the charging lamp (GREEN) will start flashing. When charging is completed, an internal electronic switch will automatically be triggered to prevent overcharging.
 - Charging will not start if the battery pack is warm. For example, immediately after high duty cycle operation. The YELLOW standby lamp will flash until the battery temperature drops to where safe charging is possible.
6. If the temperature of the battery pack is 0°C (32°F) or less, charging will take longer to fully charge the battery pack than standard charging time. At this low temperature, even when the battery is fully charged, it will have approximately 50% of the power of a fully charged battery at normal operation temperatures.
7. Once the battery is fully charged, the GREEN lamp will light to indicate the charger has entered into a trickle charge mode.

LAMP INDICATIONS



Red Light

Charger is plugged into the AC outlet. Ready to charge.



Yellow Flashing Light

- (1) When the temperature of the battery is too low ($<0^{\circ}\text{C}$ ($<32^{\circ}\text{F}$)), it is in a trickle charge mode until the temperature of the battery goes up to over 0°C ($<32^{\circ}\text{F}$). The lamp will change from the Yellow Flashing to Green Flashing automatically and start to charge. (If after 70 minutes, the lamp changes from yellow flashing to yellow lit, consult an authorized dealer.)
- (2) When the temperature of the battery is too high ($>40^{\circ}\text{C}$ (104°F)), it is in a trickle charge mode until the temperature of the battery drops to under 40°C (104°F). The lamp will change from the Yellow Flashing to Green Flashing automatically and start to charge. (If after 70 minutes, the lamp changes from yellow flashing to yellow lit, consult an authorized dealer.)
- (3) When the voltage of the battery is too low (below 14.4 voltage), it is in a trickle charge mode until the voltage of the battery reaches to the standard value. The lamp will change from the Yellow Flashing to Green Flashing automatically and start to charge. (If after 20 minutes, the lamp changes from yellow flashing to yellow lit, consult an authorized dealer.)



Yellow Light

The battery and the charger are not connected. If the yellow lit still on after trying re-attach the battery, consult an authorized dealer.



Green Flashing Light

Now start charging Light



Green Flashing Light

Battery is approximately 50% charged.



Green Flashing Light

Battery is approximately 80% charged.



Green Light

Charging is complete. (Fully charged.)

SPECIFICATIONS

| | <u>MODEL</u> | |
|-------------------------------|-------------------------------|-------------------------------|
| | SPC-A21025Q | SPC-A21025 |
| Voltage | 18 VDC | 18 VDC |
| Drive Size | 6.35 mm Hex. (1/4") | 6.35 mm Sq. (1/4") |
| Screw Size | M4 ~ M5 | M4 ~ M5 |
| Torque Range (Hard Joint) | 3 ~ 12 Nm (26 ~ 106 in-lb) | 3 ~ 12 Nm (26 ~ 106 in-lb) |
| Torque Range (Soft Joint) | 3 ~ 10 Nm (26 ~ 89 in-lb) | 3 ~ 10 Nm (26 ~ 89 in-lb) |
| Free Speed | 400 ~ 1000 rpm | 400 ~ 1000 rpm |
| Weight w/o Battery | 1.6 kg (3.5 lb) | 1.6 kg (3.5 lb) |
| Vibration (m/s ²) | 2.63 | 2.63 |
| Sound level (dB(A)) | <75 | <75 |
| Battery Type | Li-Ion 2.0A.h | Li-Ion 2.0A.h |
| Charge Time | Approx. 45 min | Approx. 45 min |

| | <u>MODEL</u> | |
|-------------------------------|-------------------------------|-------------------------------|
| | SPC-A21038 | SPC-A21625Q |
| Voltage | 18 VDC | 18 VDC |
| Drive Size | 9.5 mm Sq. (3/8") | 6.35 mm Hex. (1/4") |
| Screw Size | M4 ~ M5 | M5 ~ M6 |
| Torque Range (Hard Joint) | 3 ~ 12 Nm (26 ~ 106 in-lb) | 5 ~ 18 Nm (44 ~ 159 in-lb) |
| Torque Range (Soft Joint) | 3 ~ 10 Nm (26 ~ 89 in-lb) | 5 ~ 16 Nm (44 ~ 142 in-lb) |
| Free Speed | 400 ~ 1000 rpm | 300 ~ 600 rpm |
| Weight w/o Battery | 1.6 kg (3.5 lb) | 1.6 kg (3.5 lb) |
| Vibration (m/s ²) | 2.63 | 2.63 |
| Sound level (dB(A)) | <75 | <75 |
| Battery Type | Li-Ion 2.0A.h | Li-Ion 2.0A.h |
| Charge Time | Approx. 45 min | Approx. 45 min |

SPECIFICATIONS

| | <u>MODEL</u> | |
|-------------------------------|-------------------------------|-------------------------------|
| | SPC-A21625 | SPC-A21638 |
| Voltage | 18 VDC | 18 VDC |
| Drive Size | 6.35 mm Sq. (1/4") | 9.5 mm Sq. (3/8") |
| Screw Size | M5 ~ M6 | M5 ~ M6 |
| Torque Range (Hard Joint) | 5 ~ 18 Nm (44 ~ 159 in-lb) | 5 ~ 18 Nm (44 ~ 159 in-lb) |
| Torque Range (Soft Joint) | 5 ~ 16 Nm (44 ~ 142 in-lb) | 5 ~ 16 Nm (44 ~ 142 in-lb) |
| Free Speed | 300 ~ 600 rpm | 300 ~ 600 rpm |
| Weight w/o Battery | 1.6 kg (3.5 lb) | 1.6 kg (3.5 lb) |
| Vibration (m/s ²) | 2.63 | 2.63 |
| Sound level (dB(A)) | <75 | <75 |
| Battery Type | Li-Ion 2.0A.h | Li-Ion 2.0A.h |
| Charge Time | Approx. 45 min | Approx. 45 min |

| | <u>MODEL</u> | | |
|-------------------------------|-------------------------------|--------------------------------|--------------------------------|
| | SPC-A23038 | SPC-A23538 | SPC-A25038 |
| Voltage | 18 VDC | 18 VDC | 18 VDC |
| Drive Size | 9.5 mm Sq. (3/8") | 9.5 mm Sq. (3/8") | 9.5 mm Sq. (3/8") |
| Screw Size | M6 ~ M8 | M6 ~ M8 | M8 ~ M10 |
| Torque Range (Hard Joint) | 8 ~ 30 Nm (71 ~ 266 in-lb) | 10 ~ 35 Nm (89 ~ 310 in-lb) | 10 ~ 50 Nm (89 ~ 443 in-lb) |
| Torque Range (Soft Joint) | 8 ~ 22 Nm (71 ~ 195 in-lb) | 10 ~ 30 Nm (89 ~ 266 in-lb) | 10 ~ 45 Nm (89 ~ 398 in-lb) |
| Free Speed | 250 ~ 480 rpm | 200 ~ 330 rpm | 200 rpm |
| Weight W/O Battery | 1.6 kg (3.5 lb) | 1.6 kg (3.5 lb) | 1.6 kg (3.5 lb) |
| Vibration (m/s ²) | 2.55 | 2.55 | 2.55 |
| Sound level (dB(A)) | <75 | <75 | <75 |
| Battery Type | Li-Ion 2.0A.h | Li-Ion 2.0A.h | Li-Ion 2.0A.h |
| Charge Time | Approx. 45 min | Approx. 45 min | Approx. 45 min |

NOISE AND VIBRATION LEVEL DECLARATION (Max. value) EN 60745-2-2

Models: 16 Nm and below

Sound pressure level (no load) L_{pA} : 66.7 dBA

Uncertainty K: 1.5 dB

Sound power level (no load) L_{wA} : 77.7 dBA

Uncertainty K: 1.5 dB

Vibration total value (no load) a_{hd} : 0.6 m/s²

Uncertainty K: 1.5 m/s²

Models: 30 Nm and above

Sound pressure level (no load) L_{pA} : 67.8 dBA

Uncertainty K: 1.5 dB

Sound power level (no load) L_{wA} : 78.8 dBA

Uncertainty K: 1.5 dB

Vibration total value (no load) a_{hd} : 0.3 m/s²

Uncertainty K: 1.5 m/s²

The declared noise levels and vibration total value has been measured in accordance with a standard test method and may be used for comparing one tool with another. The declared noise levels and vibration total value may also be used in a preliminary assessment of exposure.

WARNING:

- The noise and vibration emission during actual use of the power tool can differ from the declared total value depending on the ways in which the tool is used; and
- Need to identify safety measures to protect the operator that are based on an estimation of exposure in the actual conditions of use (taking account of all parts of the operating cycle such as the times when the tool is switched off and when it is running idle in addition to the trigger time).

ANGLE HOUSING UNITS

For Models: SPC-A21025 SPC-A21625

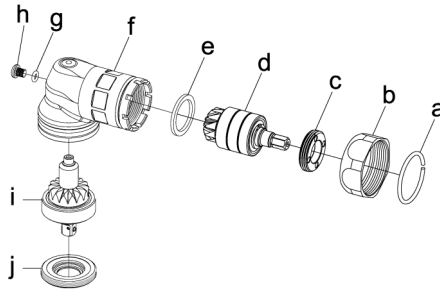

| Index No | Description | Q'ty | Index No | Description | Q'ty |
|----------|--------------------------|------|----------|------------------------|------|
| a | Collar | 1 | f | Angle Housing Assembly | 1 |
| b | Lock Nut | 1 | g | O-Ring | 1 |
| c | Lock Nut | 1 | h | Screw | 1 |
| d | Main Bevel Gear Assembly | 1 | i | Bevel Gear Assembly | 1 |
| e | Washer | 1 | j | Lock Nut | 1 |

For Models: SPC-A21038 SPC-A21638 SPC-A23038
SPC-A23538 SPC-A25038

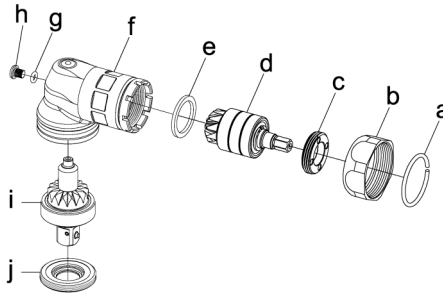

| Index No | Description | Q'ty | Index No | Description | Q'ty |
|----------|--------------------------|------|----------|------------------------|------|
| a | Collar | 1 | f | Angle Housing Assembly | 1 |
| b | Lock Nut | 1 | g | O-Ring | 1 |
| c | Lock Nut | 1 | h | Screw | 1 |
| d | Main Bevel Gear Assembly | 1 | i | Bevel Gear Assembly | 1 |
| e | Washer | 1 | j | Lock Nut | 1 |

Specific Part Numbers may be obtained by review of the correct Signature Series tool breakdown. Consult your Signature Series dealer for details.

ANGLE HOUSING UNITS

For Models: SPC-A21025Q SPC-A21625Q

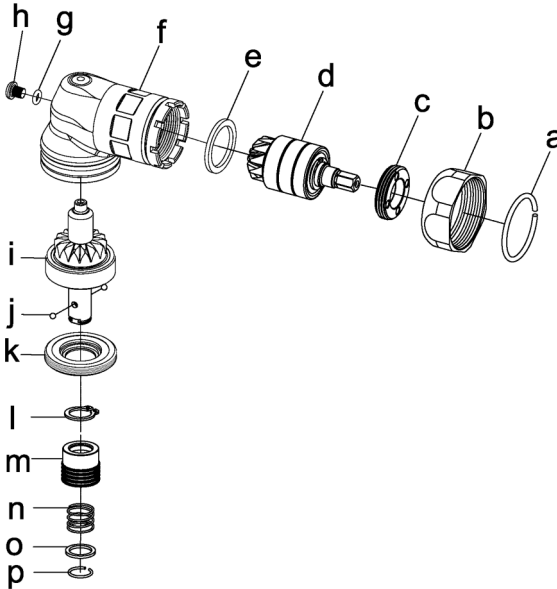

| Index No | Description | Q'ty | Index No | Description | Q'ty |
|----------|--------------------------|------|----------|---------------------|------|
| a | Collar | 1 | i | Bevel Gear Assembly | 1 |
| b | Lock Nut | 1 | j | Steel Ball | 2 |
| c | Lock Nut | 1 | k | Lock Nut | 1 |
| d | Main Bevel Gear Assembly | 1 | l | Snap Ring | 1 |
| e | Washer | 1 | m | Quick Change Holder | 1 |
| f | Angle Housing Assembly | 1 | n | Spring | 1 |
| g | O-Ring | 1 | o | Hold Spacer | 1 |
| h | Screw | 1 | p | Anvil Collar | 1 |

Specific Part Numbers may be obtained by review of the correct Signature Series tool breakdown. Consult your Signature Series dealer for details.

CLUTCH UNITS

For Models: SPC-A21025Q
 SPC-A21038
 SPC-A21625
 SPC-A23038
 SPC-A25038

SPC-A21025
 SPC-A21625Q
 SPC-A21638
 SPC-A23538

Note Use grease of type
 Molykote: Br2 Plus
 or equivalent

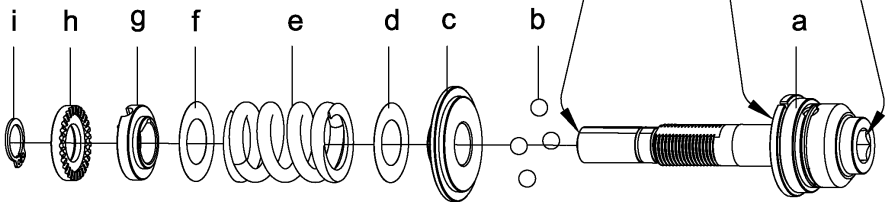



| Index No | Description | Q'ty | Index No | Description | Q'ty |
|----------|-----------------|------|----------|---------------|------|
| a | Clutch Assembly | 1 | f | Washer | 1 |
| b | Steel Ball | 4 | g | Adjust Washer | 1 |
| c | Washer | 1 | h | Adjust Nut | 1 |
| d | Washer | 1 | i | Snap Ring | 1 |
| e | Spring | 1 | | | |

Specific Part Numbers may be obtained by review of the correct Signature Series tool breakdown. Consult your Signature Series dealer for details.

GEAR BOX UNITS

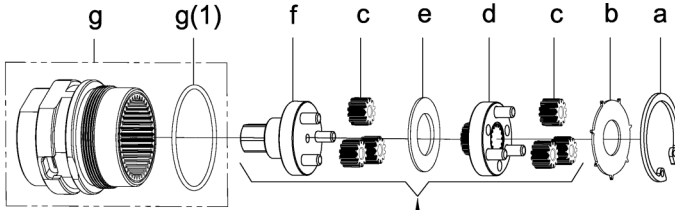
For Models: **SPC-A21025Q** **SPC-A21025** **SPC-A21038**



Note Use grease of type Molykote: Br2 Plus or equivalent 

| Index No | Description | Q'ty | Index No | Description | Q'ty | Index No | Description | Q'ty |
|----------|-------------|------|----------|---------------------|------|----------|---------------------------------|------|
| a | Snap Ring | 1 | d | Gear Cage Assembly | 1 | g | Gear Box Assembly (1) O-ring | 1 |
| b | Washer | 1 | e | Washer | 1 | | | 1 |
| c | Planet Gear | 6 | f | Gear Plate Assembly | 1 | | | |

For Models: **SPC-A21625Q** **SPC-A21625** **SPC-A21638**
SPC-A23038 **SPC-A23538** **SPC-A25038**

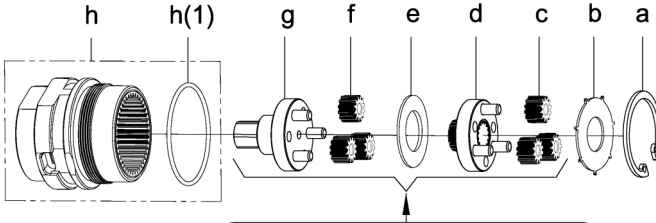

Note Use grease of type Molykote: Br2 Plus or equivalent 

| Index No | Description | Q'ty | Index No | Description | Q'ty | Index No | Description | Q'ty |
|----------|-------------|------|----------|--------------------|------|----------|---------------------------------|------|
| a | Snap Ring | 1 | d | Gear Cage Assembly | 1 | g | Gear Plate Assembly | 1 |
| b | Washer | 1 | e | Washer | 1 | h | Gear Box Assembly (1) O-ring | 1 |
| c | Planet Gear | 3 | f | Planet Gear | 3 | | | 1 |

Specific Part Numbers may be obtained by review of the correct Signature Series tool breakdown. Consult your Signature Series dealer for details.

HOUSING AND MOTOR

For Models: SPC-A21025Q SPC-A21025 SPC-A21038

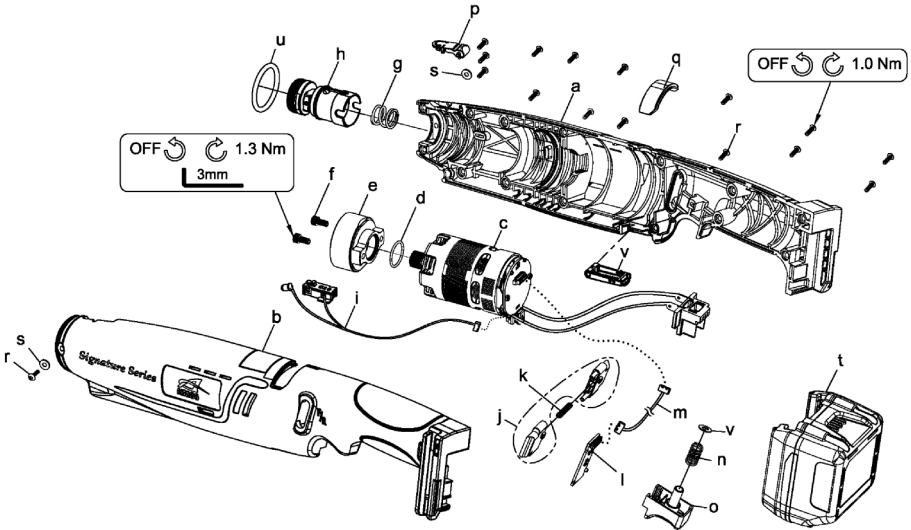

| Index No | Description | Q'ty | Index No | Description | Q'ty |
|----------|-----------------------------------|------|----------|--------------------------|------|
| a | Upper Housing | 1 | l | PC Board | 1 |
| b | Lower Housing | 1 | m | Connector Wire | 1 |
| c | Brushless Motor Assembly w/driver | 1 | n | Spring | 1 |
| d | O-Ring | 1 | o | Trigger Assembly | 1 |
| e | Motor Holder | 1 | p | Cover | 1 |
| f | Screw | 2 | q | Cover | 1 |
| g | Spring | 1 | r | Screw | 16 |
| h | Connecting Holder Assembly | 1 | s | Washer | 2 |
| i | Sensor & LED Assembly | 1 | t | 18V Li-Ion 2.0Ah Battery | 1 |
| j | F/R Valve (1set×2pcs) | 1 | u | Marking Ring | 1 |
| k | Spring | 1 | v | Washer | 1 |

Specific Part Numbers may be obtained by review of the correct Signature Series tool breakdown. Consult your Signature Series dealer for details.

HOUSING AND MOTOR

For Models: SPC-A21625Q SPC-A21625 SPC-A21638 SPC-A23038

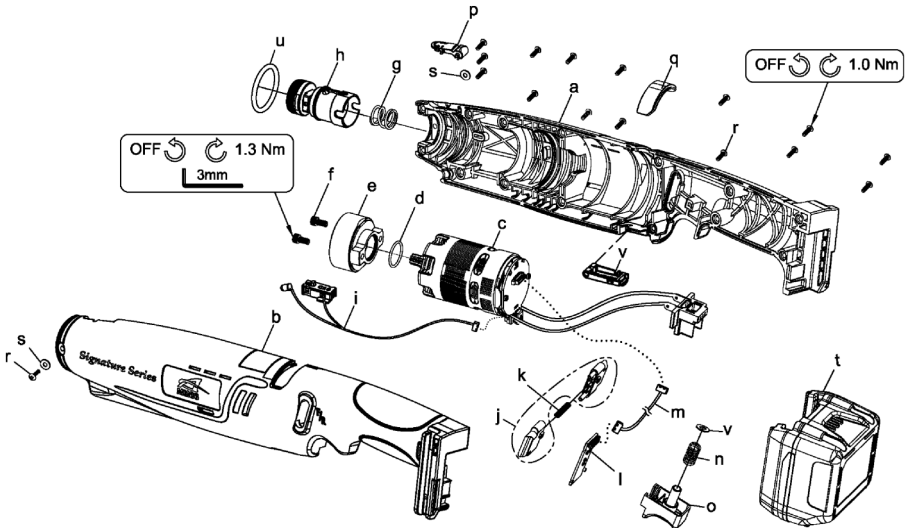

| Index No | Description | Q'ty | Index No | Description | Q'ty |
|----------|-----------------------------------|------|----------|--------------------------|------|
| a | Upper Housing | 1 | l | PC Board | 1 |
| b | Lower Housing | 1 | m | Connector Wire | 1 |
| c | Brushless Motor Assembly w/driver | 1 | n | Spring | 1 |
| d | O-Ring | 1 | o | Trigger Assembly | 1 |
| e | Motor Holder | 1 | p | Cover | 1 |
| f | Screw | 2 | q | Cover | 1 |
| g | Spring | 1 | r | Screw | 16 |
| h | Connecting Holder Assembly | 1 | s | Washer | 2 |
| i | Sensor & LED Assembly | 1 | t | 18V Li-Ion 2.0Ah Battery | 1 |
| j | F/R Valve (1 set x 2 pcs) | 1 | u | Marking Ring | 1 |
| k | Spring | 1 | v | Washer | 1 |

Specific Part Numbers may be obtained by review of the correct Signature Series tool breakdown. Consult your Signature Series dealer for details.

HOUSING AND MOTOR

For Models: SPC-A23538 SPC-A25038

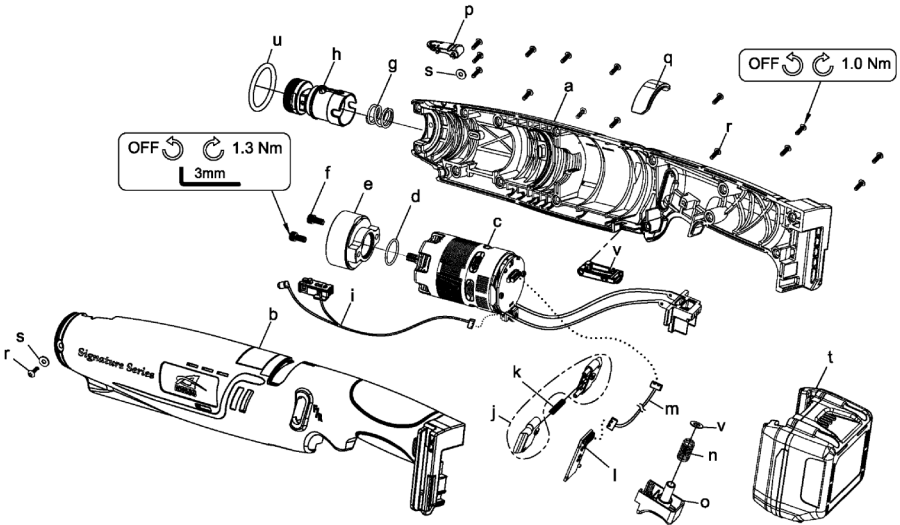

| Index No | Description | Q'ty | Index No | Description | Q'ty |
|----------|-----------------------------------|------|----------|--------------------------|------|
| a | Upper Housing | 1 | l | PC Board | 1 |
| b | Lower Housing | 1 | m | Connector Wire | 1 |
| c | Brushless Motor Assembly w/driver | 1 | n | Spring | 1 |
| d | O-Ring | 1 | o | Trigger Assembly | 1 |
| e | Motor Holder | 1 | p | Cover | 1 |
| f | Screw | 2 | q | Cover | 1 |
| g | Spring | 1 | r | Screw | 16 |
| h | Connecting Holder Assembly | 1 | s | Washer | 2 |
| i | Sensor & LED Assembly | 1 | t | 18V Li-Ion 2.0Ah Battery | 1 |
| j | F/R Valve (1 set x 2 pcs) | 1 | u | Marking Ring | 1 |
| k | Spring | 1 | v | Washer | 1 |

Specific Part Numbers may be obtained by review of the correct Signature Series tool breakdown. Consult your Signature Series dealer for details.



Corporate Headquarters

10000 SE Pine Street
Portland, OR 97216
800-852-1368
FAX 800-582-9015
www.aimco-global.com

Ave. Cristóbal Colon 14529
Chihuahua, Chihuahua. 31125
Mexico
011-52-(614) 380-1010
FAX 011-52-(614) 380-1019