



Operation and Service Manual

ABG Series
Battery
Powered
Nutrunners

Congratulations on your purchase of an ABG Battery-Powered Nutrunner. You have acquired a superior quality product that sets international standards and meets the highest safety requirements. To ensure continued compliance with these requirements, the device needs to be maintained and serviced regularly. We therefore suggest that you read these operating and service instructions carefully and observe the following:

The ABG Nutrunner and the supplied Battery Charger may only be serviced and repaired by authorized AIMCO service personnel.

If health hazards or material damages to the device occur because of improper maintenance or operation, the warranty will be rendered null and void.

This operating and service manual contains basic information to be observed during operation and maintenance. The operating personnel is required to read these instructions before operation or maintenance. The manual must be available and accessible at the location of the AcraDyne tools/devices. This operating and maintenance manual refers exclusively to the AcraDyne ABG Battery-Powered Nutrunners, AcraDyne Li-Ion battery packs, and the AcraDyne charger station.

Please observe not only the general safety notices and warnings listed below, but also observe all generally applicable regulations, directives, and warnings.

Identification of Notices



Safety notice for the prevention of hazard to life and limb of persons.



Safety notice for the prevention of damage to AcraDyne tools, devices, their functions, and the environment.



Notice regarding proper and safe operation.



Advice to make work easier.

Content	Page
Incoming Inspection and Packaging	3
General Description	3
Model Description	3
1. Technical Data	4
2. Safety instructions	4
2.1 Intended Use	4
2.2 Operators Responsibilities	4
2.3 Hazard Notices	5
3. Operating the Charger Station	5
3.1 Self-Test	5
3.2 Starting	5
4. Operating the AcraDyne ABG Nutrunner	6
4.1 Starting	6
4.1.1 Remove, Charge, Insert, or Change Li-Ion Battery Pack	6
4.1.1 Battery Pack, Capacity, and Signal Display	6
4.2 Preparing for Work with the Power Tool	7
5. Electric Operation	7
5.1 Switching On / Off	7
5.2 Direction of Rotation, Transport Lock	8
5.3 Gear Change	8
5.4 Setting the Shut-Off Torque	8
6. Mechanical Operation	9
6.1 Safety Instruction for Tightening and Loosening	9
6.1.1 Tightening and Loosening	9
7. Function and Operation Test	10
7.1 Visual and Mechanical Inspection	10
8. Servicing / Storage / Maintenance	10
8.1 Replacing Accessories	10
8.2 Storage in Lockable Containers	10
8.3 Decommissioning	10
8.4 Service and Maintenance	10
9. Technical Notes	11
9.1 Safety Shut-Off	11
9.2 Causes and Problem Solving	11
10. Noise Level and Vibration	11
11. Environmental Protection	11

Incoming Inspection and Packaging

The product is shipped with the following:

One (1) AcraDyne ABG Battery-Powered Nutrunner, two (2) high-performance Li-ion rechargeable battery packs, and one (1) AcraDyne charger station.



All parts must be visually inspected for possible transport damages. If any such damage is identified, please notify the shipping agent immediately. All returns must be in the original packaging to prevent damages to the tools/devices. Always retain packaging for future use.

General Description

AcraDyne ABG Battery-Powered Nutrunners are continuously rotating power tools. Nuts/bolts are tightened or loosened with a high torque and when a set value or required final torque value is reached, the machine is switched off. The device is driven with a maintenance-free, low-wear brushless synchronous motor. The tool has a wide torque range and is capable of high assembly speed.

Model Description

AcraDyne ABG Battery-Powered Nutrunners are dual-gear nutrunners with rechargeable batteries and torques* of 90 Nm to 4,000 Nm. A constant torque precision and exact shut-off torque are also ensured at low battery charging levels. You can simply and quickly switch from the fast gear for run down to the power gear for reaching the shut-off torque. Each gear has eleven torque values to choose from.



*all torque values depend on model

High Performance Li-Ion Rechargeable Battery Pack



A full charge of the battery pack ensures approx. 180 boltings in a row (model ABG1400). With the second battery pack included, the number of boltings can be doubled without interruption. Smart electronics prevent depth discharge of the cells. The charging level can be checked any time directly on the battery pack.

AcraDyne Charger Station

Intelligent battery charging technology ensures rapid charging. Overload protection and the cooling function provide for a long battery life.



Accessories

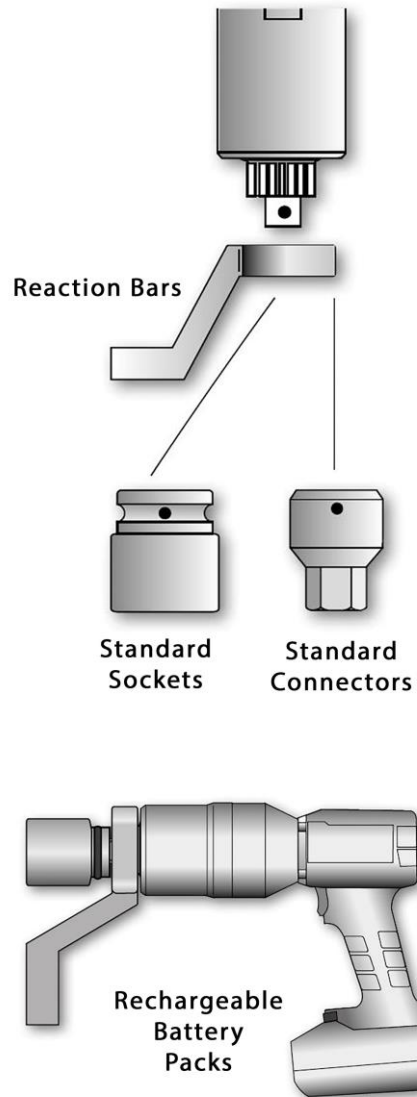

1. Technical Data

AcraDyne Li-Ion rechargeable battery pack:
 Voltage 18 V, 5.2 Ah
 Charging time approx. 100 min.

AcraDyne charger station:
 220-240 V / 50-60 Hz / 65 W
 Output 12-42 V / 3.0 A max (optional 110 V / 50 Hz)

2. Safety Instructions

2.1 Intended Use

The AcraDyne ABG Nutrunner has been designed for continuous tightening and loosening of heavy duty nuts and bolts. The power supply must be only through AcraDyne Li-Ion rechargeable battery packs. Other types of rechargeable batteries may cause fires or physical injury. The AcraDyne charger station has been dimensioned exclusively for charging AcraDyne Li-Ion rechargeable battery packs.

Any other use is considered improper. Any damages resulting from improper use are the responsibility of the user.

2.2 Operator Responsibilities

The user is obliged to read the operating and maintenance instructions before using or servicing the device. The device must only be used by persons aware of the purpose, the consequences of their action, and the precise usage of the device. Users must not be under the influence of intoxicating substances, e.g. drugs, alcohol, medication.

For further information on the safety measures and applications, please contact your AcraDyne partner.



Incorrect or improper use, or operation by unqualified personnel can result in severe physical injury and material damage.



The user is responsible for any third parties accessing the work zone.



The AcraDyne charger station must not be used in areas with an explosion hazard rating. Always observe the locally applicable and relevant safety instructions.



Independent modifications or changes on the product are not permissible.

2.3 Hazard notices



In case of mechanical or electrical damages to the Li-Ion battery pack or the charger station, the use of the specific device must be interrupted immediately. The damaged unit must be inspected for mechanical or electrical damages and safety. Defects must be repaired by qualified personnel and before renewed use.

Before repairing mechanical or electrical components or devices always disconnect the rechargeable power pack and the mains power supply from the power supply to the power tool.



Protect rechargeable battery packs (1) against dampness and wetness and do not subject to open fire.



Do not use deformed or defective battery packs. Do not attempt to open battery packs. Do not touch or short battery pack contacts. Keep away from small metal objects that could cause an electrical short between contacts. A short circuit can cause fire and physical injury through burns.



A slightly acidic and flammable liquid may seep out of defective Li-Ion rechargeable batteries. If the battery liquid comes into contact with human skin immediately rinse with plenty of water. If battery liquid comes into contact with an eye, immediately rinse and wash with plenty of water and consult a physician.



Do not attempt to charge non-rechargeable batteries. Doing so could cause an explosion.



Do not recharge fully charged batteries!



Do not use the charger station outdoors. Protect the charger station against dampness and wet.

Keep children away from the charger station and the work area.



In case of smoke or fire from the charger station immediately pull out the electric mains supply plug.

Do not insert objects in the ventilation slots of the charger station. This could result in electric shock or short circuit.

3. Operating the Charger Station



The charger station must only be used if the mains electrical supply matches the voltage and frequency specifications on the charger label. The charger station is an electrical device creating a direct current, which can trip simple residual current circuit breakers (RCCB). Use type F or better, with a trigger current of no more than 30 mA.



Before using the charger station, ensure that the ventilation slots are not covered or blocked. Minimum distance to other objects should at least 5 cm (2 in).

3.1 Self-Test

Plug the main plug into a suitable outlet. The warning indicator (4) and the operation indicator (3) will light up in sequence for approx. 1 second; the built-in fan will run for approx. 5 seconds.



Operation indicator

Warning indicator

3.2 Starting

Charging: Push rechargeable battery pack (1) completely onto the seat (2). The operating indicator will start to flash.



To check the charging level of the battery pack, first remove the pack from the charger, then push the button on the battery pack.

Trickle charging: If the battery pack is fully charged, the charger station will switch automatically to trickle charging. The battery pack can be left in the charger and ready for use any time. The operating indicator (3) will remain lit.



Fault: The warning indicator (4) is lit permanently; the battery pack is not charged. This is due to the temperature being too high or too low. Once the battery pack temperature is between 0° C and 50° C (32° F and 122° F) charging starts automatically.



If the warning indicator (4) flashes, check to see that the battery pack is seated correctly, or check if the battery pack is defective. Immediately remove the battery pack from the charger.



4. Operating the AcraDyne ABG Nutrunner



The ABG Nutrunner must not be damp or wet, and may not be used in a damp or humid environment. Always provide rain protection. Before first use, always fully charge the battery pack. Before any later use, always check the charge status of the battery pack and recharge, also in case of power decrease.

4.1 Starting

4.1.1 Remove, Charge, Insert, or Change Li-Ion Battery Pack

Remove battery pack

Push safety catch (5), and pull battery pack to the front (6).

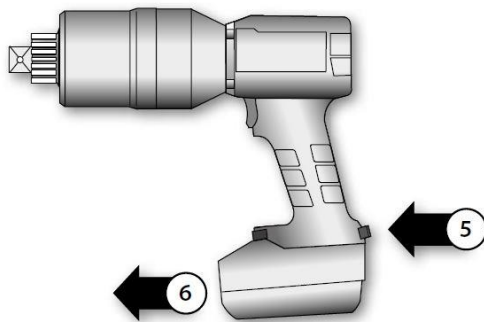

Charge battery pack

Push the battery pack completely onto the seat of the charger.



Insert battery pack

Push the battery pack all the way into the battery seat of the power tool (7), until the safety catch locks audibly.

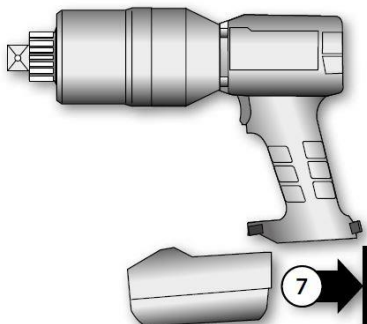

4.1.2 Battery Pack, Capacity, and Signal Display*



Push button (8) on the battery pack and check the charge status. If the battery pack is almost empty, it must be recharged. Replace the battery pack on the power tool.

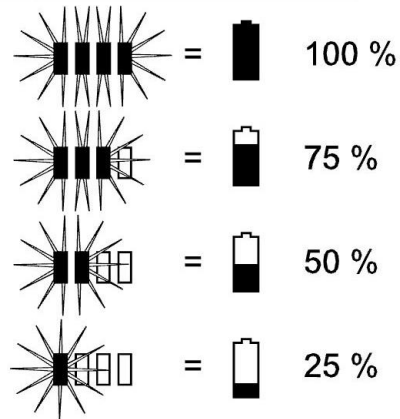
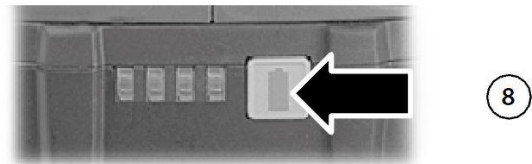

If one of the LEDs flashes, the battery pack is almost empty. The electronic circuitry protects the battery pack against damage due to complete discharge. Replace battery back on the power tool. Recharge battery pack.

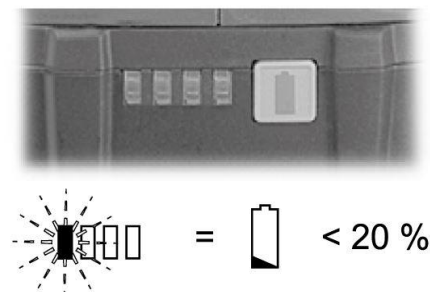

* Charge status indicators are approximate and may be slightly different, depending on the battery pack type.

4.2 Preparing for Work with the Power Tool



CAUTION!

Before preparing the power tool for work remove the Li-Ion battery pack from the tool.

Depending on the specific job, various adapters for tightening and loosening of bolted connections are needed.

- Place the ABG Nutrunner on a flat surface.
- If the reaction torque absorber is fitted with a safety screw, completely remove this screw (the position of this screw varies between the tool types).
- Push the reaction bar (9) onto the gear cogs (10).
- Tighten the safety screw completely to secure the reaction bar.

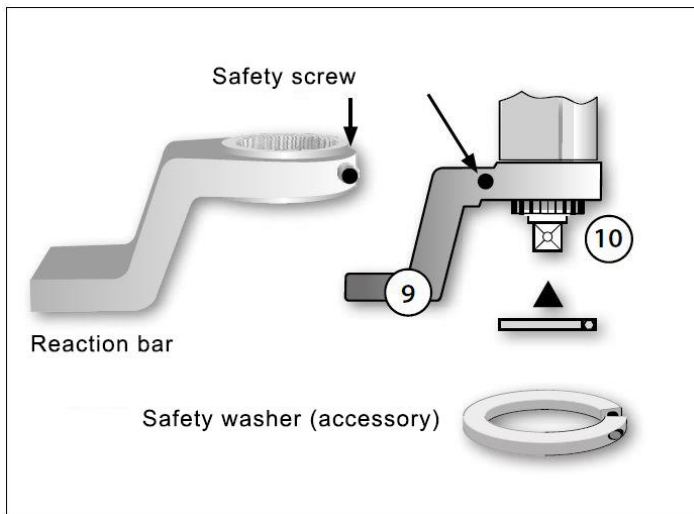

For reaction bars without safety lock, a safety washer is available as an accessory. This washer prevents a loosening of the reaction bar and can be pushed over the gear cogs and screwed tight.

- Push the socket/connector (11)/(12) onto the square drive (bore holes of the adapter and of the square must be aligned).
- Insert safety pin (13), secure with rubber ring (14) and completely tighten connector safety screw (15).

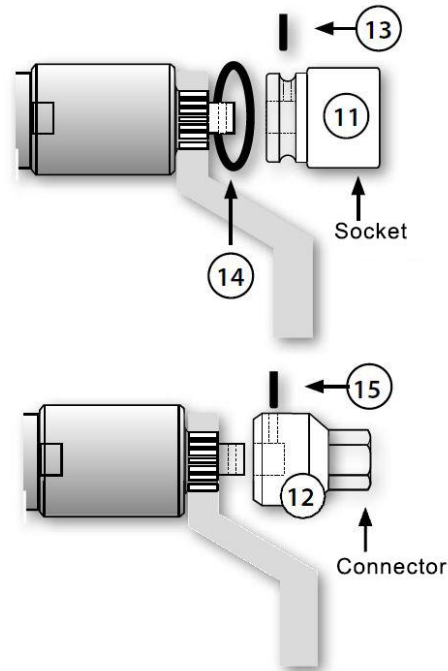

5. Electric operation

5.1 Switching on / off

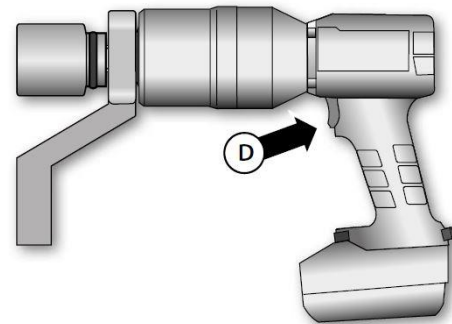

Switch on: Push and hold button (D). The electronic control system will ensure a soft start.

Switch off: Release button (D).

Note: The noise that is emitted during startup is due to the construction of the tool and has no influence on the function or longevity of the machine.



CAUTION!

Never block the rocker switch. This would make proper operation impossible.

5.2 Direction of Rotation, Transport Lock

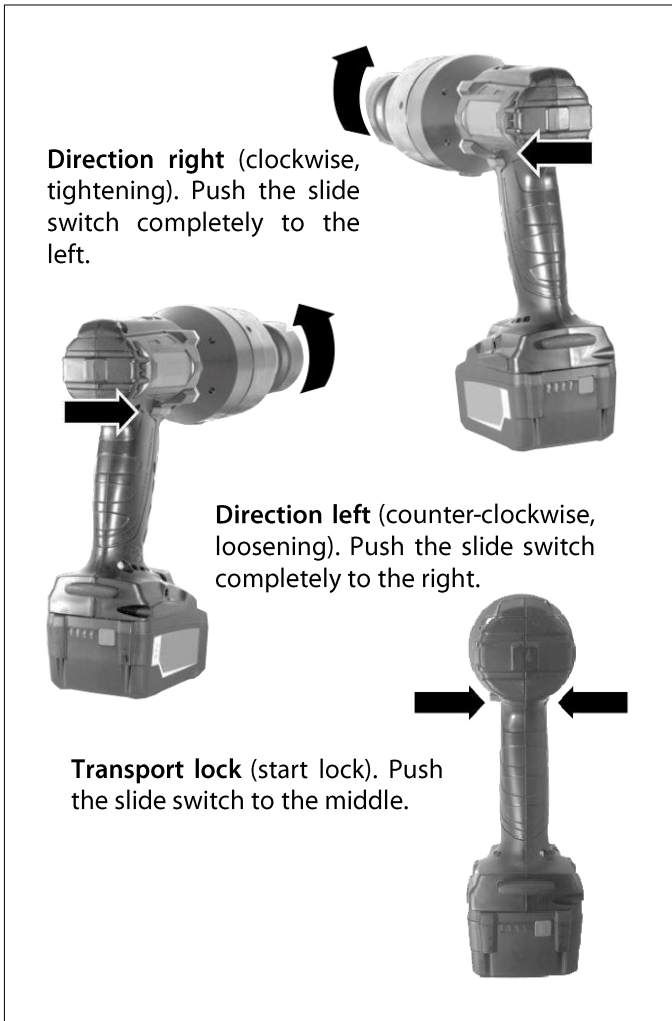

Direction right (clockwise, tightening). Push the slide switch completely to the left.

Direction left (counter-clockwise, loosening). Push the slide switch completely to the right.

Transport lock (start lock). Push the slide switch to the middle.

5.4 Setting the Shut-Off Torque

Setting the torque is done by means of the torque table on the tool or according to the standard torque chart included.



Machine-specific torque values can be compiled and documented on request by the AIMCO calibration lab.

NOTE!

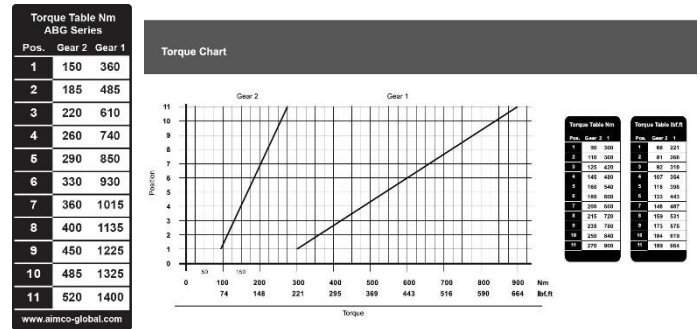

Torque table

Torque chart (sample)

In the torque table, each position number is assigned a respective torque. The shut-off torque is set by means of the setting wheel (SR) using the position number (1–11) (Fig. 1).

- The selection of the shut-off torque is done by means of the setting wheel, with 11 settings per gear (values 1-11 according to torque table).
- **Position 12** will provide the full torque available for loosening bolts and nuts.

When the set torque value has been reached, the tool will switch off precisely and an audible signal (beep) will sound. Actuate the slide switch only when the motor is stopped.

5.3 Gear Change (Rapid Mode / Power Mode)



Actuate the slide switch only when the motor is stopped.

Gear 2 ← **Gear 1**



In order to optimize the bolting cycle, it is recommended to start in gear 2 (fast) and then, depending on the required torque, switch to gear 1 (power gear) until the stopping point. See also section 5.4 Setting the Shut-Off Torque.

Precision shut-off torque
Align the arrow on the tool case with the required position number on the wheel.

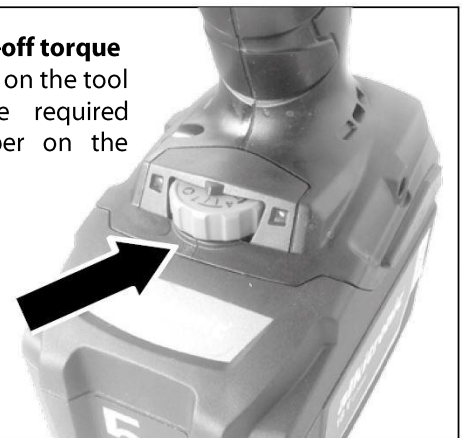

Fig. 1

6. Mechanical Operation

6.1 Safety Instructions for Tightening and Loosening



Always observe local regulations and directives when starting the tool. Always inspect power tool to make sure that it can safely function. Never work with damaged tools or objects.



Beware freely rotating accessories. Loose garments, long hair, cables, etc. must be kept outside the danger zone / rotation range.

The ABG Nutrunner must never be operated without supervision. Immediate stopping must be possible at all times. Observe safety distances.

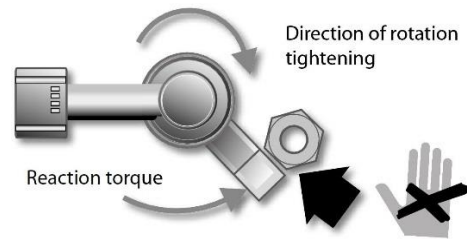

Never reach between reaction bar and support point. Doing so presents a high risk of injury.

6.1.1 Tightening and Loosening

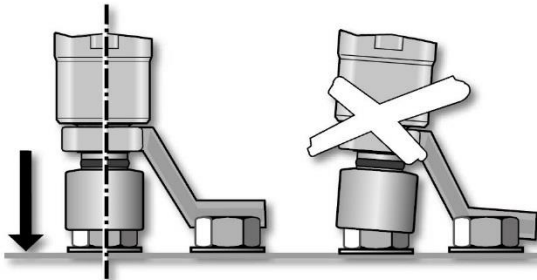

Always place the **socket/connector** completely and safely on the bolt/nut. The support of the reaction bar to absorb the reaction torque must always be safe and stable. Please consult your AIMCO partner for customized reaction bar solutions.



An incomplete or incorrect connection or support will lead to the following when bolting:

- Possible overload fractures of the **socket/connector**, gear and even drivesquare
- Incorrect torque application
- Contusions or severe injuries caused by spun-off parts or splinters.



Improper usage may also render all warranties null and void.

Work steps

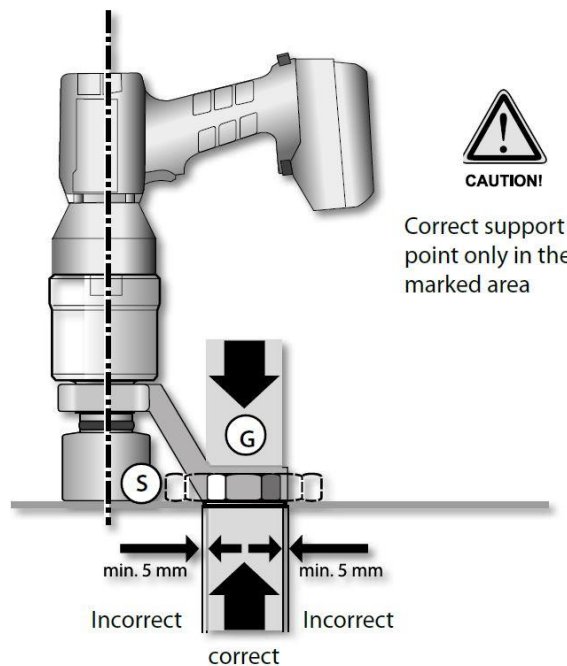

- Place the ABG nutrunner with socket/connector onto the bolt/nut.
- The reaction bar must absorb the reaction torque on the level of the socket/connector (S); a stable abutment (G) must be provided.
- Always hold the nutrunner perpendicular over the bolt axis.
- Start bolting action.
- The tool will stop as soon as the set shut-off torque or entered value has been reached.

Before moving to the next bolt / nut:

- If the torque multiplier cannot be pulled off the bolted joint (torsional forces caused), change the direction of rotation and switch the tool on and immediately off again to release the tool.

7. Function and Operation Test

7.1 Visual and Mechanical Inspection



Battery packs, charger station, operating and display elements, case and accessories, such as reaction bars, must be regularly inspected for damages and must be replaced professionally if necessary.



Do not obstruct ventilation opening. Soiled or blocked ventilation openings can cause malfunction and damage to the motor.



In case of reduced power, strong gear noise, or obvious severe damage, immediate repair is necessary. Please send all devices to be repaired in their original packaging to your nearest AIMCO partner.

8. Servicing / Storage / Maintenance

8.1 Replacing Accessories

See section 4.2 Preparing for Work with the Power Tool. Follow steps in the opposite direction.

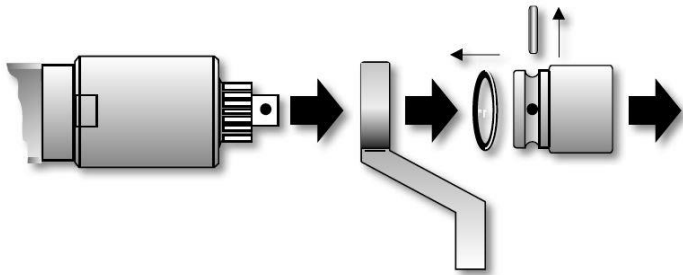

8.2 Storage in Lockable Containers



Store ABG Nutrunners and the charger station in a dry and cooled-off state in the original case, or in any other closable container. Heat and moisture lead to oxidation of the gear and other components inside the case. This can cause the tool to malfunction and can cause damage to the electronic circuitry and motor. When storing, ensure that the charger station power cable is not squeezed anywhere or damaged in any way.

Notes for the Li-Ion rechargeable battery pack



Always remove the battery pack from the power tool when not in use. Do not touch or short the contacts. Although the electronic circuitry will protect the battery packs against complete discharge, a long life is best ensured by maintaining a sufficient charge in the battery pack.

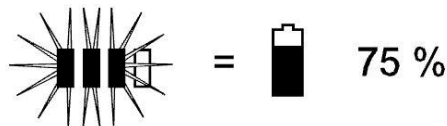

LED display on the battery pack



In order to maintain the battery pack in a fully charged state, a trickle charge of about 70 to 75% is required (see illustration above).

8.3. Decommissioning



If the AcraDyne tools and devices are not used over an extended period of time, they should be cleaned and stored in a dry and closable space that is inaccessible to children. The optimum storage temperature is between 10° and 30° C (50° and 86° F). Rotating components must be protected against oxidation (see Section 8.2).

8.4 Service and Maintenance



The ABG Nutrunner is an extremely powerful and robust product. To ensure long life and reliability over many years, the machine must be serviced at regular intervals (performance check, motor check, safety inspection, and calibration service).

Service intervals

The power tool must be inspected at least once per year. In the case of high usage or excessive operating hours, servicing and calibration will be necessary more frequently. In the case of unusual gear noises, a gear lubrication is urgently recommended to prevent subsequent damage.

AcraDyne ABG Nutrunners must always be packed in the original packaging when sending items in to your AIMCO partner or AIMCO.

9. Technical Notes

9.1 Safety Shut-Off



In order to prevent faulty boltings or damages to the power tool, the AcraDyne AGB Nutrunner is fitted with a multi-functional monitoring system.

If the machine switches itself off, the electronic system has activated the self-protection mode. There is an audible warning (30-second tone or until the push button (D) is released) (Fig. 3).



Fig. 3



Fig. 4

9.2 Causes and Problem Solving

Battery pack almost empty

The electronic system protects the battery pack against complete discharge.

If the LED display (L, Fig. 4) flashes, the battery pack is almost empty. If necessary, press the button on the battery pack (8, Fig. 4) to check the charge state. If the battery pack is almost empty, it must be recharged.

See also Section 4.1.2 Battery Pack, Capacity, and Signal Display

Excessive temperature

Overheating of the power tool over an extended period of time will result in temperature switch-off. The tool or the battery pack must be cooled down.



If the battery pack is very warm to the touch, it is recommended to cool it in the charger station. The motor will cool down quicker in idle mode.

Excessive current increase

The power tool switches off automatically.

If the current increase is quick (such as when there is a sudden blockage or seizing) the tool is switched off. Switch off the power tool on the push button (D, Fig. 3). Then restart and continue working normally. Prevent further blockages.

10. Noise Level and Vibration

Permanent noise level measured at maximum idle speed: 76 dB(A)

Noise emissions were measured at various working cycles. The distance of the sound sensor was 1 m from the geometric center of the power tool.

Vibration: medium until just before reaching the preselected torque.

11. Environmental protection

Do not immerse battery packs in water.



Protect the environment and do not dispose of electrical power tools and battery packs in normal household waste. Observe national regulations regarding recycling, and separation of unusable machinery, accessories, and packaging. Secure the contacts against shorts (e.g. cover with PTFE).

Materials and specifications are subject to change without notice



WWW.AIMCO-GLOBAL.COM

ISO 9001: 2015 Certified

CORPORATE HEADQUARTERS

10000 SE Pine Street
Portland, Oregon 97216
Phone: (503) 254-6600
Toll Free: 1-800-852-1368

AIMCO CORPORATION DE MEXICO SA DE CV

Ave. Cristobal Colon 14529
Chihuahua, Chihuahua. 31125
Mexico
Phone: (01-614) 380-1010
Fax: (01-614) 380-1019

AIMCO EUROPE

C/ Rio Gallo, 431 urb. Montelar
19174 Galápagos / Guadalajara
Spain
Phone: + 34 673 34 99 25

AIMCO CHINA

Room 607, No. 3998 Hongxin Rd
Minhang District, Shanghai
China
Phone: 0086-21-34319246
Fax: 0086-21-34319245

AIMCO SOUTH AMERICA

Carrera 29A, #7B-91 Origami Building Int604
Medellin; Colombia 050021

AIMCO SOUTH KOREA

B-1213, 167, Songpa-Daero
Songpa-Gu, Seoul 05800
South Korea
Phone: 0082-2-2054-8930
Cell: 0082-10-9804-8905