ALPHA-T42 ~ T62 and UBP-7 & T7 Pulse Unit Repair Manual



Contents

	<u>Page Number</u>
1. Recommended Tools	2
2. Repair Fixtures	3-4
3. Disassembly and Reassembly of the Pulse Unit	5-10
4. Fill & Draw Sheet	11
5. Exploded View of the Pulse Unit	12-13
6. Recommended Maintenance	14

Recommend Tools

- | | |
|---|--|
| 1. One Set T-handle Metric Allen Wrenches | 15. Arbor Press |
| 2. Flat-Bladed Screwdrivers | 16. VC-101-2A Vacuum Tank |
| 3. 10 oz. Ball Peen Hammer | 17. VCE-1-1 Vacuum Extractor |
| 4. One Set Pin Punches | 18. Two Torque Wrenches 0-200 ft. lbs. |
| 5. One Set O-Ring Picks | 19. Universal Repair Fixture |
| 6. 6" Adjustable End Wrench | 20. SPF-Oil Pulse Unit Fluid |
| 7. 12" Adjustable End Wrench | 21. O-Ring Installation Tools |
| 8. Medium Pair Channel Locks or Adjustable Jaw Pliers | 22. Removal of Air Motor Connector (A-T42 through A-T62) |
| 9. Medium Honing Stone | 23. Auditor Series Monitor and Transducers with the UFT-S10 Joint Simulators |
| 10. 220 Grit Wet/Dry Sandpaper | 24. Needle Nose Pliers |
| 11. Lap Plate | 25. Propane Torch |
| 12. Loc-Tite #242 | 26. Teflon Seal Setter |
| 13. CFC Free Degreaser-Cleanser | |
| 14. Loc-Tite Accelerator | |

Pulse Unit Repair Fixtures

ALPHA-T42 ~ T62 and UBP-7 & T7

Fixture for Setting Anvil O-Ring

Part Number	Tools Used With		
178-319-8-1	ALPHA-T47	ALPHA-T52	ALPHA-T62
178-350-9-2	ALPHA-T42D	ALPHA-T52D	ALPHA-T62D

Fixture for Holding & Pressing in the Accumulator

Part Number	Tools Used With			
150-972-5-1	ALPHA-T47	ALPHA-T52	UBP-7	UBP-T7

Fixture for Disassembly & Reassembly of Casing Connector

Part Number	Tools Used With			
177-036-6-5	ALPHA-T42	ALPHA-T47	ALPHA-T52	ALPHA-T62

Vacuum Filler Tank

Part Number	Tools Used With
VC-101-2	All Models

Pulse Unit Fluid

Part Number	Tools Used With
SPF-Oil	ALPHA-T42~T62 and UBP-T7 Series only

Pulse Unit Repair Fixtures

Fixture Set-In O-Ring

Part Number	Tools Used With			
990-320-0-1	ALPHA-T42, T47	ALPHA-T52	ALPHA-T62	UBP-T7
990-971-0-1	ALPHA-T42, T47	ALPHA-T52	ALPHA-T62	UBP-T7
990-972-0-1	ALPHA-T42, T47	ALPHA-T52	ALPHA-T62	UBP-T7

Fixture for Placing Anvil C/W Driving Blades into Liner

Part Number	Tools Used With			
190-440-6-1	ALPHA-T42	ALPHA-T47	ALPHA-T52	ALPHA-T62
190-440-6-0				

Universal Pulse Unit Repair Fixture

Part Number	Tools Used With
PTRF-1-1	All Models

Vacuum Extractor

Part Number	Tools Used With
VCE-1-1	All Models

Disassembly and Reassembly of the Pulse Unit

ALPHA-T42 – T62 and UBP-7 & T7

A. Disassembly of Pulse Unit

1. Remove the front casing from the tool. This is a left-hand thread on all but the UBP-7 and UBP-T7.
2. Turn the Torque Adjuster in until it stops. On the UBP-7 and T7, turn the Accumulator counter-clockwise until it stops.
Note: This is a left-hand thread. Remove the Hexagon Round Head Plug inside the Rear Liner Plate on the UBP-T7.
3. Remove the Oil Fill Plug and vacuum the oil out of the Pulse Unit with the VCE-1-1 Vacuum Extractor.
4. Set the Liner Casing Setter, located at the rear of the Pulse Unit, onto the correct size pins in the blocks of the setter. **Note:** This is left-hand thread.
5. Place the Pulse Unit assembly onto the correct size base plate and between the clamp plates of the PTRF-1-1. Run the press rod down into the setter and secure it with the lock nut; it is not necessary to put any pressure on the press rod. Tighten the clamp screws securing the Pulse Unit.
6. Set a 1/2" breaker bar into the setter; this is a left-hand thread indicated by an arrow on the Liner Casing Setter.
7. Loosen and remove the Liner Casing Setter. Remove the Pulse Unit from the repair fixture.
8. Remove the Rear Liner Plate.
 - a) If suction is too great, tap the drive end of the Anvil on bench and loosen Rear Liner Plate.
 - b) Remove the two locator pins from the rear of the Liner.
 - c) Remove the Accumulator and Spacer from the Rear Liner Plate. On the ALPHA-T42 through T62, remove the Spring Washer. On the UBP-7 and T7, unthread the Accumulator clockwise. **Note:** This is a left-hand thread.
 - d) Remove the Torque Adjuster, Spring, and Ball from the Rear Liner Plate.
 - e) Remove the Relief Valve and Pin from the Rear Liner Plate.
 - f) Remove the Snap Ring, Spacer, O-Ring, and Piston from the rear of the Rear Liner Plate. On the UBP-7, remove the Polyurethane Rubber in the Rear Liner Plate.

Disassembly and Reassembly of the Pulse Unit

9. Rotate the Anvil until the bevel lines of the Anvil are parallel with the contacting lines inside the Liner. Push the Anvil and Driving Blades out of the Liner.
10. Remove the Front Liner Plate and Liner from the Liner Casing. **Note:** You may have to tap the rear of the Liner Casing on the bench to remove the Front Liner Plate.
11. Remove the two Locator Pins in the front of the Liner.
12. Remove all O-rings and Supporter Rings from the parts. Remove the Anvil, O-ring or Teflon seal and Supporter ring located inside the Liner Casing.

B. Inspection

1. Front Liner Plate

- a) If light scarring on plate surface is present, resurface on Lap Plate in a figure eight motion with 220 grit sandpaper (wet or dry) using honing oil as a buffer. **Note:** All markings must be removed.
- b) If heavy scars or burring are present and cannot be resurfaced smooth, replace parts as needed.

2. Rear Liner Plate

- a) Do not resurface. There will be a seating mark from the Anvil, and when this gets deeper than .05 mm in depth, replace the part.
- b) The Spacer for the Piston should not be larger than 5mm in inside diameter.

3. Liner Casing Setter

- a) Wire wheel outer threads to remove old Loc-Tite.
- b) Resurface bottom setting surface (level) using Lap Plate and 220 grit sandpaper.

4. Driving Blades

- a) Check the contour surface of the blades for scars or burring.
- b) If driving blade is scarred below the contour surface, fluid will pass underneath the blade at contact points, resulting in inaccurate pressure in the Liner and low torque output.
- c) If there is heavy scarring (cuts below contour surface) replace it.

Disassembly and Reassembly of the Pulse Unit

- d) Light scarring on contour surface is normal wear. Clean surface on Lap Plate by lapping the length of the blade and roll with the contour.
 - e) Light horizontal grooves on side of blade is normal wear.
 - f) Check plate ends of the blade for grooving. If heavy grooving is present, always replace the blades as a set.
5. **Liner**
- a) Inspect inner horizontal and vertical blade seats for scars and burring.
 - Light scarring is normal wear.
 - Heavy scars will cause the fluid to pass by the driving blade, and the Liner will not produce accurate pressure for torque output. Replace.
6. **Torque Adjuster/Relief Valve**
- a) Check the Adjuster for straightness; also check Allen end for cracking, damaged, or stripped threads. If damage is present, replace.
 - b) Check Ball seat for oblonging.
7. **Liner Casing**
- a) Check for internal scars and burring.
 - b) Check internal threads for burrs.
8. **Anvil**
- a) Check plate surface of Anvil. If light scarring or uneven wear is present, resurface with medium oil stone using honing oil as a buffer.
 - b) If heavy scarring is present and cannot be resurfaced smooth, replace Anvil.
 - c) If chips or cracking are present, replace Anvil.
 - d) If uneven wear from socket is present, replace Anvil.
 - e) Check Anvil at contact point with O-ring or Teflon Seal. If there is an indentation present on the Anvil at this point, the Anvil should be replaced.
 - f) Check the Anvil for scarring from Anvil bushing. If heavy scarring is present, replace Anvil.
9. **Thoroughly clean all parts and blow dry.**
10. **Replace all O-rings, Springs, and Supporter Rings.** This can be easily done by purchasing a Pulse Unit Repair Kit.

Disassembly and Reassembly of the Pulse Unit

C. Reassembly

1. Using a blow gun, clean parts of any remaining solvent or lint.
2. Install O-rings onto the Torque Adjuster, Relief Valve, and Oil Fill Screw.
3. Install the O-ring, Spacer, and Snap Ring into the rear of the Rear Liner Plate. Install the Relief Valve and Pin into the Rear Liner Plate. Install the Ball, Spring, and Torque Adjuster into the Relief Valve in the Rear Liner Plate. **Note:** Turn the Torque Adjuster all the way in a clockwise direction.
 - a) On the UBP-7 and T7, thread the Accumulator onto the Rear Liner Plate counter-clockwise until it stops. **Note:** This is a left-hand thread.
 - b) Set the Rear Liner Plate onto a 6mm Allen Wrench. Install the two short Locating Pins and the Liner. **Note:** The Liner has no top or bottom.
4. Install Driving Blades and Springs into Anvil. Place in Driving Blade Setter.
5. Install Anvil and Driving Blades into Liner.
6. Install the two long Locating Pins into the Liner and install the Front Liner Plate. On the UBP-7 and T7, install the Anvil Rear Spacer first and the Anvil O-ring into the Front Liner Plate.
7. Install Rear Plate O-ring.
8. Install the Anvil Sleeve for the Anvil O-ring; this is not needed on the UBP-7 and T7. **Note:** There is an Anvil Sleeve for the 1/4" hex Anvil and the 3/8" square Anvil.
9. Install the Teflon Seal into the front of the Front Liner Plate; this is not used on the UBP-7 and T7.
10. Install the Liner Casing and make sure you line up the holes in the Liner Casing with the Oil Fill Screw hole and Torque Adjuster hole in the side of the Liner Casing.
11. Install the O-ring onto the Accumulator Spacer and install into the rear of the Liner Casing and over the Rear Liner Plate, O-ring first. Install the Spring Washer on the ALPHA-T42 through T62 over the Rear Liner Plate. Install the O-rings onto and into the Accumulator and install into the rear of the Liner Casing and over the Rear Liner Plate, O-ring side first. **Note:** The Accumulator threads

Disassembly and Reassembly of the Pulse Unit

- into the Rear Liner Plate on the UBP-T7.
- Clean all oils from the threads of the Liner Setter and Liner Casing. Lightly coat the threads with a good cleaner/degreaser. Put a light coat of a good quality thread locker on the threads of the Liner setter and thread it into the Liner Casing.
 - Set the Liner Casing Setter, located at the rear of the Pulse Unit, onto the correct size pins in the blocks of the setter. **Note:** This is a left-hand thread.
 - Place Pulse Unit assembly onto the correct size base plate and between the clamp plates of the PTRF-1-1. Run the press rod down into the setter and secure it with the lock nut. It is not necessary to put any pressure on the press rod. Tighten the clamp screws securing the Pulse Unit.
 - Set a 1/2" torque wrench into the Setter and tighten the Liner Setter to the recommended torque shown on the chart.
 - Remove the Pulse Unit from the repair fixture.

D. Fluid

- Recommended fluid is AIM/Uryu Pulse Unit Fluid, part number SPF-OIL.

E. Filling Procedure

- Turn the Torque Adjuster out counter-clockwise until it stops. Turn the Accumulator out clockwise until it stops on the UBP-7 and T7.
- The Pulse Unit is now set for maximum fill. Any measurable change in fluid level will affect the torque output and the consistency of the tool.
- Put the Pulse Unit in the Vacuum Tank, Anvil-side down, with the rear of the Pulse Unit up to purge all air out of the Pulse Unit.
- Follow the fill procedures as outlined in the Operations Manual for the VC-101-2 Vacuum Tank.
- Before removing the Pulse Unit from the Vacuum Tank, install the Piston and make sure the Accumulator is all the way out while the Pulse Unit is under

Disassembly and Reassembly of the Pulse Unit

the Oil. Install the Polyurethane Rubber and Hexagon Round Head Plug on the UBP-7.

6. Putting your thumb over the Oil Fill hole, remove the Pulse Unit out of the Vacuum Tank and set it on its side into the Fixture to press the Accumulator.
7. Press the Accumulator in and install the Oil Fill Plug. On the UBP-7 and T7, turn the Accumulator counter-clockwise until it

stops. Install the Oil Plug and turn the Accumulator out clockwise until it stops.

8. You are now ready to test the Pulse Unit. **Note:** If the Unit does not come up to torque, put it back into the Accumulator Jig and depress the Accumulator. Remove the Oil Fill Plug and rotate the Anvil until a few drops of oil come out. Install the Oil Fill Plug and test again.

F. Torque Adjustment

1. To properly adjust the torque, turn the Adjuster with a 2mm Allen wrench clockwise until the Adjuster Valve bottoms-out for maximum torque.
2. Reverse procedure for minimum torque.

ALPHA-T42 ~ T62 and UBP-7 & T7 Series
Fill & Draw Sheet

Key Model of this Tool Group	Full Volume of Liner Oil in Pulse Unit (approx.)	Volume to be Removed from the Full Volume (approx.)	Torque to Tighten Liner Casing Setter (approx.)	Torque to Tighten Liner Casing Setter (approx.)	Load to Press on Rear Liner Plate	Load to Press on Rear Liner Plate
					Hydraulic Press	P.T.R.F.
Model	cc's	cc's	NM	Ft-Lbs	Tons	Ft-Lbs/Nm
ALPHA-T40D(S), T42D(S)(P), T45(S)(D)(P), T46(D), T47(S)(D)(P), T50(D) & T52(D)	5.0		70+/-5	52+/-4		
ALPHA-T60(D) & T62(D)(MI)	6.2		85+/-5	63+/-4		

Exploded View of Pulse Unit

ALPHA-T42 ~ T62

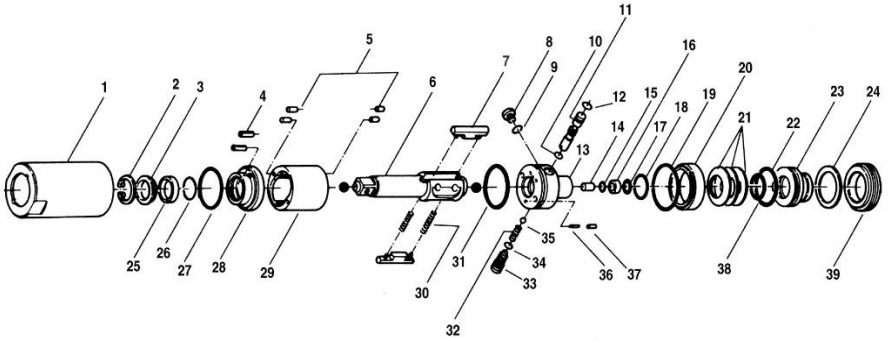

Part Number	Description	Part Number	Description
1	Liner Casing	21	Belleville Washers
2	Front Liner Plate Snap Ring	22	Accumulator O-Ring
3	Front Liner Plate Spacer	23	Accumulator
4	Roll Pin	24	Accumulator Buffer
5	Locator Pins	25	Anvil Supporter Ring
6	Anvil	26	Anvil O-Ring
7	Driving Blade	27	Front Liner Plate O-Ring
8	Oil Fill Plug	28	Front Liner Plate
9	Oil Fill Plug O-Ring	29	Liner
10	Relief Valve O-Ring	30	Driving Blade Spring
11	Relief Valve	31	Rear Liner Plate O-Ring
12	Relief Valve O-Ring	32	Relief Valve Spring
13	Rear Liner Plate	33	Relief Valve Spindle
14	Piston	34	Relief Valve Spindle O-Ring
15	Piston O-Ring	35	Relief Valve Ball
16	Piston Bushing	36	Relief Valve Pin
17	Snap Ring	37	Rear Liner Plate Plug
18	Adjusting Spacer	38	Accumulator O-Ring
19	Liner Casing Spacer O-Ring	39	Liner Casing Setter
20	Liner Casing Spacer		

Exploded View of Pulse Unit

UBP-T7 Pulse Unit

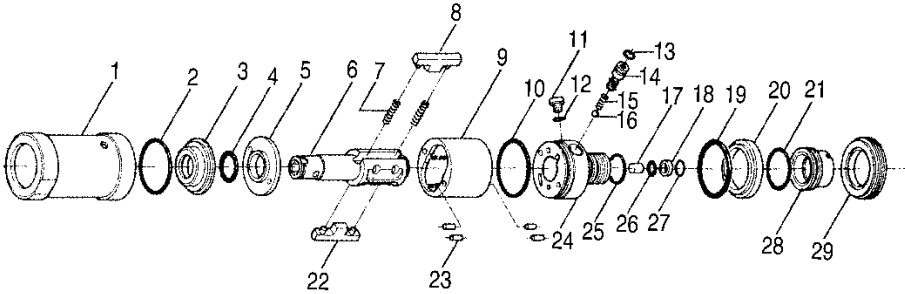

Part Number	Description	Part Number	Description
1	Liner Casing	16	Relief Valve Ball
2	Front Liner Plate O-Ring	17	Piston
3	Front Liner Plate	18	Piston Bushing
4	Anvil O-Ring	19	Liner Casing Spacer O-Ring
5	Anvil Rear Spacer	20	Liner Casing Spacer
6	Anvil	21	Accumulator O-Ring
7	Driving Blade Springs	22	Driving Blade
8	Driving Blade	23	Locator Pins
9	Liner	24	Rear Liner Plate
10	Rear Liner Plate O-Ring	25	Accumulator O-Ring
11	Oil Fill Screw	26	Piston O-Ring
12	Oil Fill Screw O-Ring	27	Snap Ring
13	Relief Valve O-Ring	28	Accumulator
14	Relief Valve	29	Liner Casing Setter
15	Relief Valve Spring		

Recommended Maintenance

Pulse Unit

The Pulse Unit Oil should be changed every 150,000 cycles and the Pulse Unit should be rebuilt and a repair kit installed every 300,000 cycles. Remember to always use genuine Uryu Parts and SPF-Oil Pulse Unit Fluid.



WWW.AIMCO-GLOBAL.COM

CORPORATE HEADQUARTERS

10000 SE Pine Street
Portland, Oregon 97216
Phone: (503) 254-6600
Toll Free: 1-800-852-1368

AIMCO CORPORATION DE MEXICO SA DE CV

Ave. Cristobal Colon 14529
Chihuahua, Chihuahua. 31125
Mexico
Phone: (01-614) 380-1010
Fax: (01-614) 380-1019

LIT-MAN390 Rev. 07/2020
Printed in USA ©2020 AIMCO