



Gen IV iBC-Z Controller Operation Manual



Table of Contents

1. Safety Information	3	4.7.4 Identify Controller	34
2. Controller Diagram	4	4.7.5 Record Logs	34
2.1 Bottom Panel	4	4.7.5.1 Change Log	34
2.2 Front Console LED Display	4	4.7.5.2 Information Log	34
3. Initial Setup	5	4.7.5.3 Error Log	34
3.1 Connecting to the Controller	5	4.7.5.4 All	34
3.2 Pairing iBC-Z Controller to Uryu UBX-AF Tool	8	4.7.6 System Status	34
3.2.1 Requirements	8	4.7.7 I/O Diagnostics	34
3.2.2 Pairing Procedure	8	4.7.8 Network Diagnostics	34
3.2.3 Problems Pairing	11	4.8 Login	35
3.2.4 PAN ID Tool Switch Settings	12	4.9 Advanced	35
4. Home Page (Main Menu)	13	4.9.1 Login Setup	35
4.1 Run	13	4.9.2 Results Archive	36
4.2 PSet	15	4.9.3 Import Settings	37
4.2.1 Add New PSet	15	4.9.4 Export Controller	37
4.2.1.1 Add New Stage	15	4.9.5 Update Controller	37
4.2.2 PSet Stages	16	4.9.6 Backup Restore	38
4.2.2.1 TC_PM Torque Control Pulse Monitor	16	4.9.7 Restore Factory Defaults	38
4.2.2.2 TC_APM Torque Control Angle Pulse Monitor	17	4.9.8 Previous Software	39
4.2.3 Edit PSet	18	4.9.9 Calibrate Touch Screen	39
4.2.4 Advanced Options	18	4.9.10 Soft Reboot	39
4.2.5 Default PSets	19	4.10 Statistics	39
4.2.6 Manage PSets	19	5. Barcode Reader Details	40
4.3 Job	19	6. Glossary of Terms	42
4.3.1 Add New Job	19	7. Icons Defined	43
4.3.2 Advanced Options	20	8. Stop Codes	44
4.3.3 Jobs "Enabled" Display and Button Function	20	9. Error Codes	45
4.4 Results	21	10. 24 Volt I/O	47
4.4.1 Saving Rundown(s)	22	11. Assignable I/O	49
4.5 Controller	23	12. Controller Supported MIDs	61
4.5.1 IO	23	13. Dimensions	62
4.5.1.1 Physical I/O	23	14. Specifications	62
4.5.1.2 Physical I/O Monitor	24	15. Troubleshooting	63
4.5.1.3 Anybus/Modbus TCP/Ethernet IP Inputs	25	15. AIMCO Warranty	64
4.5.1.4 Anybus/Modbus TCP/Ethernet IP Outputs	26		
4.5.2 Communication Interfaces	27		
4.5.2.1 Ethernet/Second Ethernet	27		
4.5.2.2 System Port	27		
4.5.2.3 Serial Port	27		
4.5.2.4 Anybus	28		
4.5.2.5 Spindle USB	28		
4.5.2.6 Serial USB	28		
4.5.3 Protocols	30		
4.5.4 Front Panel Buttons	30		
4.5.5 Power Up	30		
4.5.6 Bar Code Setup	30		
4.5.7 Set Time	31		
4.5.8 Remote Connections	31		
4.5.9 Lock Tool on Reject	32		
4.5.10 Tool Pairing	32		
4.5.11 Languages	32		
4.6 Accessories	32		
4.7 Diagnostics	32		
4.7.1 Controller Overview	33		
4.7.2 Controller Status	33		
4.7.3 Tool Communications	33		

1. Safety Information

General Power Tool Safety Warnings



WARNING

Read all safety warnings, instructions, illustrations, and specifications provided with this power tool. Failure to follow all instructions listed below may result in electric shock, fire, and/or serious injury.

Save all warnings and instructions for future reference.

1. Work area safety

- Keep work area clean and well lit.
- Do not operate power tools in explosive atmospheres, such as in the presence of flammable liquids, gases, or dust.
- Keep children and bystanders away while operating a power tool.

2. Electrical safety

- Power tool plugs must match the outlet. Never modify the plug in any way. Do not use any adapter plugs with earthed (grounded) power tools.
- Avoid body contact with earthed or grounded surfaces, such as pipes, radiators, ranges, and refrigerators.
- Do not expose power tools to rain or wet conditions.
- Do not abuse the cord. Never use the cord for carrying, pulling, or unplugging the power tool. Keep cord away from heat, oil, sharp edges, or moving parts.
- When operating a power tool outdoors, use an extension cord suitable for outdoor use.
- If operating a power tool in a damp location is unavoidable, use a residual current device (RCD) protected supply.

3. Personal safety

- Stay alert, watch what you are doing, and use common sense when operating a power tool. Do not use a power tool while you are tired or under the influence of drugs, alcohol, or medication.
- Use personal protective equipment. Always wear eye protection.
- Prevent unintentional starting. Ensure the switch is in the off-position before connecting to power source and/or battery pack, picking up or carrying the tool.
- Remove any adjusting key or wrench before turning the power tool on.
- Do not overreach. Keep proper footing and balance at all times.
- Dress properly. Do not wear loose clothing or jewelry. Keep your hair, clothing, and gloves away from moving parts.
- Do not let familiarity gained from frequent use of tools allow you to become complacent and ignore tool safety principles. A careless action can cause severe injury within a fraction of a second.

4. Power tool use and care

- Do not force the power tool. Use the correct power tool for your application.
- Do not use the power tool if the switch does not turn it on and off.
- Disconnect the plug from the power source and/or remove the battery pack, if detachable, from the power tool before making any adjustments, changing accessories, or storing power tools. Such preventive safety measures reduce the risk of starting the power tool accidentally.
- Store idle power tools out of the reach of children and do not allow persons unfamiliar with the power tool or these instructions to operate the power tool. Power tools are dangerous in the hands of untrained users.
- Maintain power tools and accessories. Check for misalignment or binding of moving parts, breakage of parts, and any other condition that may affect the power tool's operation. If damaged, have the power tool repaired before use. Many accidents are caused by poorly maintained power tools.
- Use the power tool, accessories, and tool bits, etc., in accordance with these instructions, taking into account the working conditions and the work to be performed. Use of the power tool for operations different from those intended could result in a hazardous situation.
- Keep handles and grasping surfaces dry, clean, and free from oil and grease. Slippery handles and grasping surfaces do not allow for safe handling and control of the tool in unexpected situations.

5. Service

- Have your power tool serviced by a qualified repair person using only identical replacement parts. This will ensure that the safety of the power tool is maintained.

6. Equipment Installation, Operation, and Maintenance

- Safety of any system incorporating the equipment is the responsibility of the system assembler
- Position the equipment so that it is easy to access the disconnecting device
- Do not replace main power cord with an inadequately rated cord
- Only allow your power tool to be repaired by a qualified technician using only original spare parts, available from AIMCO. This ensures that the safety of your device is maintained.

2. Controller Diagram

2.1 Bottom Panel

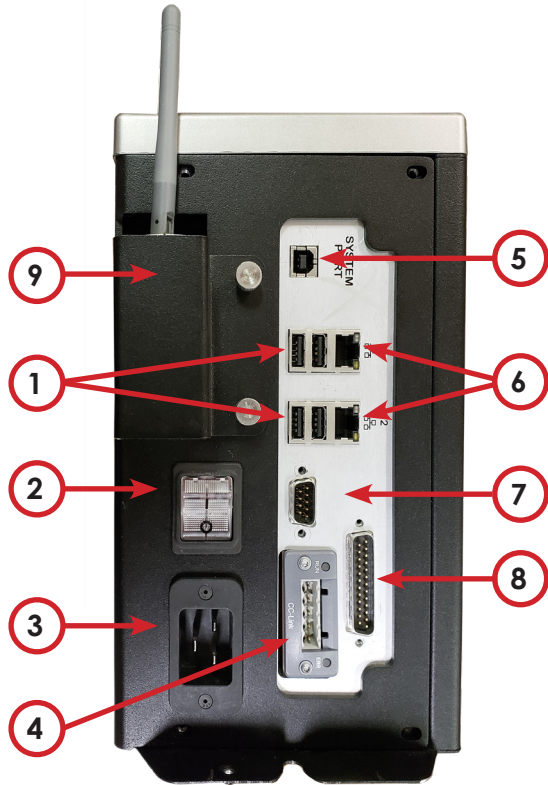

1	USB port-for import/export of data including firmware updates
2	Power Disconnect Switch-Turns controller on and off
3	Power Cord Connection
4	AnyBus Networking Cartridge (CC Link shown)
5	System Port- USB connection used to connect external computer to configure/monitor the controller
6	Ethernet Port RJ45- Connection used to connect external computer to configure/ monitor the controller
7	Serial Port (DB-9 Pin M) Serial data Output for communication with peripherals such as barcode readers and printers
8	24 Volt I/O Connector (DB-25 Pin M)- Input and output of signals for process control
9	URYU Uzig01 ZigBee Coordinator

2.2 Front Console LED Display

Indicator Lights

Green	Indicates fastening cycle meets specified parameters.
Red	Indicates fastening cycle rejected for exceeding high torque.
Red Flashing	Indicates low torque. Fastening cycle was rejected for not achieving low torque.
Yellow	Indicates High Angle. Fastening cycle was rejected for exceeding high angle.
Yellow Flashing	Indicates Low Angle. Fastening cycle was rejected for not achieving low angle.
Blue	Tool is In-cycle, above threshold.



Toggle Button
Toggles what is shown in the secondary display

Parameter Settings (PSet)/Job Display

Increment/Decrement Buttons
Change PSet

Torque Display
Always displays torque value

Secondary Display
Toggle button switches secondary display between

- Units of measure
- Ethernet IP address
- USB (System Port) IP address
- Angle report

NOTE: If Jobs are enabled refer to "4.3 Job" on page 19 for Toggle Button function.

3. Initial Setup

Step 1

Plug female end of power cable into Power Cable Connector (Figure 1, pg. 11).

Step 2

Plug male end of power cable into appropriate power source.

Due to a variety of 230Vac power outlets, the standard power cable plug-end provided with the controller may need to be modified in order to connect to local 230Vac power outlets. AcraDyne has a wide variety of country specific power cord options available. Check with your authorized AcraDyne representatives to see if your specific configuration is available. In any case, connection to local power should be made in consultation with a qualified electrician.

Step 3: The Redundant Earth Ground (required) must be connected to ground using the #14 AWG conductor, a green wire with a yellow stripe. Attach using a #10-14AWG ring terminal and #10 star washer (Figure 1).



Figure 1 — Redundant Earth Ground Attachment

Step 4: Turn controller on by pushing the Power Disconnect Switch to the POWER ON position, a light indicates power on.

3.1 Connecting to the Controller

There are three ways to program/communicate with the controller:

- Controller touch-screen console
- System Port: (USB connection) Direct connection to controller.
- Ethernet Port: Via direct connection or LAN.

Touchscreen Console

Controller functions and programming can be accessed directly through the touch-screen.

1. Power on controller.
2. Run screen will appear
3. Controller is ready for use.

Connecting via the System Port Directly to PC

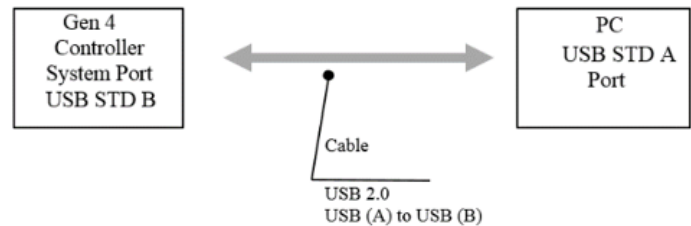

The following is an example using Window 7. Your screen may look different depending on the operating system.

Windows USB Setup

Step 1: Power on PC and controller, allow enough time for them to become fully operational.

Step 2: Attach controller to PC using a USB 2.0 A-B cable. If this is the first time connecting the devices, wait for Windows to install the RNDIS driver. This should happen automatically.

Step 3: After the driver is installed, go to 'Control Panel'.

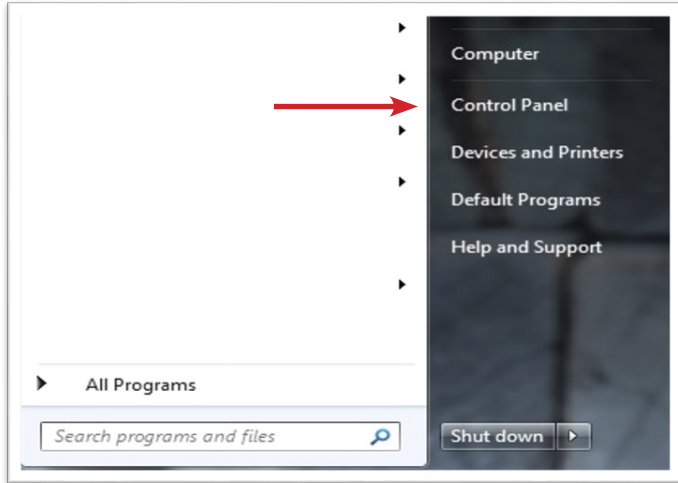

Step 4: Go to 'Network and Internet'.

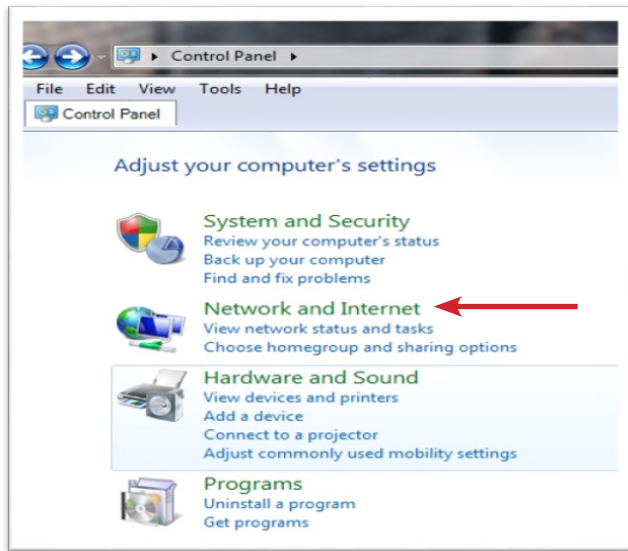

Step 5: Go to 'Network and Sharing Center'.

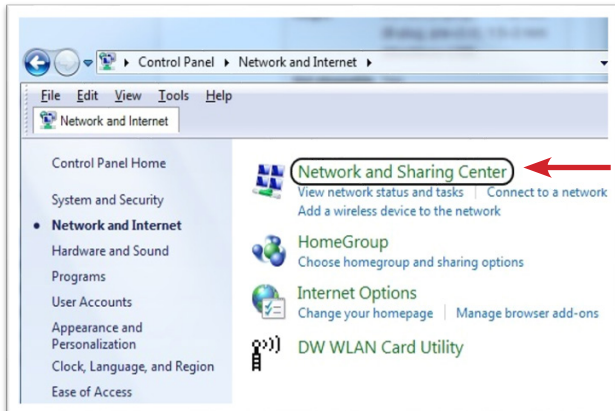

Step 6: Go to 'Change adapter settings'.

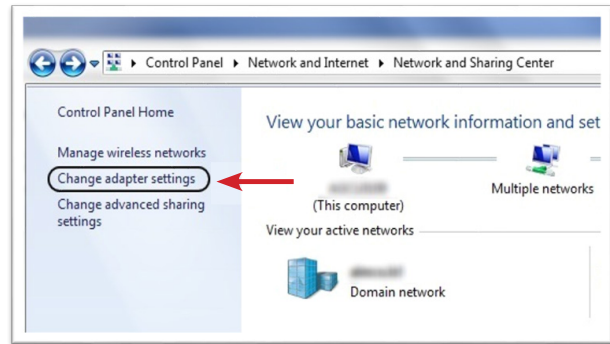

Step 7: Find the Local Area Connection that is using the 'USB Ethernet/RNDIS Gadget' network. Right click this network and go to 'Properties'.

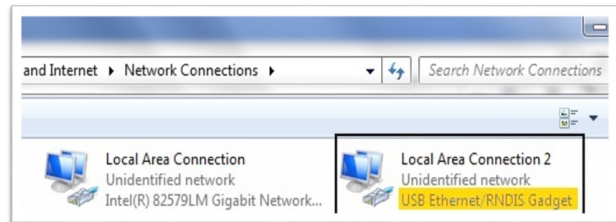

Step 8: In Properties window select 'Internet Protocol Version 4' and click 'Properties'.

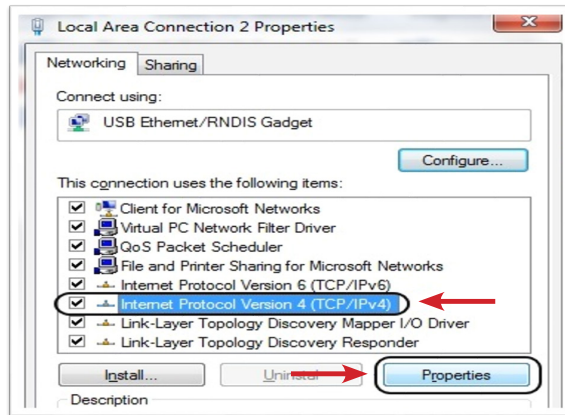

Step 9: In 'Properties', set the IP address to a static address.

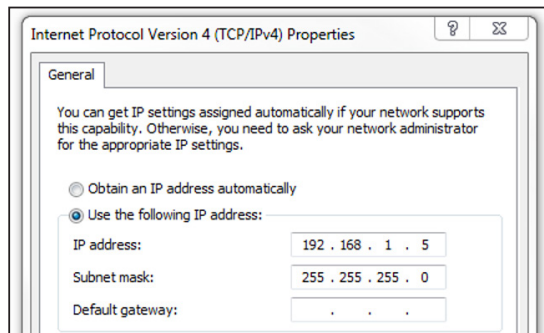

Type an IP address of 192.168.1.5 (Any address on the same subnet as the controller will work). Set subnet mask to 255.255.255.0

Step 10: To connect to the controller, open a browser such as Chrome or Firefox. Enter 192.168.1.4, the default system port IP address.

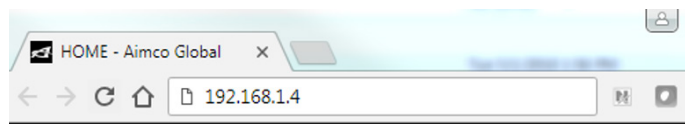

You will see the controller software on your computer screen.



Connecting using the Ethernet Port Directly or via LAN to PC

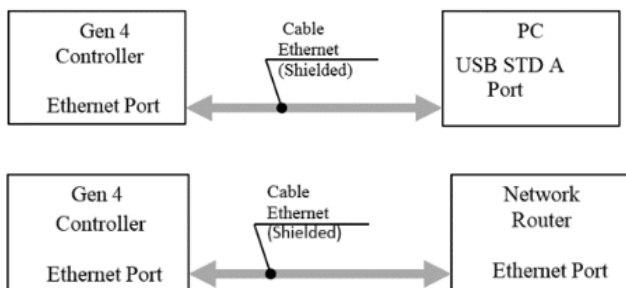

Turn on the computer and make a physical connection by using a straight through Ethernet cable.

Turn on controller. Verify the controller IP address in 'Communication Interfaces' or press toggle button to verify the IP address. If defaulted 0.0.0.0 set desired IP address.

Set a static IP address of the Computer/Laptop to 10.10.30.98 (example) and subnet mask to 255.255.255.0. (For instructions, see the example in "Step 9" earlier in this section.)

To connect to the controller. In the Computer/Laptop open a browser such as Chrome or Firefox. Enter 10.10.30.99, the default Ethernet port IP address.

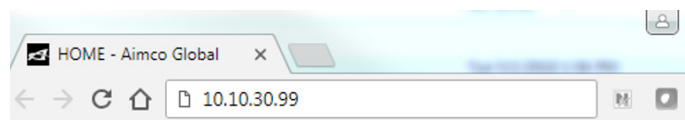

You will see on your computer screen the controller software



NOTE: Controller does not have a DHCP client, it will not automatically configure itself with a usable IP address. Consult your Network Administrator for configuring a correct IP address for your network. The PC, Laptop or Tablet IP address will need to be configured to communicate with the controller.

3.2 Pairing iBC-Z Controller to Uryu UBX-AF Tool

In order to wirelessly connect an Uryu UBX-AFxxxZ series Tool to an iBC4xxxZ controller, the controller's internal Uryu UZig01 Coordinator must be paired with the tool

3.2.1 Requirements

- iBC4xxZ Controller running SYSREL Version 1R22 or greater
- Uryu UBX-AFxxxZ series Tool

3.2.2 Pairing Procedure

1. Remove the battery from the tool.
2. Open the 'ID' cover and remove the PAN ID Sticker.

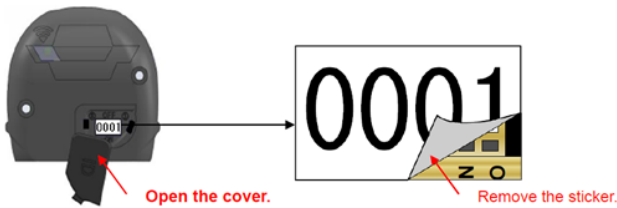

3. Set the tool's DIP switch 8 to ON for PAN ID SETTING PROGRAM MODE.

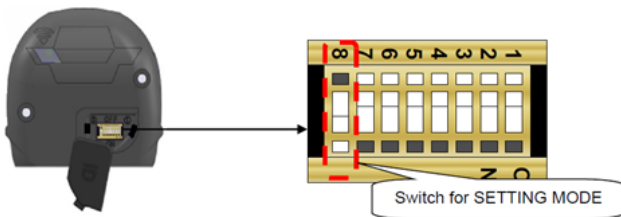

4. Set the tool's remaining DIP Switches as shown in Step 6 and described in the controller dialog as shown

5. Turn ON the iBC-Z Controller and Navigate to Home Menu->Controller->Tool Pairing.

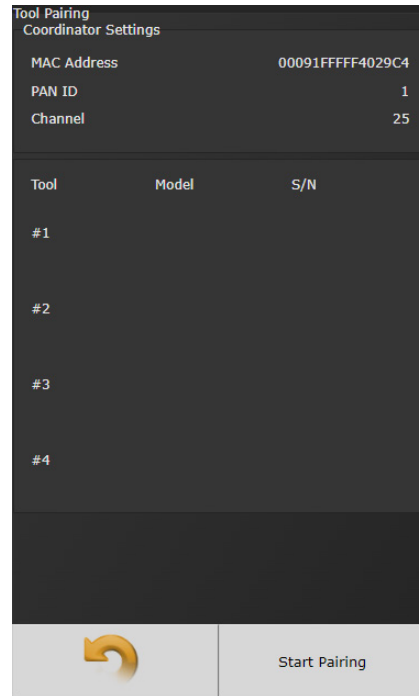

The tool pairing functions allows you to pair up to four tools simultaneously. Only one tool is required to be operational.

6. To begin, select "Start Pairing" to open the switch/PAN settings dialog.

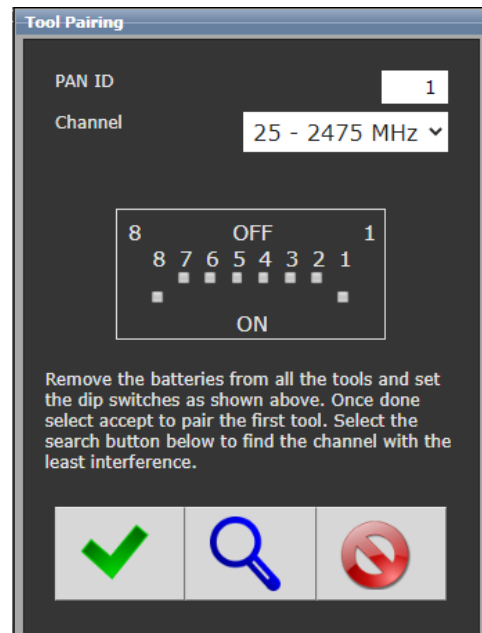

7. Set the 'New Settings' PAN ID to match the tool's Switch Settings.
 - **Pan ID:** This facilitates unique pairing of the tool to the controller's internal Zigbee coordinator

- **Channel:** The Zigbee frequency used to bi-directionally communicate with the tool. Optimal choice of frequency provides best results. Manual selection may be done, or use the built in channel scanning as described in the following steps.

At any time, press  to cancel and return to the main Tool Pairing screen.

8. Press the Start Scan button to run a channel scan, which will search for the channel with the least interference.

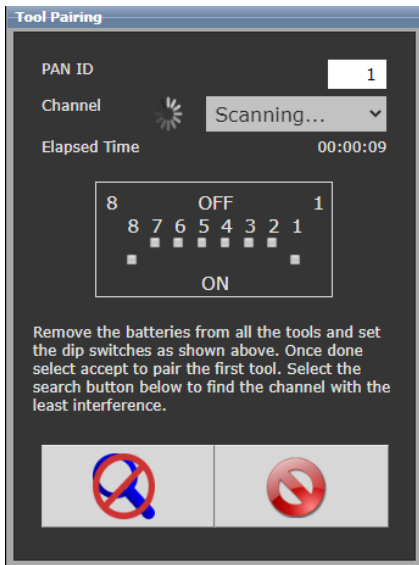

 Scanning will continue until the Scan Stop button is pressed.

When scanning is stopped, the Scan Results window appears, showing a list of all channels and the average noise on each. They are ranked from best to worst.

Zigbee Channel Scan Results		
Channel	Interference Level	Rank
20	40	1
14	43	2
19	44	3
26	45	4
22	47	5
23	48	6
11	51	7
24	51	8
13	59	9
15	60	10
18	62	11
12	65	12
25	66	13
21	75	14
17	82	15
16	89	16

Elapsed Time: 00:00:02



 Press the back arrow button to return to the switch/PAN settings dialog box.

9. The Channel box will automatically be populated with the best channel. The pulldown menu shows other channel options in numerical order, not in ranking order as shown in the Scan Results window.

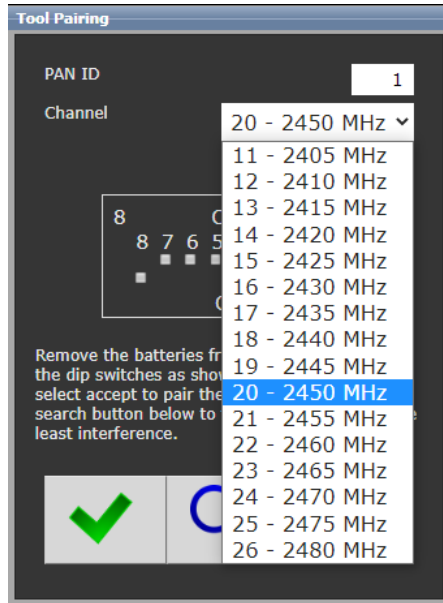

10. Once finished entering data, click  to begin pairing. A configuration screen appears, followed by an instructional screen.

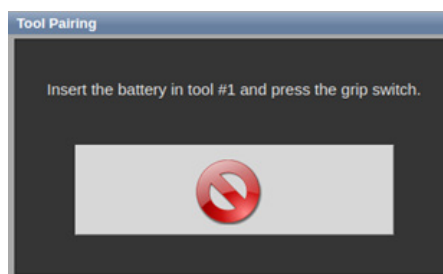
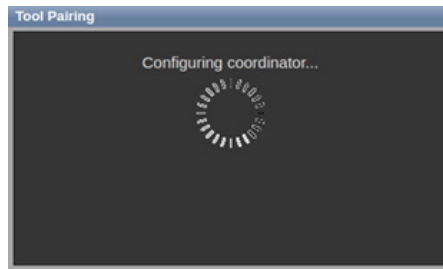

11. Plug in the tool's battery and hold down the Grip Switch on the tool handle to keep the tool ON while the tool is pairing.



12. Verify the tool's ZigBee Communication LED is flashing ON and OFF.



Once these steps have been completed, the tool setup dialog appears.

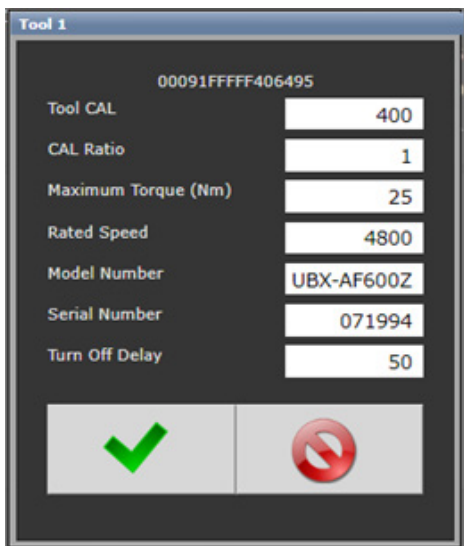

13. Enter tool data

- **Tool CAL** entry should match that which is stamped onto the tool handle
- **CAL Ratio** remains as 1 unless an offset is desired
- **Maximum Torque (NM)** should be entered from Catalog value shown
- **Rated Speed** should be entered from Catalog value shown
- **Model Number** should be entered as correct for the tool
- **Serial Number** should be entered as marked on the tool
- **Turn Off Delay** may be set as desired. Value is a time in which the tool maintains a wireless connection before entering a sleep mode

When all data is entered, press .

14. Another dialog box opens prompting the user to pair another tool.

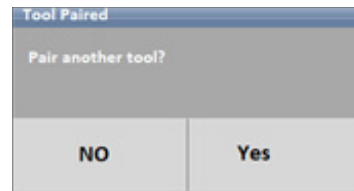

Select "No" if you are finished pairing tools. Select "Yes" to pair another tool, and repeat steps 11 – 13.

15. Once the pairing is complete, the pairing screen will display all paired tools

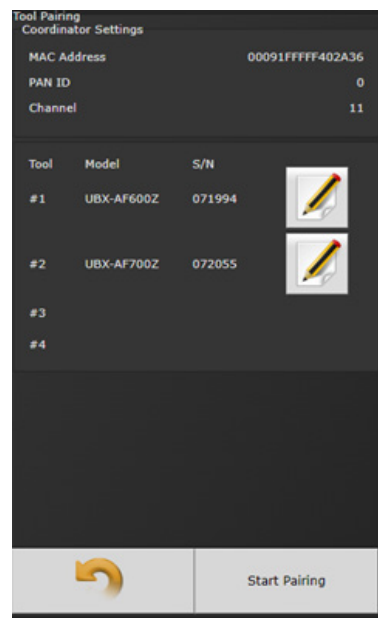

To edit any of the tool parameters, select  to reopen the tool setup dialog.

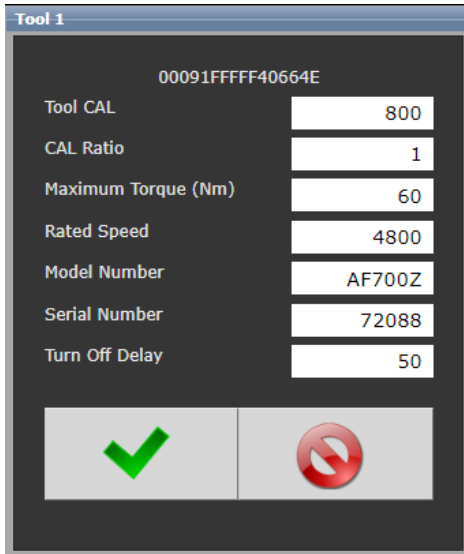

Tool 1	
00091FFFFFF40664E	
Tool CAL	800
CAL Ratio	1
Maximum Torque (Nm)	60
Rated Speed	4800
Model Number	AF700Z
Serial Number	72088
Turn Off Delay	50

Once finished editing, press .

- When the Pairing is complete, a message will appear "Process finished" and the ZigBee Communication LED will turn off.

Process finished. Remove tool battery and set DIP switch OFF to enable.

- When finished pairing all tools, Press  to return to the Controller Configuration Menu.
- Remove the battery from the tool.
- Set the tool's DIP switch 8 to OFF for NORMAL MODE.
- Plug in the tool's battery.
- Verify the tool is now paired and will run.

3.2.3 Problems Pairing

- If after a couple of minutes, the tool pairing process does not complete, double check to make sure the PAN ID switch settings match the New Coordinator Setting and Switch 8 is set to Program Mode and repeat the pairing process.
- Keep the tool's grip switch pressed until the pairing is complete.
- If the value for New Settings – PAN ID is the same as the value for the current Coordinator Settings – Pan ID, and only the Channel is changed, temporarily pair the tool using a different PAN ID, then pair again to the desired PAN ID.

3.2.4 PAN ID Tool Switch Settings

PAN ID Tool Switch Settings									
PAN ID	PAN ID	SW 8	SW 7	SW 6	SW 5	SW 4	SW 3	SW 2	SW 1
Decimal	Hex	Mode	(B6)	(B5)	(B4)	(B3)	(B2)	(B1)	(B0)
0	FE00		OFF	OFF	OFF	OFF	OFF	OFF	OFF
1	FE01		OFF	OFF	OFF	OFF	OFF	OFF	ON
2	FE02		OFF	OFF	OFF	OFF	OFF	ON	OFF
3	FE03		OFF	OFF	OFF	OFF	OFF	ON	ON
4	FE04	ON = Program Mode OFF = Normal Mode	OFF	OFF	OFF	OFF	ON	OFF	OFF
5	FE05		OFF	OFF	OFF	OFF	ON	OFF	ON
6	FE06		OFF	OFF	OFF	OFF	ON	ON	OFF
7	FE07		OFF	OFF	OFF	OFF	ON	ON	ON
8	FE08		OFF	OFF	OFF	ON	OFF	OFF	OFF
9	FE09		OFF	OFF	OFF	ON	OFF	OFF	ON
10	FE0A		OFF	OFF	OFF	ON	OFF	ON	OFF
11	FE0B		OFF	OFF	OFF	ON	OFF	ON	ON
12	FE0C	OFF	OFF	OFF	ON	ON	OFF	OFF	
13	FE0D	OFF	OFF	OFF	ON	ON	OFF	ON	
14	FE0E	OFF	OFF	OFF	ON	ON	ON	OFF	
15	FE0F	OFF	OFF	OFF	ON	ON	ON	ON	
16	FE10	OFF	OFF	ON	OFF	OFF	OFF	OFF	
17	FE11	OFF	OFF	ON	OFF	OFF	OFF	ON	
18	FE12	OFF	OFF	ON	OFF	OFF	ON	OFF	
19	FE13	OFF	OFF	ON	OFF	OFF	ON	ON	
20	FE14	OFF	OFF	ON	OFF	ON	OFF	OFF	
21	FE15	OFF	OFF	ON	OFF	ON	OFF	ON	
22	FE16	OFF	OFF	ON	OFF	ON	ON	OFF	
23	FE17	OFF	OFF	ON	OFF	ON	ON	ON	
24	FE18	OFF	OFF	ON	ON	OFF	OFF	OFF	
25	FE19	OFF	OFF	ON	ON	OFF	OFF	ON	
26	FE1A	ON = Program Mode OFF = Normal Mode	OFF	OFF	ON	ON	OFF	ON	OFF
27	FE1B		OFF	OFF	ON	ON	OFF	ON	ON
28	FE1C		OFF	OFF	ON	ON	ON	OFF	OFF
29	FE1D		OFF	OFF	ON	ON	ON	OFF	ON
30	FE1E		OFF	OFF	ON	ON	ON	ON	OFF
31	FE1F		OFF	OFF	ON	ON	ON	ON	ON
32	FE20		OFF	ON	OFF	OFF	OFF	OFF	OFF
33	FE21		OFF	ON	OFF	OFF	OFF	OFF	ON
34	FE22	OFF	ON	OFF	OFF	OFF	ON	OFF	
35	FE23	OFF	ON	OFF	OFF	OFF	ON	ON	
36	FE24	OFF	ON	OFF	OFF	ON	OFF	OFF	
37	FE25	OFF	ON	OFF	OFF	ON	OFF	ON	
38	FE26	OFF	ON	OFF	OFF	ON	ON	OFF	
39	FE27	OFF	ON	OFF	OFF	ON	ON	ON	
40	FE28	OFF	ON	OFF	ON	OFF	OFF	OFF	
41	FE29	OFF	ON	OFF	ON	OFF	OFF	ON	
42	FE2A	OFF	ON	OFF	ON	OFF	ON	OFF	
43	FE2B	OFF	ON	OFF	ON	OFF	ON	ON	
44	FE2C	OFF	ON	OFF	ON	ON	OFF	OFF	
45	FE2D	OFF	ON	OFF	ON	ON	OFF	ON	
46	FE2E	OFF	ON	OFF	ON	ON	ON	OFF	
47	FE2F	OFF	ON	OFF	ON	ON	ON	ON	
48	FE30	OFF	ON	ON	OFF	OFF	OFF	OFF	
49	FE31	OFF	ON	ON	OFF	OFF	OFF	ON	
50	FE32	ON = Program Mode OFF = Normal Mode	OFF	ON	ON	OFF	OFF	ON	OFF
51	FE33		OFF	ON	ON	OFF	OFF	ON	ON
52	FE34		OFF	ON	ON	OFF	ON	OFF	OFF
53	FE35		OFF	ON	ON	OFF	ON	OFF	ON
54	FE36		OFF	ON	ON	OFF	ON	ON	OFF
55	FE37		OFF	ON	ON	OFF	ON	ON	ON
56	FE38		OFF	ON	ON	ON	OFF	OFF	OFF
57	FE39		OFF	ON	ON	ON	OFF	OFF	ON
58	FE3A	OFF	ON	ON	ON	OFF	ON	OFF	
59	FE3B	OFF	ON	ON	ON	OFF	ON	ON	
60	FE3C	OFF	ON	ON	ON	ON	OFF	OFF	
61	FE3D	OFF	ON	ON	ON	ON	OFF	ON	
62	FE3E	OFF	ON	ON	ON	ON	ON	OFF	
63	FE3F	OFF	ON	ON	ON	ON	ON	ON	

PAN ID Tool Switch Settings									
PAN ID	PAN ID	SW 8	SW 7	SW 6	SW 5	SW 4	SW 3	SW 2	SW 1
Decimal	Hex	Mode	(B6)	(B5)	(B4)	(B3)	(B2)	(B1)	(B0)
64	FE40		ON	OFF	OFF	OFF	OFF	OFF	OFF
65	FE41		ON	OFF	OFF	OFF	OFF	OFF	ON
66	FE42		ON	OFF	OFF	OFF	OFF	ON	OFF
67	FE43		ON	OFF	OFF	OFF	OFF	ON	ON
68	FE44		ON	OFF	OFF	OFF	ON	OFF	OFF
69	FE45		ON	OFF	OFF	OFF	ON	OFF	ON
70	FE46		ON	OFF	OFF	OFF	ON	ON	OFF
71	FE47		ON	OFF	OFF	OFF	ON	ON	ON
72	FE48	ON = Program Mode OFF = Normal Mode	ON	OFF	OFF	ON	OFF	OFF	OFF
73	FE49		ON	OFF	OFF	ON	OFF	OFF	ON
74	FE4A		ON	OFF	OFF	ON	OFF	ON	OFF
75	FE4B		ON	OFF	OFF	ON	OFF	ON	ON
76	FE4C		ON	OFF	OFF	ON	ON	OFF	OFF
77	FE4D		ON	OFF	OFF	ON	ON	OFF	ON
78	FE4E		ON	OFF	OFF	ON	ON	ON	OFF
79	FE4F		ON	OFF	OFF	ON	ON	ON	ON
80	FE50		ON	OFF	ON	OFF	OFF	OFF	OFF
81	FE51		ON	OFF	ON	OFF	OFF	OFF	ON
82	FE52		ON	OFF	ON	OFF	OFF	ON	OFF
83	FE53		ON	OFF	ON	OFF	OFF	ON	ON
84	FE54		ON	OFF	ON	OFF	ON	OFF	OFF
85	FE55		ON	OFF	ON	OFF	ON	OFF	ON
86	FE56		ON	OFF	ON	OFF	ON	ON	OFF
87	FE57		ON	OFF	ON	OFF	ON	ON	ON
88	FE58		ON	OFF	ON	ON	OFF	OFF	OFF
89	FE59		ON	OFF	ON	ON	OFF	OFF	ON
90	FE5A		ON	OFF	ON	ON	OFF	ON	OFF
91	FE5B		ON	OFF	ON	ON	OFF	ON	ON
92	FE5C		ON	OFF	ON	ON	ON	OFF	OFF
93	FE5D		ON	OFF	ON	ON	ON	OFF	ON
94	FE5E		ON	OFF	ON	ON	ON	ON	OFF
95	FE5F	ON = Program Mode OFF = Normal Mode	ON	OFF	ON	ON	ON	ON	ON
96	FE60		ON	ON	OFF	OFF	OFF	OFF	OFF
97	FE61		ON	ON	OFF	OFF	OFF	OFF	OFF
98	FE62		ON	ON	OFF	OFF	OFF	ON	OFF
99	FE63		ON	ON	OFF	OFF	OFF	ON	ON
100	FE64		ON	ON	OFF	OFF	ON	OFF	OFF
101	FE65		ON	ON	OFF	OFF	ON	OFF	ON
102	FE66		ON	ON	OFF	OFF	ON	ON	OFF
103	FE67	ON	ON	OFF	OFF	ON	ON	ON	
104	FE68		ON	ON	OFF	ON	OFF	OFF	OFF
105	FE69		ON	ON	OFF	ON	OFF	OFF	ON
106	FE6A		ON	ON	OFF	ON	OFF	ON	OFF
107	FE6B		ON	ON	OFF	ON	OFF	ON	ON
108	FE6C		ON	ON	OFF	ON	ON	OFF	OFF
109	FE6D		ON	ON	OFF	ON	ON	OFF	ON
110	FE6E		ON	ON	OFF	ON	ON	ON	OFF
111	FE6F		ON	ON	OFF	ON	ON	ON	ON
112	FE70		ON	ON	ON	OFF	OFF	OFF	OFF
113	FE71		ON	ON	ON	OFF	OFF	OFF	ON
114	FE72		ON	ON	ON	OFF	OFF	ON	OFF
115	FE73		ON	ON	ON	OFF	OFF	ON	ON
116	FE74		ON	ON	ON	OFF	ON	OFF	OFF
117	FE75		ON	ON	ON	OFF	ON	OFF	ON
118	FE76		ON	ON	ON	OFF	ON	ON	OFF
119	FE77		ON	ON	ON	OFF	ON	ON	ON
120	FE78		ON	ON	ON	ON	OFF	OFF	OFF
121	FE79		ON	ON	ON	ON	OFF	OFF	ON
122	FE7A		ON	ON	ON	ON	OFF	ON	OFF
123	FE7B		ON	ON	ON	ON	OFF	ON	ON
124	FE7C		ON	ON	ON	ON	ON	OFF	OFF
125	FE7D		ON	ON	ON	ON	ON	OFF	ON
126	FE7E		ON	ON	ON	ON	ON	ON	OFF
127	FE7F		ON	ON	ON	ON	ON	ON	ON

4. Home Page (Main Menu)

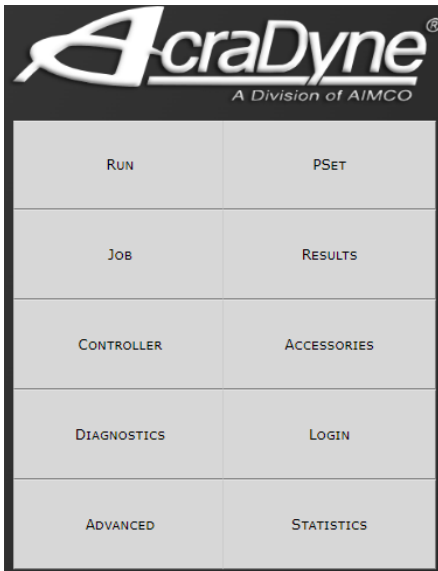

4.1 Run

The Run Screen is essentially the dashboard of the Gen IV controller and provides a look at real-time information regarding rundowns.

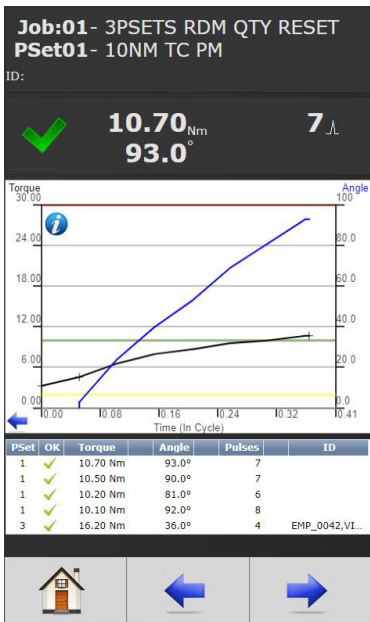

Time (In-Cycle) Screen

JOB:	Indicates the current JOB.
PSet:01	Indicates the current PSet in which you are operating.
	Indicates accepted rundown.
	Indicates failed rundown.
11.90Nm 210°	Displays Torque and Angle for current rundown.
7	Number of Pulses.

Graph displays curves representing Torque (black trace) and Angle (blue trace). The blue left arrow at the origin of the graph will change the X-axis of the rundown curve from Time (In-Cycle) to Time (Overall) and Angle.

Below the graph is a historical table that will give information and status of the most recent rundowns, including current PSet, accepted/failed rundown status, torque and angle.



Arrows allow user to scroll through screens that show real time Job information such as Run Screen or rundown indicators.

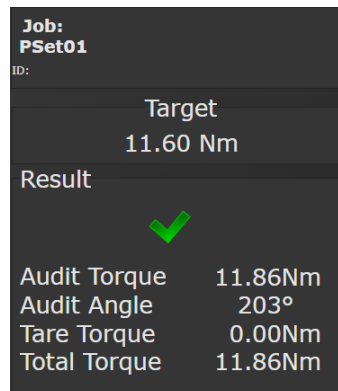

Home tab will return user to the Home Page

On the Run Screen, click for curve detail.

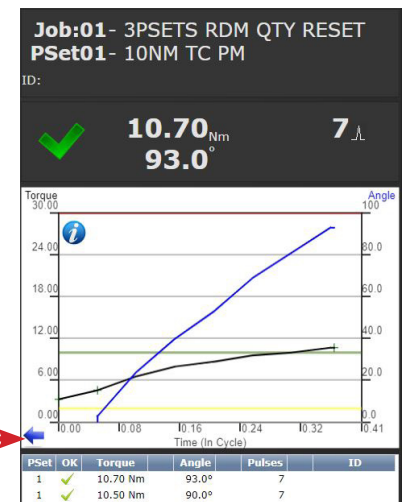

Click on blue arrow to change curve X axis.

Choose Time In-cycle, Time Overall, Angle, or Angle In-Cycle screen

Large Screen Indicators and Audit information

The large screen indicators are helpful in viewing real time results of the rundown from a distance.

Example of Accepted Job

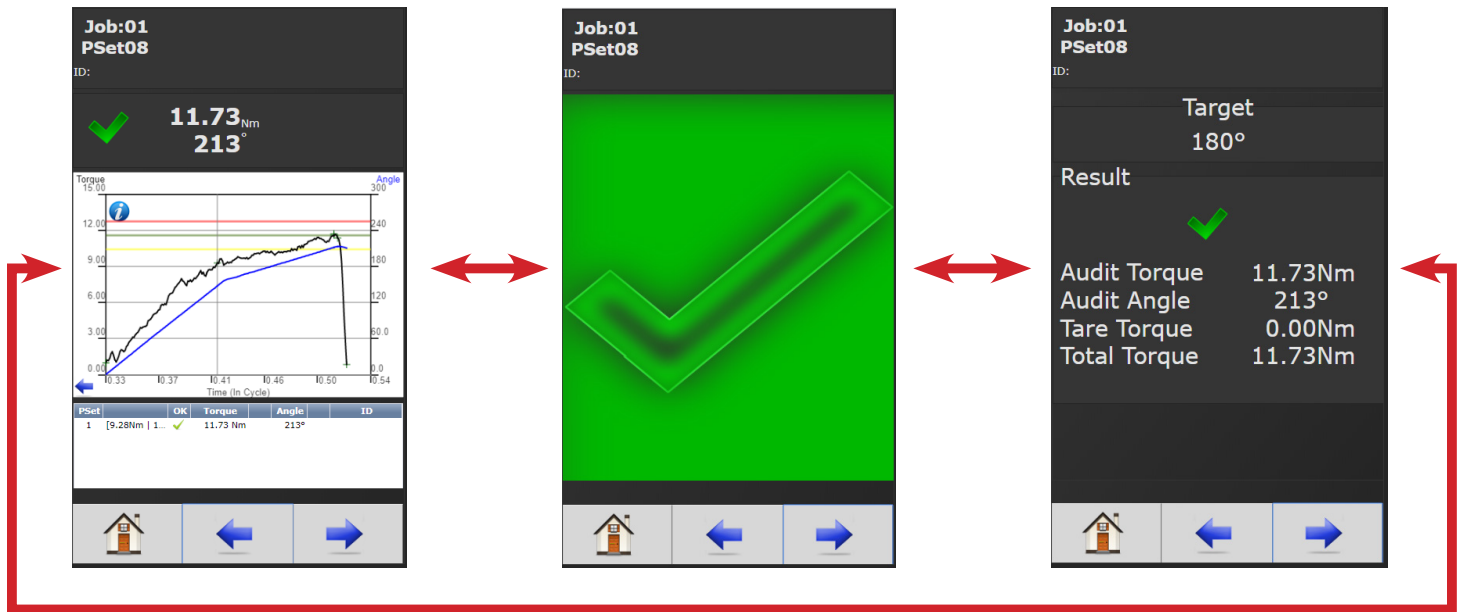

Example of Failed Job

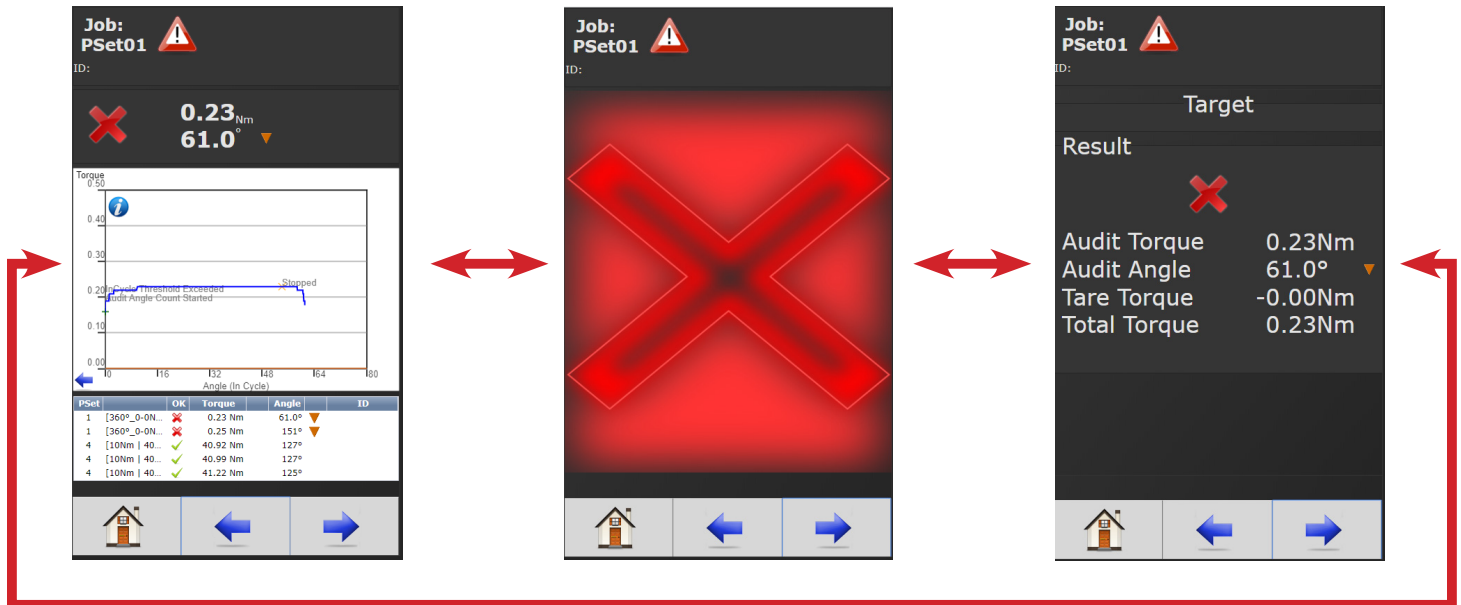

4.2 PSet

Parameter Settings (PSets) control the fastening process. The following describes the different fastening strategies and how to setup the basic PSet parameters necessary to perform a fastening. Up to 256 PSets are available.

4.2.1 Add New PSet

On Home Page press the  tab.

On PSets screen press  to add a new PSet.

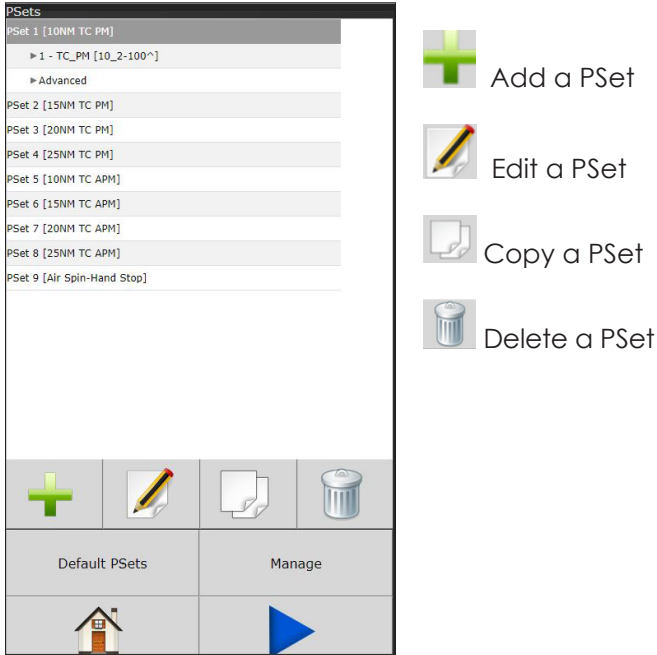

Default PSets: See "4.2.5 Default PSets" on page 19.
Manage: See "4.2.6 Manage PSets" on page 19.

On Add New PSet screen (below) enter appropriate values.

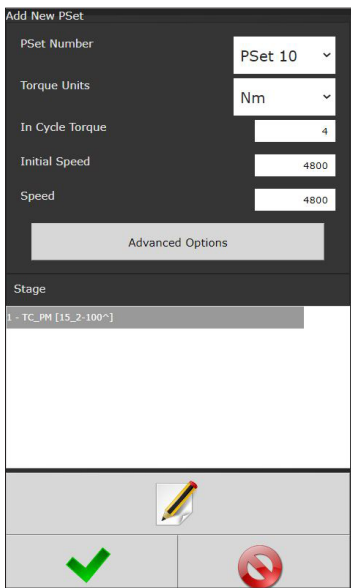

PSet Number: Current PSet to be added.

Torque Units: Unit of measure.

In Cycle Torque: Threshold value at which tool is "In Cycle" and results from the Rundown will be reported.

Initial Speed: Tool output free speed before the fastening torque reaches In Cycle Torque (RPM)

Speed: Tool output downshift speed after the fastening torque exceeds In Cycle Torque (RPM)

Advanced Options: (see "4.2.4 Advanced Options" on page 18)

Once PSet values are entered press  to enter stage information for the PSet.

4.2.1.1 Add New Stage

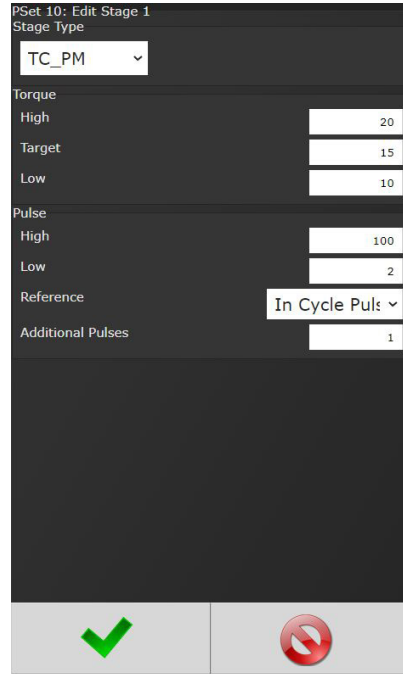

One stage can be assigned per PSet.

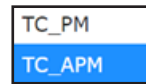

The following stage options are available (for stage descriptions, see "4.2.2 PSet Stages" on page 16):



Once the desired stage(s) are selected and configured, press  to save stage and again to save the **PSet** and return to initial PSet menu.

Next Press  to go to the **RUN** screen or  to return to the **Home** page. The tool should now be operational and you are ready to run a configured PSet.

4.2.2 PSet Stages

4.2.2.1 TC_PM Torque Control Pulse Monitor

PSet 10: Edit Stage 1
Stage Type

TC_PM ▾

Torque

High

Target

Low



Pulse

High

Low

Reference

Additional Pulses

Torque High: Upper control limit of the rundown.

Torque Target: Final desired torque (CUT Level).

Torque Low: The lower control limit of the rundown.

Pulse High: Maximum acceptable pulses

Pulse Low: Minimum acceptable pulses

Pulse Reference: (drop down menu)

- **In-cycle Pulse:** Monitoring number of tool Pulse begins after the tool overcomes pre-set in-cycle Torque
- **Stage Pulse:** Monitoring all Pulses specifically in the Stage

Additional Pulses: After reaching target torque, additional pulses to be applied before shutting off the tool.

4.2.2.2 TC_APM Torque Control Angle Pulse Monitor

PSet 10: Edit Stage 1
Stage Type

TC_APM ▾

Torque

High

Target

Low

Angle

High

Low

Reference

Reference Torque

Pulse

High

Low

Reference

Additional Pulses

✓
⊘

In addition to the settings for TC_PM, the TC_APM adds the angle monitor settings.

Torque High: Upper control limit of the rundown.

Torque Target: Final desired torque (CUT Level).

Torque Low: The lower control limit of the rundown.

Angle High: Maximum acceptable angle rotation in degrees.

Angle Low: Minimum acceptable angle rotation in degrees.

Angle Reference (drop down menu):

- **In-cycle Angle:** Angle is measured from In-Cycle torque value (determined in PSet screen).
- **Stage Angle:** Angle is measured from Reference Torque. If Stage Angle is selected, this will be the start point (in Torque) at which angle is monitored.

Angle Reference Torque: If Stage Angle is selected in the Reference menu, this will be the Torque start point at which angle is monitored.

Pulse High: Maximum acceptable pulses

Pulse Low: Minimum acceptable pulses

Pulse Reference: (drop down menu)

- **In-cycle Pulse:** Monitoring number of tool Pulse begins after the tool overcomes pre-set in-cycle Torque
- **Stage Pulse:** Monitoring all Pulses specifically in the Stage

Additional Pulses: After reaching target torque, additional pulses to be applied before shutting off the tool.

4.2.3 Edit PSet

On Home page press 

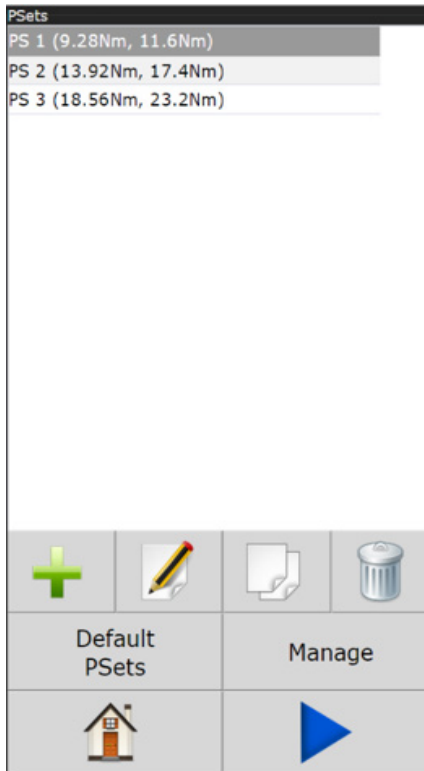

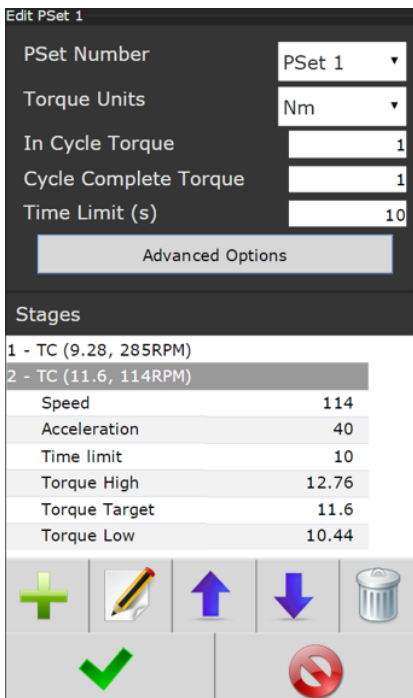

On the PSet screen click on the desired PSet you would like to edit.

Click on the Edit button  to make changes in the Edit screen (below).

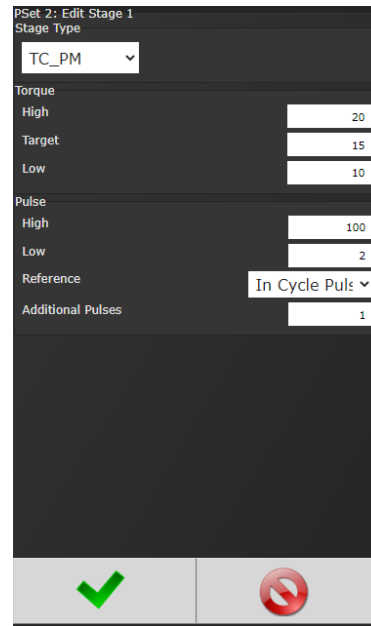

If further Stage changes are needed click the Edit button  again to enter Edit Stage screen.



Once desired changes are made click  twice to save changes.

4.2.4 Advanced Options

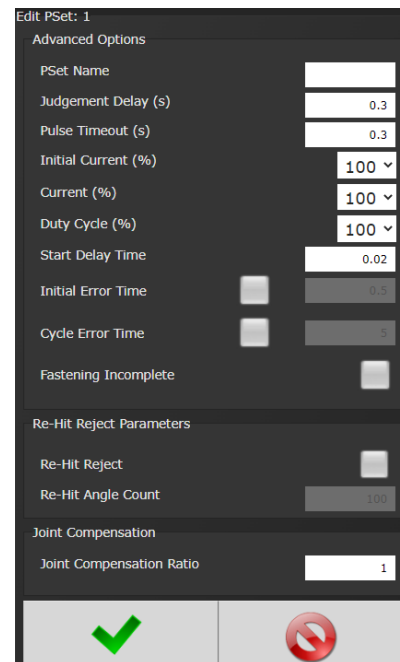

PSet Name: Add PSet name if desired (up to 20 characters).

Judgment Delay (s): Tool provides judgment after tool stops producing pulses and this delay expires.

Pulse Timeout (s): what does this do?

Initial Current (%): Percentage of maximum current delivered to the motor before in-cycle torque threshold. Reduce

this value to reduce the amplitude of torque pulses.

Current (%): Percentage of maximum current delivered to the motor after in-cycle torque threshold is exceeded.

Duty Cycle (%): Default 100%

Start Delay Time: The primary use of this timer is to ignore seating torque or early stray pulses from contributing to the rundown results. This timer starts when the torque reaches In-Cycle. During this delay time, torque is not compared to the target. When the time is up, the peak torque is reset. This can be useful if there is an initial spike in the torque when the tool first starts or at the fasteners first seating point.

Initial Error Time: If enabled, and the torque reaches the target before the Initial Error timer times out, the overall result of the rundown will be NOK, regardless if the final torque, pulse, and angle are within limits. This time starts when the tool starts.

Cycle Error Time: If enabled, and the torque reaches the target before the Cycle Error timer times out, the overall result of the rundown will be NOK, regardless of if the final torque, pulse, and angle are within limits. This time starts when the torque exceeds In Cycle Torque

Fastening Incomplete: If enabled, and the operator lets go of the trigger before the fastening is complete, the overall result of the rundown will be NOK, regardless if the final torque, pulse, and angle are within limits.

Re-Hit Reject: If enabled, the tool will stop and the rundown will be aborted, if the angle of rotation from 0.4 seconds before the in-cycle pulse to the in-cycle pulse is less than the Re-Hit Angle Count.

Re-Hit Angle Count: The is the minimum angle of rotation from 0.4 seconds before the in-cycle pulse to the in-cycle pulse. If the angle change during this time is less than the Re-Hit Angle Count, it is determined to be a Re-Hit.

Joint Compensation Ratio: Adjusts the target torque of the tool to compensate for joint characteristics. This value has an inverse relationship with the target torque ($\text{Output torque} = \text{Target Torque} / \text{Ratio}$). Ratio values above 1.0 result in a lower output torque where values below 1.0 result in higher output torques.

4.2.5 Default PSets

This will generate three generic PSets for the tool connected to the controller. It will automatically use the 40%, 60%, and 80% of the rated maximum torque of the tool in a two-stage Torque Control Pulse Monitor Strategy (TC_PM). A prompt will display rated

Max Torque and Max RPM of the connected tool for reference. These Psets can be modified to meet application requirements.

4.2.6 Manage PSets

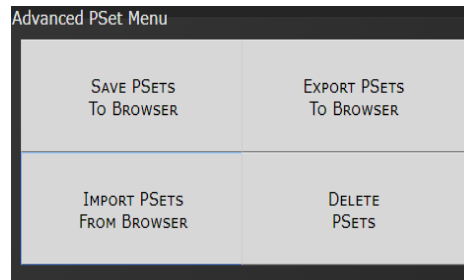

Save PSets to Browser

Allows the PSet information to be saved to the local PC connected to controller. PSet information is saved as a .txt file and can be opened using any text editor such as WordPad. It can also be opened with Excel. The format of the .txt file is tab separated values.

Export PSets to Browser

Save the PSets as a database file to the PC connected to controller. These PSets can later be imported to another controller.

Import PSets from Browser

Import previously exported PSets to controller.

Delete PSets

Enables deletion of selected PSets.

4.3 Job

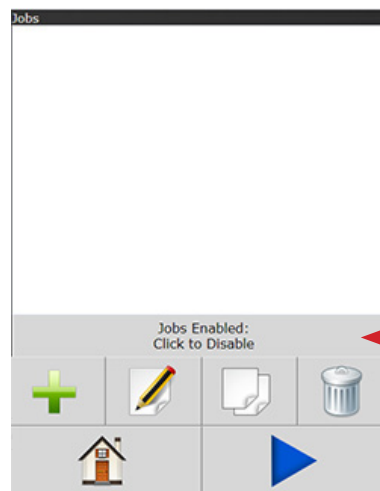

A Job is a collection of PSets which can be run when performing multiple fastening operations on a single application.



Jobs provide:

- Error proofing
- Logical grouping of PSets
- Fastening order
- Job status

Click to Enable/Disable Job function.

To add a new Job press  on the Home Page. Press  on Jobs screen (above) to enter Add New Job screen (below)

Job Number: Up to 99 Jobs can be configured.

Job Name: Enter Job Name

Job Action:

- **Disable Tool:** Disable tool after job is finished. Job complete Icon will appear.





Tool will not operate until job is reset.

- **Reset Job:** Will reset after Job is finished. Once Reset Job is finished, the following icon appears:

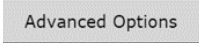

This means that results from the last successful rundown of a job are cleared. Information from last successful rundown can still be accessed in the Results screen (see "4.4 Results" on page 21).

Enter Advanced Options  if needed (see next section).

After appropriate values are entered, press  to go to Add New Job Sequence screen.

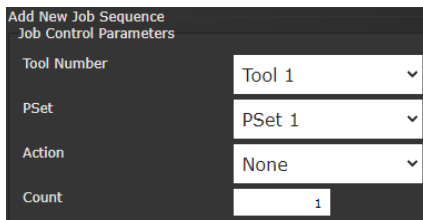

Tool Number: When more than one tool is paired, select the appropriate tool for the job.

PSet Number: Choose any current PSet already configured in controller.

Action:

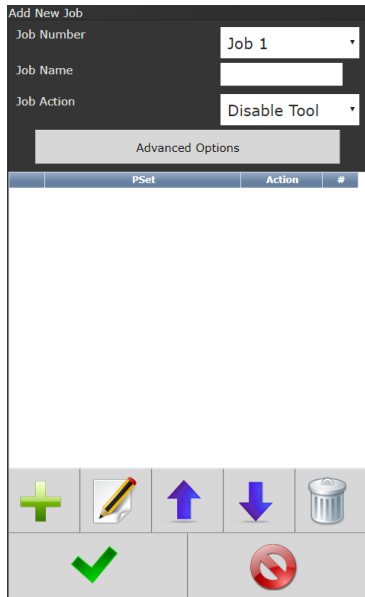

- **None:** Will stay in current sequence.
- **Next:** will advance to next sequence set up after count is reached.

Count: Fastener number required to complete sequence.

Once values are entered press  two times to return to Job screen

4.3.2 Advanced Options

Enter Advanced Options  if needed

Lock on Reject Parameters:

- **Enable:** When enabled, this prevents tool from starting a new rundown if the result of the last rundown was a reject. Tool remains locked until one of the four Unlock Mode conditions are satisfied.

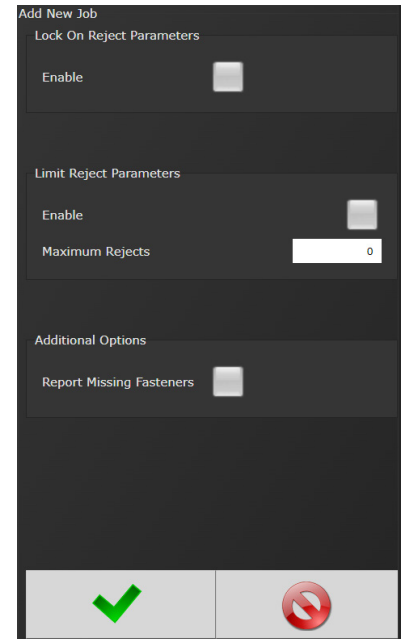

Limit Reject Parameters:

- **Enable:** Enable or Disable
- **Maximum Rejects:** Number of rejected fasteners allowed

Additional Options:

- **Report Missing Fasteners:** Add an option to each JOB to allow the reporting of any missing fasteners. When it is set the controller will report an NOK rundown for each fastener that is defined in the JOB but has not been ran. These NOK results will be reported whenever a new job is started AND the prior JOB is incomplete.

These generated NOK results are treated like any other fastening. They are displayed on the run screen, stored in the results and transmitted on all protocols.

4.3.3 Jobs "Enabled" Display and Button Function



- Increment and Decrement buttons change the job sequence. The PSet number will change and job sequence number on secondary display will change if jobs are enabled.
- Holding the toggle button will display will display the Job number, while pressing increment or decrement buttons will change it. The two numbers on the PSet/Job display will be separated by decimals.
- Pressing the toggle button will change secondary display between:
 - Units of measure
 - Ethernet 1 IP address
 - Ethernet 2 IP address
 - System port IP address
 - Angle report
 - Bolt count
 - Job sequence

NOTE: Job sequence shows which PSet you are currently on in the job (this is not the pset number). The first pset in the job is always job sequence 1, and the next is 2, etc.

Bolt count is shown as current bolt count out of total number of bolts. Example: If you have 3 total bolts. When you start the job you will see 0.3. After one rundown you will see 1.3 and then 2.3 on the next run and so on until the job is completed.

ID	Time Stamp	PS...	OK	Torque	Angle
585	01-07 19:13:02	2	✓	17.46 Nm	341
584	01-07 19:12:59	2	✓	17.77 Nm	351
583	01-07 19:12:57	2	✓	17.93 Nm	372
582	01-07 19:12:52	2	✓	18.09 Nm	350
581	01-07 19:12:50	2	✓	17.61 Nm	338
580	01-07 19:12:48	2	✓	18.03 Nm	359
579	01-07 19:12:46	2	✓	17.46 Nm	354
578	01-07 19:12:43	2	✓	18.13 Nm	377
577	01-07 19:12:41	2	✓	17.59 Nm	359
576	01-07 19:12:36	2	✓	17.76 Nm	377
575	01-07 19:12:33	2	✓	17.76 Nm	359
574	01-07 19:12:29	2	✓	17.70 Nm	377
573	01-07 19:12:27	2	✓	17.58 Nm	358
572	01-07 19:12:22	2	✓	17.97 Nm	384

This screen provides a history of rundowns performed. Information such as ID Number, Time Stamp, Parameter Set#, Accept / Reject status, and Torque and Angle are recorded for each rundown.

	Filter Button gives filter options in Rundown screen.
	Save Button saves rundowns as .Txt File.
	Deletes individual rundowns by clicking on them
	Select Columns Button lets you customize the columns shown on the Results Screen
	Home Button returns to main display menu.
	Play Button sends you directly to Run Screen.
	Refresh Button refreshes screen to include latest rundowns.

4.4 Results

1106 Results

Time Stamp	PSet	OK	Torque	Angle	Pulses
09/29 14:21:33	1	✓	10.60 Nm	33.0°	3
09/29 14:21:23	1	✓	10.30 Nm	33.0°	3
09/29 14:21:20	1	✗	11.20 Nm	0.0°	1

Click on Individual Runs for Rundown information.

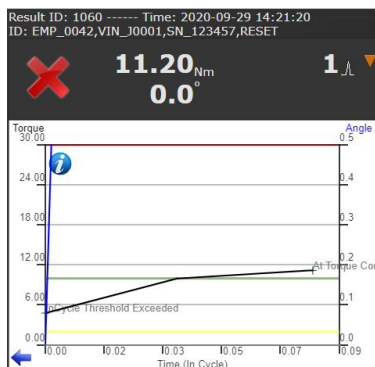

Example: Rejected Rundown Information.

4.4.1 Saving Rundown(s)

Saving All Rundowns

Click on  in main rundown screen to view/save total rundowns. A dialog box will open that allows you to choose the download format, either a CSV file or a TW4 file. The CSV file includes rundown data in tab separated variables and can be viewed using Excel or opened in text editor such as Notepad. The raw data can be imported to Excel to build graphs, charts etc. Contact AIMCO Technical Service for pre-made Torque and Angle Templates.

The TW4 file can be opened using the ACE Platform G4 Utility located on the [software page](#) of the AIMCO website.

Save Results

File Type:

Include Stage Results:

Include Log Entries:

The dialog box also shows options for including stage results or log entries in the downloaded file. If downloading a TW4 file, all information will be automatically selected.

Click  and your browser will download the file.

Saving Individual Rundowns

ID	Time Stamp	PS...	OK	Torque	Angle
490	01-01 01:01:28	1	✓	15.69 Nm	3
489	01-01 01:01:27	1	✓	15.33 Nm	3

To save an individual rundown, select a

rundown from the Results screen.

This opens the Rundown Information View. Click on  in save the rundown. The file will automatically download as a CSV file.

Rundown Information View

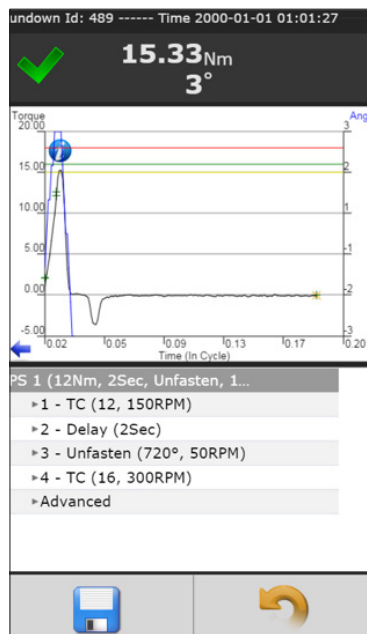

Sample of Individual Rundown Information

1	Result	65	
2	Job Numb	1	
3	Job Name	Paramont	
4	Job Seque	1	
5	Bolt Coun	3	
6	Date	##### 4:18:00	
7	Master Ru	0	
8	PSet ID	59	
9	PSet Num	1	
10	PSet Name		
11	Tool Mod	AEN32030A	
12	Tool Seria	191111	
13	Torque	11.69	
14	Angle	57	
15	Pulses	0	
16	Torque St: P		
17	Angle Stat--		
18	Pulse Stat --		
19	Rundown P		
20	Tool Cycle	1111	
21	ID1 ("ID #1)	2.2E+10	
22	ID2 ("ID #2)	4.86E+10	
23	ID3 ("ID #3")		
24	ID4 ("ID #4")		
25			
26			
27			
28	Curves		
29	Tick	Torque	Angle
30	0	0.02	0
31	1	0.02	0
32	2	0.05	0
33	3	0.04	0
34	4	0.09	0

4.5 Controller

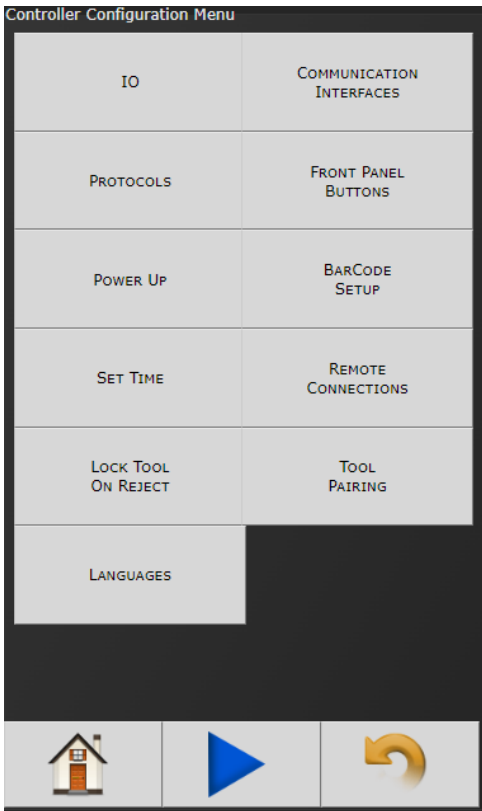

The controller menu is where all of the settings for the Gen IV controller are configured. All of the different configuration capabilities are explained in the following sections.

4.5.1 IO

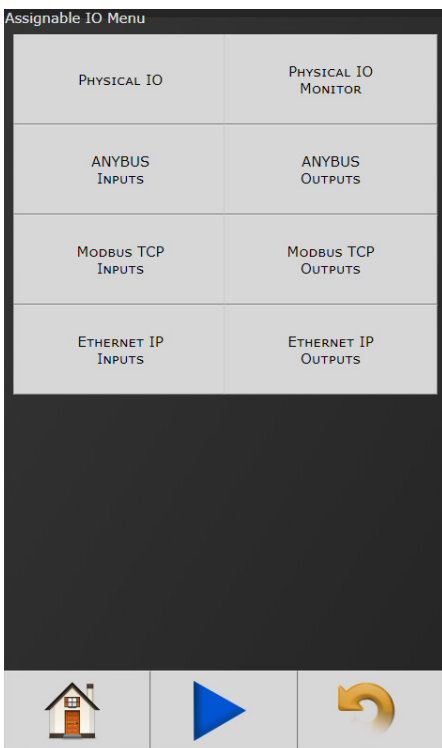

NOTE: See "11. Assignable I/O" on page 49 for details.

4.5.1.1 Physical I/O

Physical I/O Configuration			
Input	Function	State	Force
---1---	Start	<input checked="" type="checkbox"/>	<input type="checkbox"/>
---2---	Reverse	<input checked="" type="checkbox"/>	<input type="checkbox"/>
---3---	Stop	<input checked="" type="checkbox"/>	<input type="checkbox"/>
---4---	Select PSet / [...]	<input checked="" type="checkbox"/>	<input type="checkbox"/>
---5---	Used By Input...	<input checked="" type="checkbox"/>	<input type="checkbox"/>
---6---	Used By Input...	<input checked="" type="checkbox"/>	<input type="checkbox"/>
---7---	Reset Job	<input checked="" type="checkbox"/>	<input type="checkbox"/>
---8---	Remove Lock ...	<input checked="" type="checkbox"/>	<input type="checkbox"/>

Output	Function	State	Force
---1---	OK	<input checked="" type="checkbox"/>	<input type="checkbox"/>
---2---	NOK	<input checked="" type="checkbox"/>	<input type="checkbox"/>
---3---	In Cycle	<input checked="" type="checkbox"/>	<input type="checkbox"/>
---4---	Torque High	<input checked="" type="checkbox"/>	<input type="checkbox"/>
---5---	Torque Low	<input checked="" type="checkbox"/>	<input type="checkbox"/>
---6---	Angle High	<input checked="" type="checkbox"/>	<input type="checkbox"/>
---7---	Angle Low	<input checked="" type="checkbox"/>	<input type="checkbox"/>
---8---	Job Complete	<input checked="" type="checkbox"/>	<input type="checkbox"/>

Assign functionality to 24V Input and Output pins. Shows the "live state" of each Input and Output.

Functions shown in screen shot are default settings.

To change these assignments, click on any I/O state to enter Output/Input Configuration screen (following).

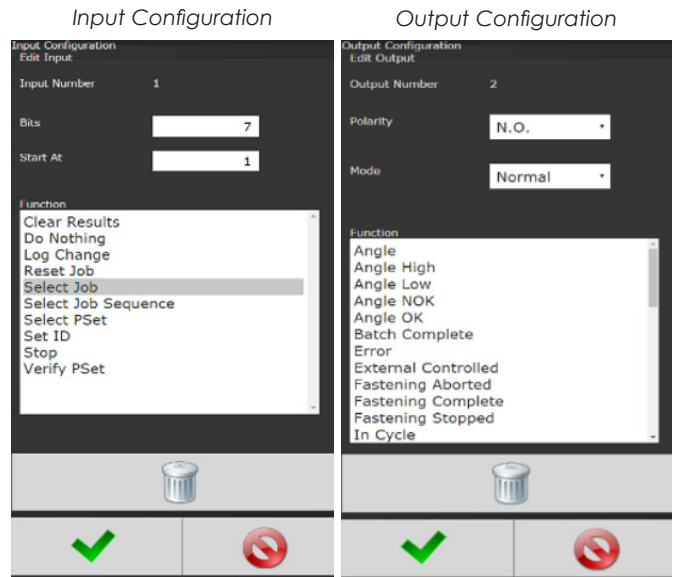

See "11. Assignable I/O" on page 49 for more details on available assignment functions and how to configure.

See "10. 24 Volt I/O" on page 47 for the pinout of the 24Volt Logic IO port, and wiring examples.

4.5.1.2 Physical I/O Monitor

Provides monitoring of Physical 24 Volt I/O. Force on/off the individual I/O pins for testing of field wiring.

Each indicator shows the state of the associated pin.

Green = On
Red = Off

- **Force:** When Buttons from I/O are selected, this field selects which Inputs and Outputs can be forced through the Monitor I/O screen.

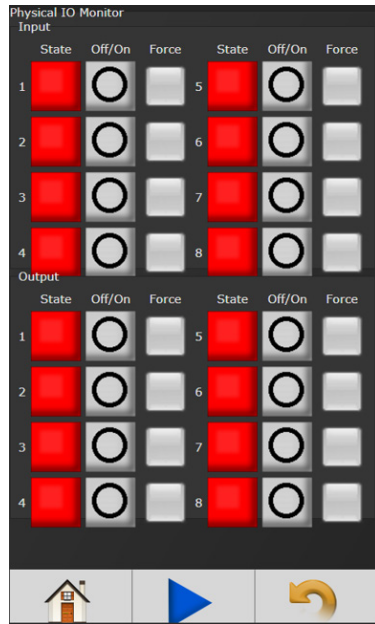

- **Off/On:** If Force is enabled this button will toggle the state of input or output selected.

NOTE: See "11. Assignable I/O" on page 49 for details.

4.5.1.3 Anybus/Modbus TCP/Ethernet IP Inputs

These types of communication are useful for data communication between controller and PLCs. It is an effective, quick way for the data transfer of short data packages.

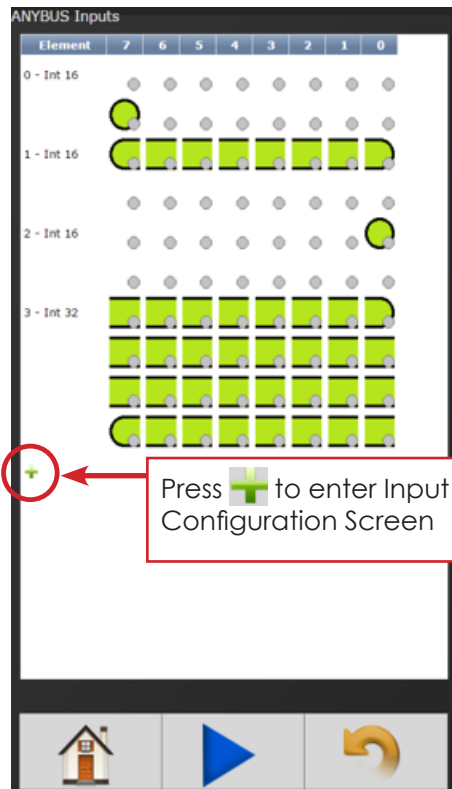

Press to enter Input Configuration Screen

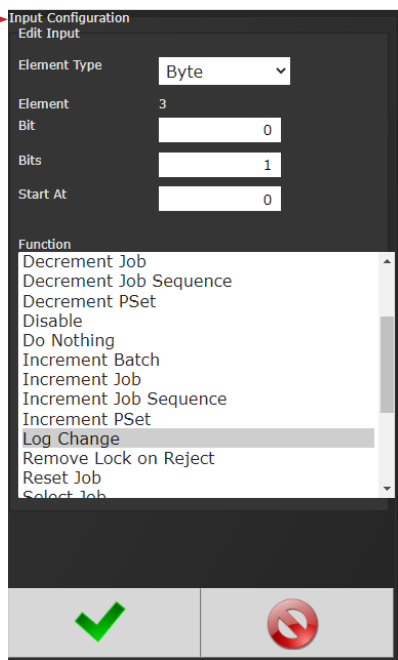

Element Type: Choose from Byte, Int16, Int32, or ASCII.

Element: Shows element # being configured

Bit: Enter Bit #.

Bits: # of bits the assignment will read.

Start at: Starting bit location.

Polarity (not shown): Select Normally Open (N.O.) or Normally Closed Outputs (N.C.).

Length (not shown, available in ASCII ID function): Number of characters desired to send.

Torque (not shown, available in Click Wrench function): Torque value to be reported when using Click Wrench input. Value input is what will be sent from controller when Input Signal is received from a Click Wrench. **Value is NOT calculated by the controller rather it is solely what the Click Wrench is calibrated to by outside means.**

Torque Units (not shown, available with Click Wrench function): Choose from Nm, Kgm, Kgcm, Ftlb, and Inlb.

Function: See "11. Assignable I/O" on page 49 for details. Select desired Input Function(s).

Click on after appropriate selections are made.

Example of the Anybus Input screen with five Inputs set up.

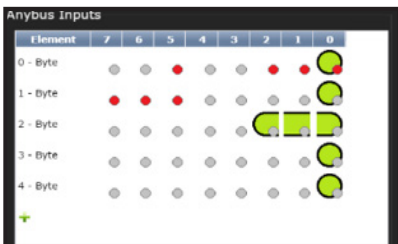



Click on to change an individual Element or return to Input Configuration screen.

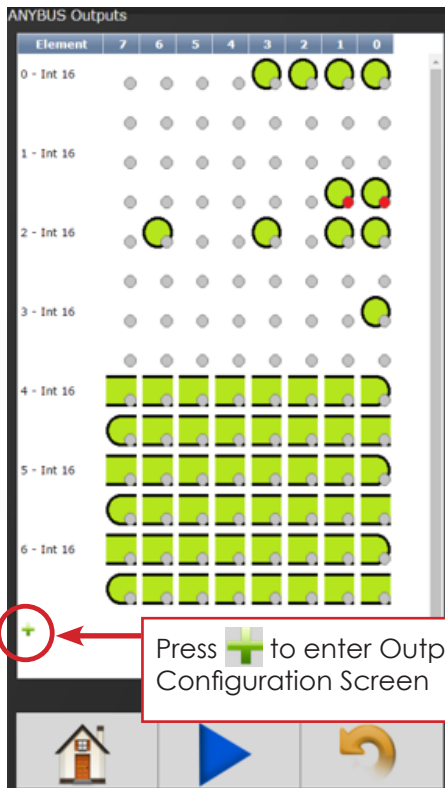

Will delete individual Elements.

4.5.1.4 Anybus/Modbus TCP/Ethernet IP Outputs



Press  to enter Output Configuration Screen

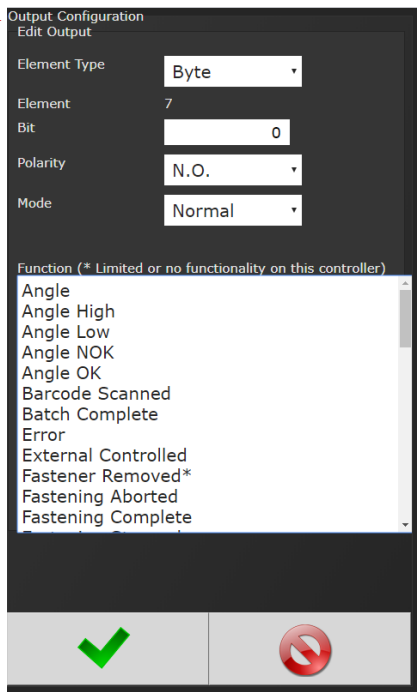

Element Type: Choose from Byte, Int16, Int32, or ASCII.

Element: Shows element # being configured

Bit: Enter Bit #.

Bits (not shown): # of bits the assignment will read.

Start at: Starting bit location.

Polarity: Select Normally Open or Normally Closed Outputs.

Mode:

- **Normal:** Output signal sent.
- **Timed Signal Sent:** Time entered in seconds
- **Flash Signal Sent:** Time entered in seconds

Function: See "11. Assignable I/O" on page 49 for more details on assignable functions.

Click on  after appropriate selections are made.

Example of the Anybus Output screen with five Outputs set up.

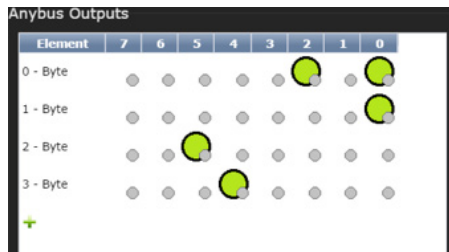

Click on  to change an individual Element or return to Input Configuration screen.

 Will delete individual Elements.

4.5.2 Communication Interfaces

The Communications Menu will vary depending on system configuration.

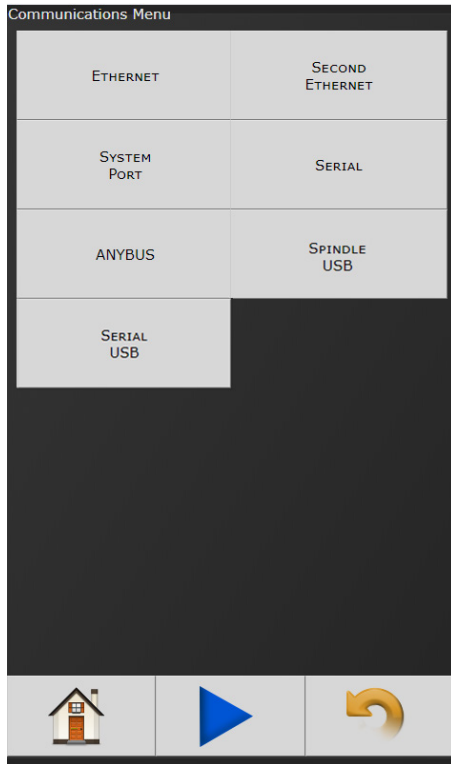

4.5.2.1 Ethernet/Second Ethernet

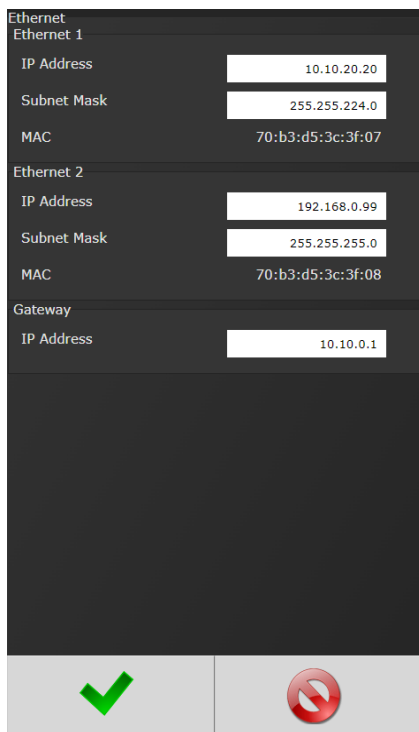

NOTE: Consult your local System Administrator to connect the controller to your Network and assign IP addresses.

IP Address: IP address of controller's Ethernet port.

Subnet Mask: Subnet mask of the controller.

Gateway: Gateway is the IP address of the gateway computer that provides access beyond the local network.

4.5.2.2 System Port

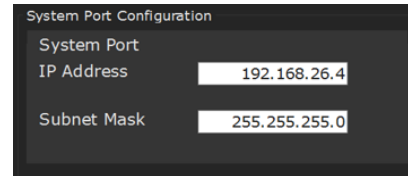

IP Address: The IP address of controller's System Port (Default is 192.168.1.4)

Subnet Mask: The Subnet Mask of controller's System Port.

NOTE: It is not recommended to change this setting.

4.5.2.3 Serial Port

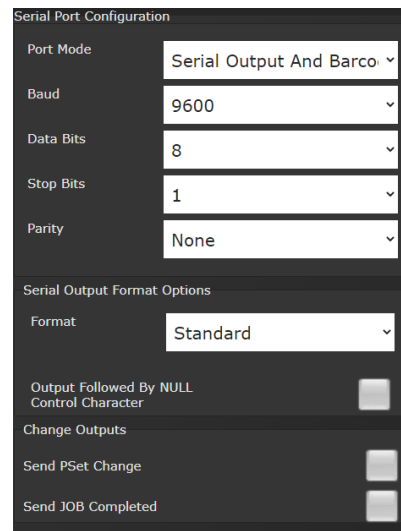

Port Mode: The following modes are available:

- **Serial Output:** A serial data string will be Output in the following format after each rundown:
 - # P 1 BB TTT.T AAAA 0000 0000 J
(Notice the decimal point next to the least significant T)
 - P: Parameter set ("1" – "9") for PSets 1-9, ("A" – "W") for PSets 10-32.
 - B: Job count
 - T: Torque result
 - A: Angle result
 - J: Judgment
@=overall pass, H=low torque, l (eye)=high torque, J=low angle, K=high angle, G=fault during fastening
- **Barcode Reader:** See "5. Barcode Reader Details" on page 40 for Barcode setup.
- **Serial Output and Barcode Reader**
- **Open Protocol**
- **PFCS:** Select from dropdown and configure per hardware requirements
- **PI Line Control:** This is customer specific. Please reference PI Line Control Document on [AIMCO Website/Product Manuals](http://AIMCO.Website/ProductManuals).

Baud: Serial ports can be configured for different baud rates available

- 75, 110, 300, 1200, 2400, 4800, 9600, 19200, 38400, 57600, 115200

Data Bits/Stop Bits/Parity: Configure per hardware requirements

Serial Output Format Options: (see "Serial Output Format Options" on page 29)

- Standard
- Standard with PSet
- UEC Serial Modified
- Profibus
- UEC Serial

Output Followed by Null Control Character: Adds a one-byte NULL character to the end of the serial string. Needed by systems that use the NULL character to signify the end of the string. See following section for more information.

Send PSet Change

- Sends a serial string any time the PSet is changed. String is in the form '%%CAN8X%%CAN4YNAC%%' where X is the previous pset and Y is the new pset. See following section for more information.

Send Job Completed

- Sends a serial string containing "Job Completed" whenever a job has been completed.

Gen IV Serial Port Pin-out

Pin	Signal
1	
2	RX
3	TX
4	DTR
5	GND
6	
7	
8	
9	

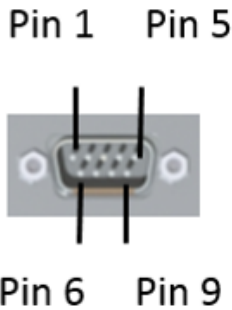

4.5.2.4 Anybus

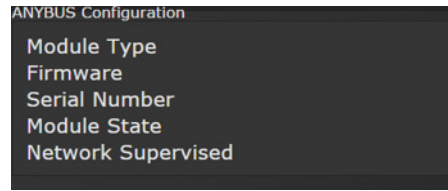

Node Address: Configures the Anybus node address for controller.

4.5.2.5 Spindle USB

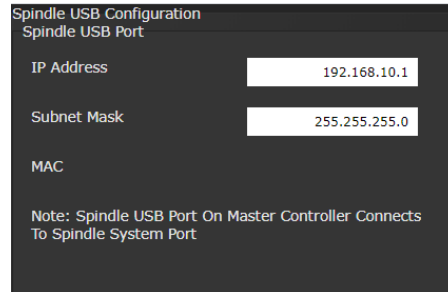

This can be used to set up a 2 spindle network through the USB port.

4.5.2.6 Serial USB

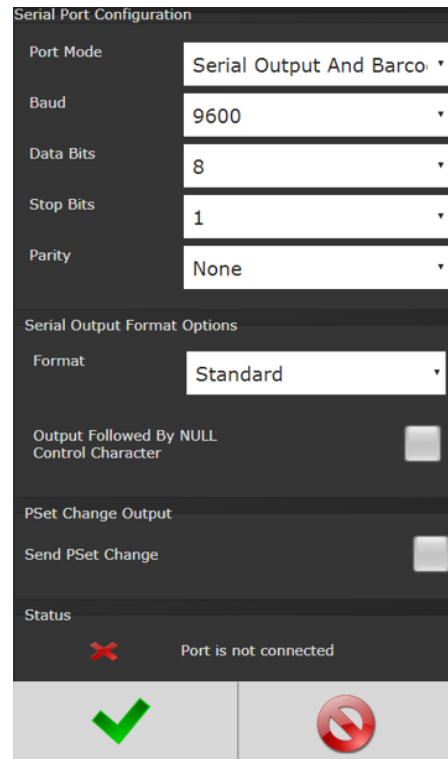

See "4.5.2.3 Serial Port" on page 27 for reference

Serial Output Format Options

Standard Output Format:

- O P HHHHH LLLLL TTTT P HHHHH LLLLL AAAAA CR CR NULL*
 - O: Overall Pass/Fail
 - 'P' = Pass, 'F' = Fail
 - P: Torque Pass/Fail
 - 'P' = Pass, 'F' = Fail
 - HHHHH: Torque High Limit
 - Units selected in the PSet X10
 - LLLLL: Torque Low Limit
 - Units selected in the PSet X10
 - TTTT: Torque Result
 - Units selected in the PSet X10
 - P: Angle Pass/Fail
 - 'P' = Pass, 'F' = Fail
 - HHHHH: Angle High Limit
 - Degrees
 - LLLLL: Angle Low Limit
 - Degrees
 - AAAAA: Angle Result
 - Degrees
 - CR: Carriage return control character
 - CR: Carriage return control character
 - NULL*: Null control character (*if option is selected)

Standard Output with Carriage Return, Line Feed and PSet Format:

- O P HHHHH LLLLL TTTT P HHHHH LLLLL AAAAA T CR LF NULL*
 - O: Overall Pass/Fail
 - 'P' = Pass, 'F' = Fail
 - P: Torque Pass/Fail
 - 'P' = Pass, 'F' = Fail
 - HHHHH: Torque High Limit
 - Units selected in the PSet X10
 - LLLLL: Torque Low Limit
 - Units selected in the PSet X10
 - TTTT: Torque Result
 - Units selected in the PSet X10
 - P: Angle Pass/Fail
 - 'P' = Pass, 'F' = Fail
 - HHHHH: Angle High Limit
 - Degrees
 - LLLLL: Angle Low Limit
 - Degrees
 - AAAAA: Angle Result
 - Degrees
 - 1: PSet
 - PSet('1' - '9') for PSets 1-9, ('A' - 'Z') for PSets 10-35
 - CR: Carriage return control character
 - LF: Line feed control character
 - NULL*: Null control character (*if option is selected)

UEC Serial Modified Format (matches some Gen4 earlier versions):

- # P 1 BB TTT.T AAAAA PPPP 0000 J CR NULL*
 - #: Message Start
 - P: PSet
 - PSet('1' - '9') for PSets 1-9, ('A' - 'Z') for PSets 10-35
 - 1: Spindle Number (Always 1)
 - BB: Job Bolt Count
 - Total number of accepts during the Job
 - TTT.T: Torque Result
 - Units selected in the PSet
 - AAAAA: Angle Result
 - Degrees
 - PPPP: Pulse Count
 - 0000
 - J: Judgment
 - '@' = Overall Pass, 'H' = Low Torque, 'I' = High Torque, 'J' = Low Angle, 'K' = High Angle, 'G' = Fault During Fastening
 - CR: Carriage return control character
 - NULL*: Null control character (*if option is selected)

Profibus Output Format:

- %CAN 1 O P HHHHH LLLLL TTTT P HHHHH LLLLL AAAAA NAC% CR LF NULL*
 - %CAN: Message Start
 - 1: PSet
 - PSet('1' - '9') for PSets 1-9, ('A' - 'Z') for PSets 10-35

- O: Overall Pass/Fail
 - 'P' = Pass, 'F' = Fail
- P: Torque Pass/Fail
 - 'P' = Pass, 'F' = Fail
- HHHHH: Torque High Limit
 - Units selected in the PSet X10
- LLLLL: Torque Low Limit
 - Units selected in the PSet X10
- TTTT: Torque Result
 - Units selected in the PSet X10
- P: Angle Pass/Fail
 - 'P' = Pass, 'F' = Fail
- HHHHH: Angle High Limit
 - Degrees
- LLLLL: Angle Low Limit
 - Degrees
- AAAAA: Angle Result
 - Degrees
- NAC%: Message End
- CR: Carriage return control character
- LF: Line feed control character
- NULL*: Null control character (*if option is selected)

UEC Serial Format (matches UEC 4800 and Gen3):

- # 1 P BB TTT.T AAAAA PPPP 0000 J CR NULL*
 - #: Message Start
 - 1: Spindle Number (Always 1)
 - P: PSet
 - PSet('1' - '9') for PSets 1-9, ('A' - 'Z') for PSets 10-35
 - BB: Job Bolt Count
 - Total number of accepts during the Job
 - TTT.T: Torque Result
 - Units selected in the PSet
 - AAAAA: Angle Result
 - Degrees
 - PPPP: Pulse Count
 - L = Low Pulse Count, M = High Pulse Count
 - 0000
 - J: Judgment
 - '@' = Overall Pass, 'H' = Low Torque, 'I' = High Torque, 'J' = Low Angle, 'K' = High Angle, 'G' = Fault During Fastening, '*' = None of these conditions apply
 - CR: Carriage return control character
 - NULL*: Null control character (*if option is selected)
- 'CSV String'
 - S01,JB01, TTT.T, S, AAA.A, S, O, MM/DD/YYYY HH:MM:SS, VVV<CR><LF>
 - S01: Spindle number
 - JB01: Job number
 - TTT.T: Torque
 - S: Torque Status (A = OK, H = High, L = Low)
 - AAA.A: Angle
 - S: Angle Status (A = OK, H = High, L = Low)
 - O: Overall Status (A = OK, R = NOK)
 - MM: Month
 - DD: Day
 - YYYY: Year
 - HH: Hour
 - MM: Minute
 - SS: Second
 - VVV: 32 character barcode ID
 - <CR>: Carriage Return
 - <LF>: Line Feed

'Output Followed by NULL Character':

- The NULL characters can be seen by using PUTTY and connecting to the controller in 'Raw' mode. Then set logging to log all output and check the log to see the NULL characters.

'Send PSet Change':

- PSets up to 9 match the number, 10-35 are A-Z, greater than 35 is '*':
 - %%CAN8X%%CAN4YNAC%%
 - X: Last PSet
 - Y: New PSet

4.5.3 Protocols

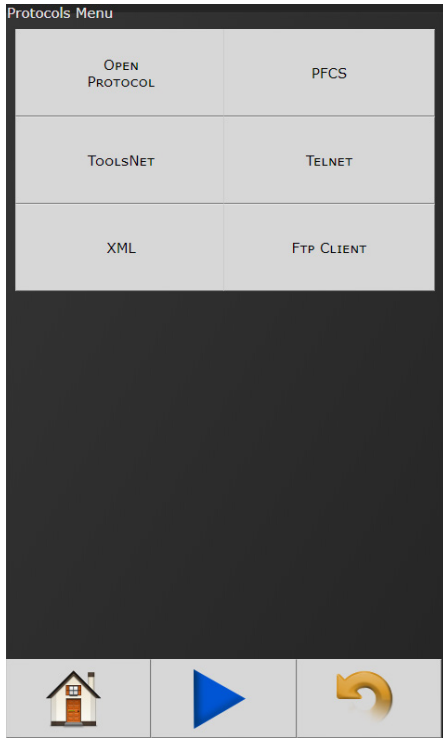

For information about these settings, see individual protocol instructions on AIMCO's website at www.aimco-global.com/manuals.

4.5.4 Front Panel Buttons

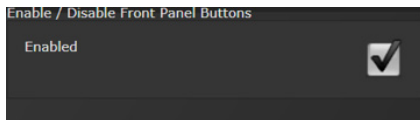

Enable/ Disable front panel buttons on controller console.

4.5.5 Power Up

Allows user several "Job" choices upon controller Power Up:

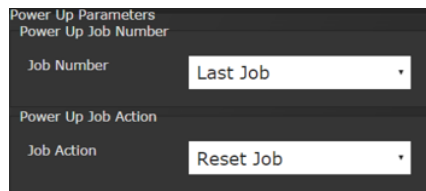

Power Up Job

Number: Controller will power up on the job # selected. When "Last job" is selected, controller will power up on last job selected prior to being Powered Down.

- **Last Job:** Controller will default to last job performed.

Power Up Job Action

- **Reset Job:** Job will be reset when controller is Powered Up.
- **Wait for Job Reset:** Controller will wait for an External Job reset command upon Power Up and will retain job information existing prior to power down.
- **Resume Last Job:** Upon Power Up, tightening sequence will resume at the next fastening from the point in the job when power was shut down.

4.5.6 Bar Code Setup

Required Identifiers for Tool Enable: Selects which four Identifiers (ID#1-4) are required to enable tool.

Reset identifiers for Job Complete: Selects which four Identifiers (ID#1-4) to reset on a job complete. Select Identifiers by clicking on them.

Block New Identifiers While Job is Running: Check to enable feature that ignores any barcode scanning while a JOB is in progress

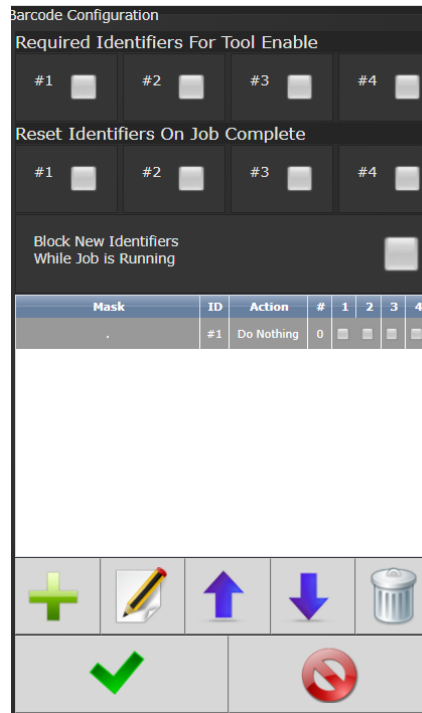

Step 2: Enter appropriate information on Barcode ID Configuration Screen.

Identifier Mask: The Mask is a string used to compare the received barcode against. The received barcode must be at least as long in length as the Mask. The Mask can also contain "don't care" characters of a decimal point or period in the string. These characters are counted in the length, however, the actual received character in that position doesn't matter.

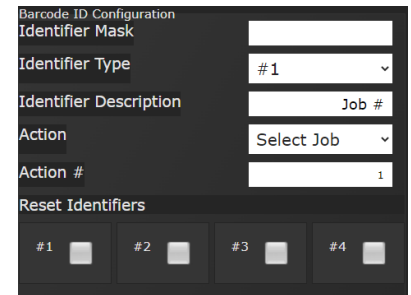

Example:



VIN# 123456

Identifier Type: Identifies which identifier (ID# 1-4) received barcode will be stored into.

Identifier Description: Text field can be used to give a description to each identifier type. (Example: Vehicle).

Action: Action executed by controller when barcode with a matching identifier mask is scanned. The actions are:

- Do Nothing
- Select Job (This will require a Job to be configured on the JOB page when using this option)
- Select PSet

Action #: When Select Job or Select PSet is selected, this is the number of the Job or PSet that will be selected.

Reset Identifiers: Can reset other identifiers (ID# 1-4) when barcode is received. Click on identifiers to reset.

Step 3: Press  to save and re-enter completed barcode configuration screen.

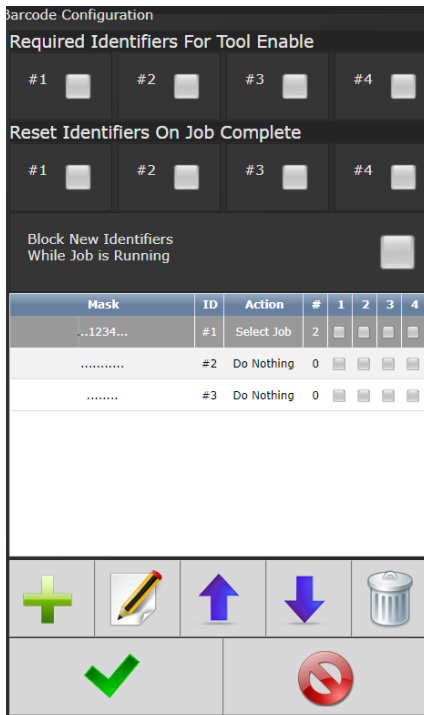

Barcode Configuration

Required Identifiers For Tool Enable





#1 #2 #3 #4



Reset Identifiers On Job Complete

#1 #2 #3 #4

Block New Identifiers While Job is Running

Mask	ID	Action	#	1	2	3	4
...1234...	#1	Select Job	2	<input type="checkbox"/>	<input type="checkbox"/>	<input type="checkbox"/>	<input type="checkbox"/>
.....	#2	Do Nothing	0	<input type="checkbox"/>	<input type="checkbox"/>	<input type="checkbox"/>	<input type="checkbox"/>
.....	#3	Do Nothing	0	<input type="checkbox"/>	<input type="checkbox"/>	<input type="checkbox"/>	<input type="checkbox"/>

Click anywhere in body if additional identifiers are required.

Press  to save barcode configuration.

See "5. Barcode Reader Details" on page 40 for more information)

To configure Serial Port for Barcode Reader: On Home page click Controller → Communication Interfaces → Serial

Select Barcode Reader and the correct Baud rate.

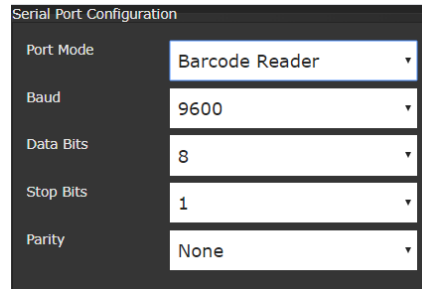

Serial Port Configuration

Port Mode: Barcode Reader

Baud: 9600

Data Bits: 8

Stop Bits: 1

Parity: None

Press  to save changes.

4.5.7 Set Time

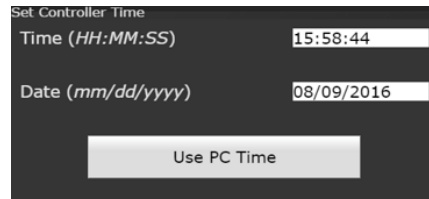

Set Controller Time

Time (HH:MM:SS): 15:58:44

Date (mm/dd/yyyy): 08/09/2016

Use PC Time

Set time and date. If connected to a PC, use PC Time to set controller time.

4.5.8 Remote Connections

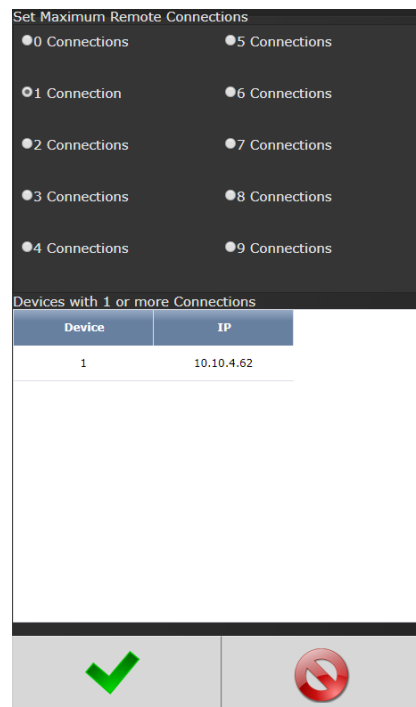

Set Maximum Remote Connections

0 Connections
 5 Connections

1 Connection
 6 Connections



2 Connections
 7 Connections

3 Connections
 8 Connections

4 Connections
 9 Connections

Devices with 1 or more Connections

Device	IP
1	10.10.4.62

Sets number of remote browser connections to controller.

4.5.9 Lock Tool on Reject

When enabled, the tool will be disabled after an NOK rundown. The tool can be enabled with the "Remove Lock on Reject" assignable input.

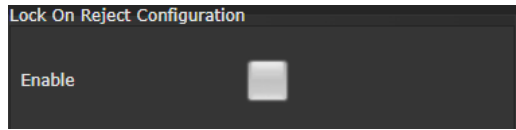

4.5.10 Tool Pairing

See "3.2 Pairing iBC-Z Controller to Uryu UBX-AF Tool" on page 8.

4.5.11 Languages

Select from:

- English
- Chinese
- Japanese
- Korean
- Spanish
- Portuguese

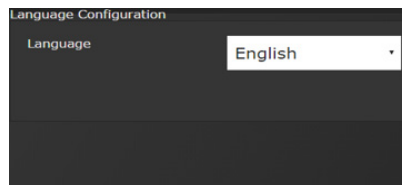

4.6 Accessories

Type	IP	Enabled
Smart Arm	192.168.100.5	✓

This screen shows accessories configured in the controller. New accessories can be added, edited, and deleted using the buttons at the bottom of the table. The gear icon navigates to the Accessory Scanning and Setup page.



The Smart Arm Accessory allows an articulated arm with encoders to be used

with the Gen IV controller. Fastener locations can be programmed into the controller so that the

controller will perform specific actions when the tool is located on a specific fastener.

For more specific instruction contact: **AIMCO Technical Service, Toll Free 1-800-852-1368** or go to www.aimco-global.com/Manuals and download the **Gen-IV Controller Smart Arm Configuration Manual**.

4.7 Diagnostics

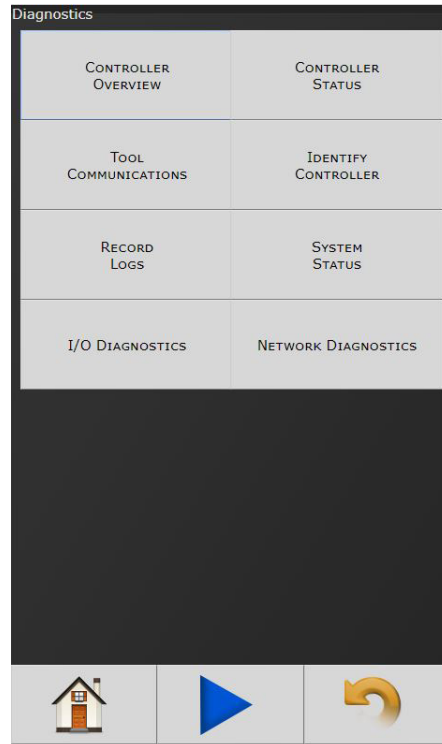

The Diagnostics menu contains all pertinent information regarding unusual behavior of the system. Detailed descriptions are given below.

4.7.1 Controller Overview

Model Number:
Model Number of the controller.

Serial Number:
Serial Number of the controller.

Type: Type of controller:

- **IBCZ4:**
Intelligent Battery Tool Controller

SYSREL: System Release # shown

Application:
Current Application software version.

Firmware: Current Firmware software version.

Available Hardware: Available hardware on the controller.

Controller Overview	
General	
Model Number	IBC4-ZTU
Serial Number	654321
Type	IBCZ4
Software Versions	
SYSREL	2R20B1
Application	1.119.1
Firmware	01.74
Available Hardware	
LED Display	
Touch Screen Display	
IO: 8 Inputs Sinking, 8 Outputs Relay	
24Vdc Power Supply	
Serial Port	
ANYBUS	
Ethernet	
Second Ethernet	
Mainboard 1.8Vdc	
9V Power Supply	

- **5 Vdc:** Represents voltage from 5V power supply powering controller electronics.
- **3.3 Vdc:** Represents controller electronics internal 3.3V Bus voltage.
- **SOM 1.8 Vdc:** Represents controller electronics internal 1.8V Bus voltage
- **Mainboard 1.8 Vdc:** Represents controller electronics internal 1.8V Bus voltage

CPU Temperature (°C): Represents temperature of CPU measured in Celsius.

Mainboard Temperature (°C): Represents temperature inside controller measures in Celsius.

Active Faults: Any tool/ controller faults will be shown in this area.

4.7.3 Tool Communications

Shows real time communication between iBC-Z controller and tool

Tool Communications	
Rx: ASEN;01;16290003;4;OK;9916; <d> <a>	
Tx: RSEN;01;16290003;0004;0001;00000000;00000001;000000000000.	
Tx: AGRA;02;16290003;0006;OK;14e2; <d> <a> <0>	
Rx: RGRA;02;16290003;6;OK;5142;1;3;1;0;3;2;1;0;2001;396;396;729;	
Tx: ASIO;01;16290003;0005;OK;e0ee; <d> <a> <0>	
Rx: RSIO;01;16290003;5;1;0000;00000000000000000000;0;1;1;5142;..	
Rx: ASEN;01;16290003;3;OK;A9CA; <d> <a>	
Tx: RSEN;01;16290003;0003;0001;00000000;00000001;000000000000.	
Tx: AGRA;02;16290003;0004;OK;026a; <d> <a> <0>	
Rx: RGRA;02;16290003;4;OK;5141;1;3;1;0;3;2;1;0;2006;281;281;562;	
Tx: ASIO;01;16290003;0003;OK;db76; <d> <a> <0>	
Rx: RSIO;01;16290003;3;1;0000;00000000000000000000;0;1;1;5141;..	
Rx: ASEN;01;16290003;2;OK;A28E; <d> <a>	
Tx: RSEN;01;16290003;0002;0001;00000000;00000001;000000000000.	
Tx: AGRA;02;16290003;0002;OK;39f2; <d> <a> <0>	
Rx: RGRA;02;16290003;2;OK;5140;1;3;1;0;3;2;1;0;2001;344;344;653;	
Tx: ASIO;01;16290003;0001;OK;cdfc; <d> <a> <0>	
Rx: RSIO;01;16290003;1;1;0000;00000000000000000000;0;1;1;5140;..	
Rx: ASEN;01;16290003;1;OK;BF42; <d> <a>	
Tx: RSEN;01;16290003;0001;0001;00000000;00000001;000000000000.	
Tx: AMSG;01;16290003;0000;OK;880e; <d> <a> <0>	
Status:Screwdriver status: ready	
Status:(Reserved) CTRL	
Status:0	
Message:Start-up phase	
Message:WLAN OK	
Rx: RMSG;01;16290003;0;1;0000000000000009;0000000000005080;0;	
Tool 1 connected	

4.7.2 Controller Status

Controller Status	
Bus Voltages	
24 Vdc	OK
9 Vdc	9.00
5 Vdc	4.89
3.3 Vdc	3.24
SOM 1.8 Vdc	1.82
Mainboard 1.8 Vdc	1.79
Torque Vdc	0.00
Temperatures	
CPU Temperature (° C)	26
Mainboard Temperature (° C)	34
Active Faults	

Shows "Live" status of controller, voltages, active faults, and temperature.

Bus Voltages: Alarm icon will appear on controller console and under "Active Faults" (see below) if any of these values are out of range:

- **24 Vdc:** Represents voltage from 24V power supply. Value is reported as on or off (.0-24.0 volts) and is for external use via 24V I/O port.

4.7.4 Identify Controller

'Identify Controller' will cause lights on controller and tool to flash making the system easy to locate. This is especially helpful when programming is being done and multiple controllers are being used in close proximity to each other.

4.7.5 Record Logs

Log Records	
CHANGE	INFORMATION
ERROR	ALL

Logs information describing usage of controller and tools that have been used with that controller.

4.7.5.1 Change Log

Log displays changes made to tool or controller.

4.7.5.2 Information Log

Log displays all information entries.

4.7.5.3 Error Log

Log displays ONLY Error Entries.

4.7.5.4 All

Displays all Changes, Information and Error entries.

4.7.6 System Status

System Status		
Memory Usage		
Startup	Current	Increase
215712	246552	14.30%
Internal Storage		
KB Allocated	KB Available	KB Used
15620038	10934784	30%
USB Flash Drive		
KB Allocated	KB Available	KB Used
0	0	0

4.7.7 I/O Diagnostics

The I/O Diagnostics screen shows a log of all IO state changes from any assignable input or output. This can aid in verifying the correct functionality for IO configuration.

Assignable I/O Diagnostics			
I/O	Bus	Assignment	I/O State
Out	24v	Job Complete	0
Out	24v	Angle Low	0
Out	24v	Angle High	0
Out	24v	Torque Low	0
Out	24v	Torque High	0
Out	24v	NOK	0
Out	24v	OK	0

The refresh button will update the screen with the most recent IO changes. The save button will generate a log file that can be viewed on a PC. This file can be downloaded when viewing from a PC or saved to a USB drive when using the controller touch screen. This saved CSV file contains much more detailed information (timing, IO settings, etc) than can be displayed on the controller screen.

4.7.8 Network Diagnostics

Network Diagnostics can be useful in troubleshooting Ethernet communication issues

Network Diagnostics	
Ethernet	
Ethernet 1	State Address up 10.10.5.50
Ethernet 2	down
Test Connection	
IP Address	<input type="text" value="0.0.0.0"/> <input type="button" value="Ping"/>
Capture	
Interface	<input type="text" value="All"/>
Number of Packets	<input type="text" value="100"/>
<input type="button" value="Start Capture"/>	

Ethernet: Shows if the Ethernet port is physically connected and if the hardware is operational.

Test Connection: Provides a way to check the ethernet connection to other devices on the same network.

Capture: Captures and saves the ethernet traffic for

evaluation
Interface (pull down menu)

- All
- Ethernet 1
- Ethernet 2

4.8 Login

When a password is required it can be entered in this screen.

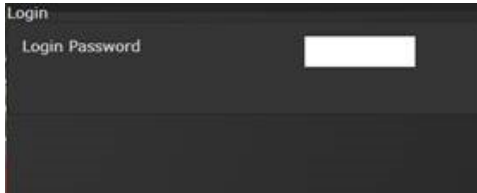

Three levels of access to the controller are available:

- **Operator:** Run/Login screens available.
- **Technician:** Run/PSet/Job/Diagnostics and Login screens available.
- **Administrator:** All screens available.

4.9 Advanced

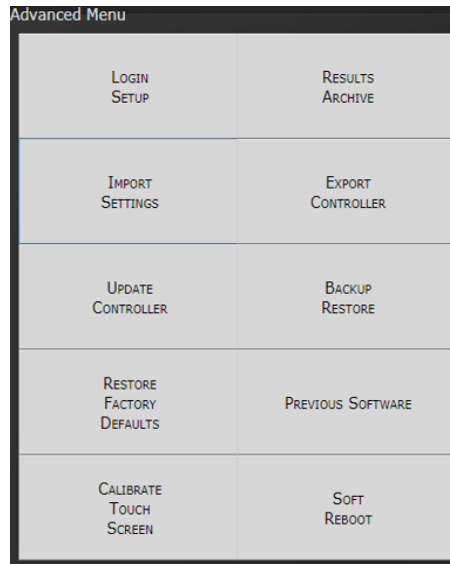

The 'Advanced' menu handles complex settings within the controller. Detailed descriptions are given in the following sections.

4.9.1 Login Setup

This screen allows the user to select the default Login level upon controller start up.

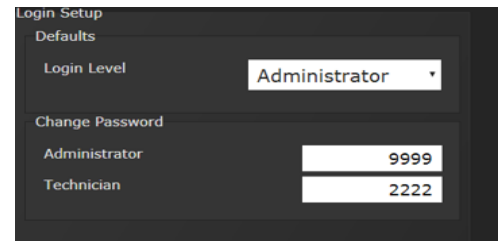

- **Operator**
- **Technician**
- **Administrator**

4.9.2 Results Archive

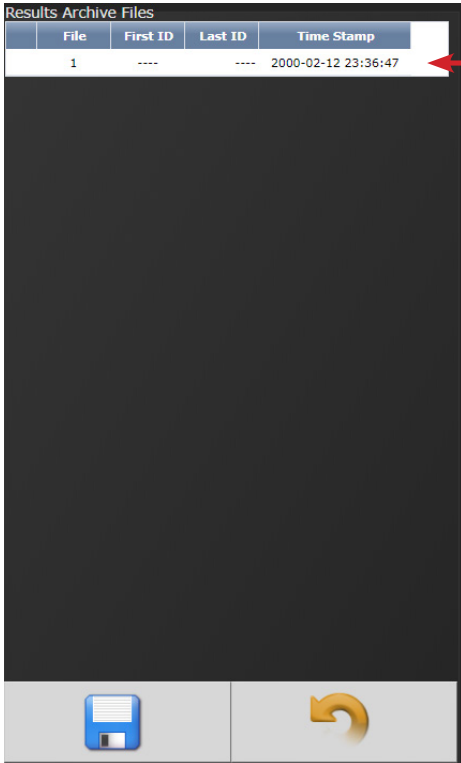

Select a file and press 

Approximately one million rundowns can be stored. Twenty files with approximately 50,000 rundowns are maintained at a time. The user can, at any time, save the runs to either a USB stick or to the Web as a CSV file imported directly into an Excel spreadsheet.

Using the touchscreen console, you can select multiple files to save.

Using the web option, you can select one of these files at a time to save (web option is default).

Select either USB or Web Archive location

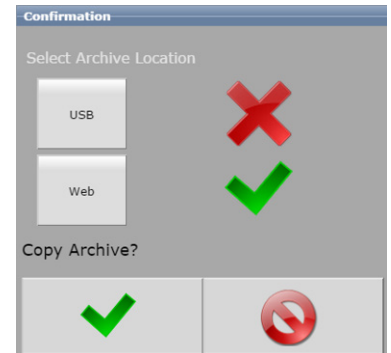

Example of Saved Excel File

Rundown	Job Num	Job Name	Sequence	Bolt count	Status	Date	Time	Torque	Status	Angle	Status	PSet Num	PSet Name	Tool Mode	Tool Serial	Id1 (ID #1)	Id2 (ID #2)	Id3 (ID #3)	Id4 (ID #4)
2068	0		0	0	P	#####	11:13:42	5.08	P	480	--	1			0				
2069	0		0	0	P	#####	11:13:49	5.054	P	535	--	1			0				
2070	0		0	0	P	#####	11:13:50	5.002	P	450	--	1			0				
2071	0		0	0	P	#####	11:13:52	5.013	P	595	--	1			0				
2072	0		0	0	P	#####	11:13:53	5.085	P	495	--	1			0				
2073	0		0	0	P	#####	11:13:54	5.1	P	440	--	1			0				
2074	0		0	0	P	#####	11:13:56	5.089	P	575	--	1			0				

4.9.3 Import Settings

This allows the user to download any previously saved settings onto the controller (refer to 'Export Controller' for help with saving data).

1. Plug the USB with an export file into any port on the controller.
2. From the Home screen, navigate to Advanced → Import Settings.
3. Select the settings to be checking the

corresponding box 

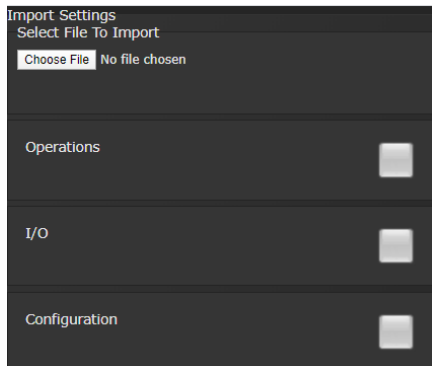



Operations: This includes PSets and Jobs.

I/O: This includes I/O settings for the local I/O, Anybus, Modbus, and EtherNet/IP.

Configuration: This includes all settings of the controller except I/O, Master Spindle, Rundowns, PSets or Jobs.

Spindle: This includes any Master Spindle setup (i.e. number of spindles, IP addresses, etc).

4. Press  to accept the changes.
5. Press  to proceed.
6. Press  when the import is complete and the controller will restart.

Import settings that were exported from another controller via a USB flash drive. Use this to quickly apply the same settings across several controllers. For example, it is common to have multiple controllers with the same I/O configuration. Set up one controller with the correct I/O configuration and export the controller from Advanced → Export Controller. Now the I/O settings can be imported using this screen.

NOTE: Setting can only be imported from controllers running the same version of software.

4.9.4 Export Controller

This allows the user to save Configuration, Operations, I/O, and Spindle settings onto a USB flash drive.

1. Plug a USB into any port on the controller.
2. From the Home screen, navigate to Advanced → Export Controller.
3. Press  to continue, and the controller will begin the export process.

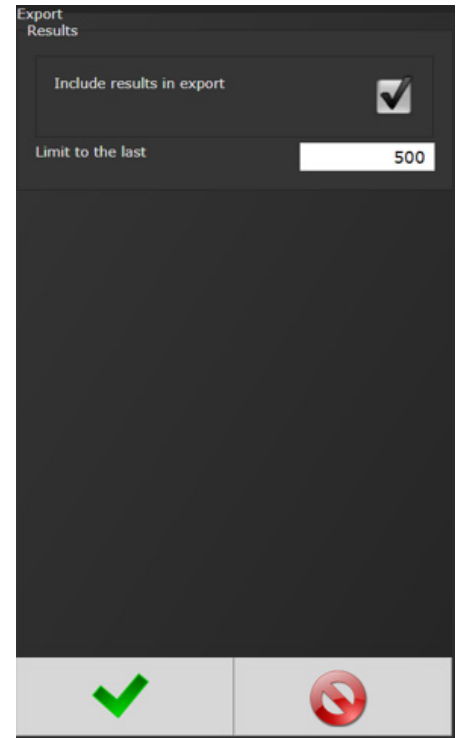

4. Press  to complete the export.

4.9.5 Update Controller

NOTE: Updated firmware versions will typically be sent via email zip file. Always save PSet and IP address information before upgrading controller.

Upgrading the AIMCO Gen IV Controller

Using the TouchScreen or a System Port browser session, navigate to the 'Advanced' menu. Click 'Update Controller.'

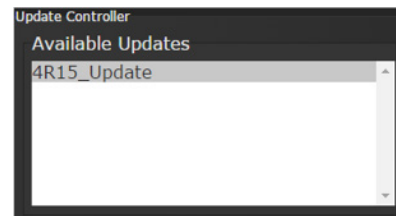

If a USB stick containing the zip file has been plugged in to the controller, the file will show in the Available Updates

list. Select the latest release and click  when ready.

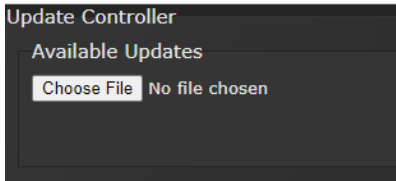

If updating through a system port browser session, a dialog box will appear. Click the Choose File button

and navigate to the folder where the zip file is located on the computer. Select the latest release and click when ready.

After the controller restarts, the user should see following messages

Updating System
Do not unplug USB
Do not Power Off Controller
This may take a few minutes...

Controller Upgrade Notification

When the controller has finished, navigate to Diagnostics → Controller Overview to view any changes to the 'Software Versions'. Any system settings (Ethernet IP address, PSets, Jobs, etc.) will remain unchanged.

4.9.6 Backup Restore

The Backup function allows the user to create an image of the controller software/firmware including all Configurations, Operations, I/O, and Spindle settings. This is used to create a point in which the controller can restore to if the need arises. In that case, the Restore function would be used.

1. From the Home screen, navigate to Advanced → Backup Restore.

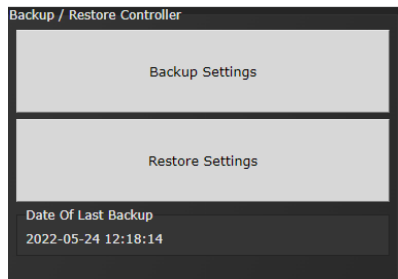

2. Press Backup to initialize the backup process.

3. Press to replace previous backup with current system, the backup process will begin.

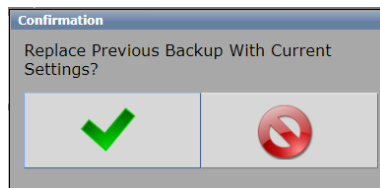

4. Press **Restore** to initialize the restore process.

5. Press to restore all settings and firmware to last backup, the restore process will begin.

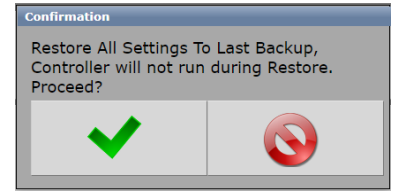

6. The controller will restart when finished.

4.9.7 Restore Factory Defaults

This allows the user to reset the controller's parameters to factory settings

- From the Home screen, navigate to Advanced → Restore Factory Defaults.
- Select the settings to be changed and accept

- **Operations:**

This includes PSets and Jobs.

- **I/O:**

This includes I/O settings for the local I/O, Anybus, Modbus, and EtherNet/IP.

- **Configuration:**

This includes all settings of the controller except I/O, Master Spindle, Rundowns, PSets or Jobs.

- **Results:**

This includes all rundown data / information

- **Log:**

This includes the Change, Information, Error, and Combined logs.

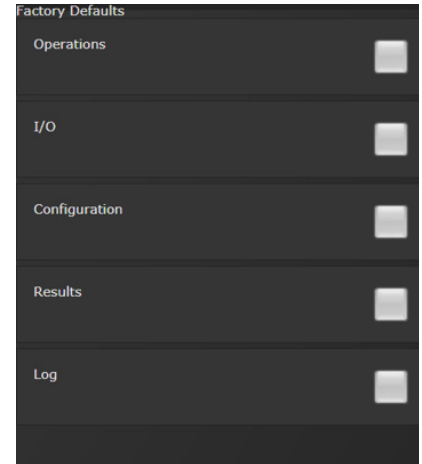

3. Press to accept the changes.

4. Press to proceed.

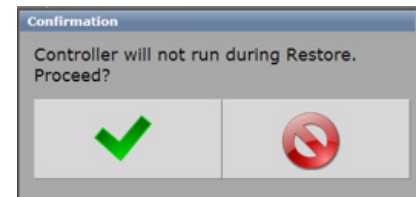

5. Press when the calibration is complete, the controller will restart.

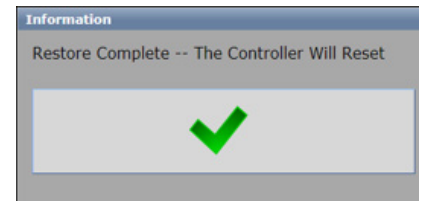

4.9.8 Previous Software

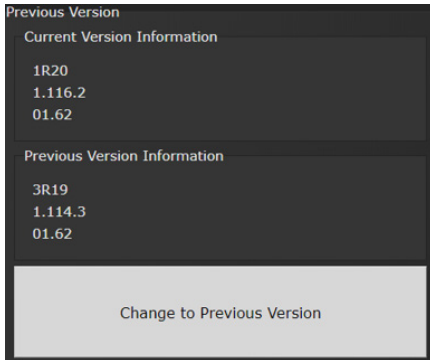

The 'Previous Software' page enables users to change the software to an alternate version. When the controller is updated, the previous version will be retained to easily revert

versions. Settings are not affected. Any changes to settings are retained when changing to an alternate version. The screen shows the current version along with the version information of the alternate version.

This feature is only available for versions 3R19 going forward. It is not possible to revert to a release earlier than 3R19.

4.9.9 Calibrate Touch Screen

Custom and Factory default calibration are available on the controller console.

1. From the Home screen, navigate to Advanced → Calibrate Touch Screen.
2. Press to disable the tool.
3. Select the desired calibration

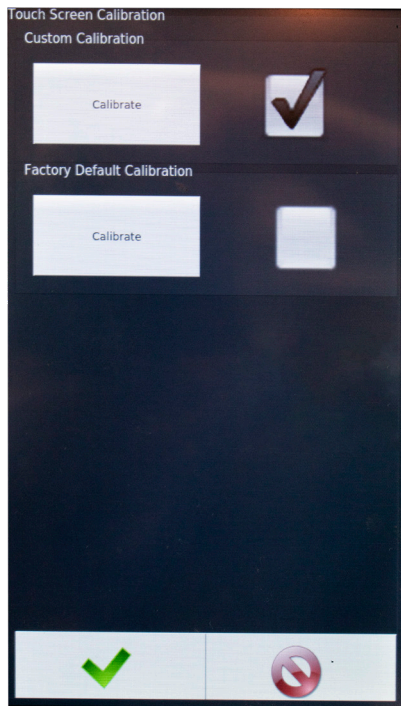

Custom Calibration: This allows the user to create a custom calibration setting for the touch screen.

Factory Default Calibration: This calibrates the touchscreen to the factory defaults.

4. Press to accept the selection.
5. Press to proceed.

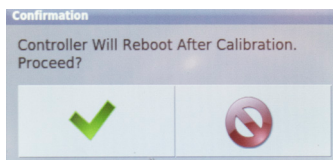

In the case of custom calibration, a screen will appear with instructions on how to increase precision.

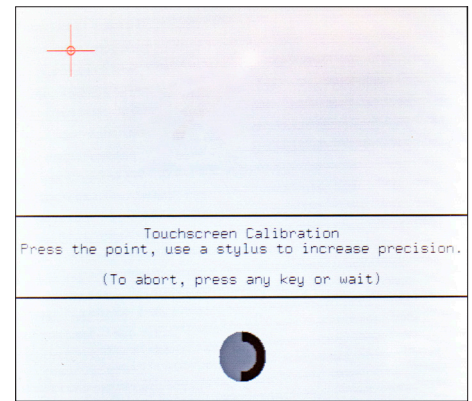

6. Press when the calibration is complete, the controller will restart.

NOTE: The controller may need to be reset before the custom calibration is possible.

4.9.10 Soft Reboot

Restart the controller without turning the power off.

1. From the Home screen, navigate to Advanced → Soft Reboot.
2. Press to proceed, the controller will restart.

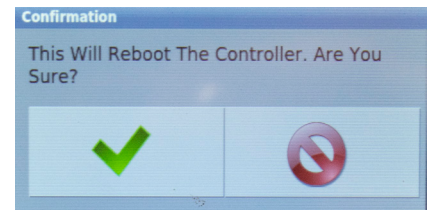

4.10 Statistics

Enter the desired number of samples and PSET to observe calculated statistics. Number of samples must be equal to or less than the existing recent results stored within the controller. Statistics are presented as a courtesy to users who wish to review them in quick fashion on the controller screen.

Statistics, 30 Samples		
	Torque	Angle
Min	0.170 FtIb	0 °
Max	48.360 FtIb	858 °
Range	48.190 FtIb	858 °
Low	--	--
Ok	--	--
High	--	--
\bar{x}	21.535 FtIb	251.2 °
σ	20.873 FtIb	251.0 °
$\bar{x} - 3\sigma$	-41.086 FtIb	-501.8 °
$\bar{x} + 3\sigma$	84.155 FtIb	1004.2 °
6σ	125.240 FtIb	1505.9 °
$6\sigma / \bar{x}$	5.816	6.0
Cp	--	--
Cpk	--	--

Sample Size	30
Pset	PSet 1

5. Barcode Reader Details

The Gen IV iBC controller supports the following barcode reader functionality:

- Support up to four identifiers.
- Each rundown result can be associated with up to four identifiers.
- Identifier(s) can be used to select a parameter set or a job.
- Display identifier(s) on controller.
- Ability to lock-out tool until correct identifier(s) is entered.
- Ability to block barcode reads while a job is in progress.
- Barcode reads (identifiers) can come from any or all the following sources:
 - Serial barcode reader
 - Open protocol
 - Fieldbus network
 - Telnet port

Solution

Regardless of the source (serial barcode reader, telnet, fieldbus, or protocol) each new string is passed through the same process:

- All four identifiers are reset to an empty string on power-up.
- Each received barcode is processed through a Barcode Match Table to look for a match, if one is found the barcode is accepted.
- Each fastening will then be associated with the received barcode(s) until a new one is received or they are reset.

Parameters

The parameters that pertain to the processing of barcode strings:

- The Barcode Match Table is used to identify the newly received barcode string.
- Which of the four Identifiers (ID#1-4) are required to enable the tool?
- Which of the four Identifiers (ID#1-4) to reset on a job complete?
- Parameter to disable all barcode reads while a job is in progress. If set, barcode reads will be disabled after the first fastener is ran until job is complete.

Barcode Match Table

The Barcode Match Table is used to identify which barcode has been received. The controller can have up to 99 entries (rows) in the table. Each entry has actions that will be performed when a matching barcode is received. The table is searched from

top to bottom in an attempt to find a matching barcode. If none are found, the barcode is ignored.

Mask

The Mask is a string used to compare against the received barcode. The received barcode must be at least as long in length as the Mask. The Mask can also contain "don't care" characters of a decimal point or period in the string. These "don't care" characters are counted in the length but the actual received character in that position doesn't matter.

Identifier Type

The "Identifier Type" field identifies which identifier (ID#1-4) the received barcode will be stored in.

Action

Action can be one of the following:

- None
- Select PS#1-256
- Select Job#1-20

Reset ID

The "Reset ID" has the ability to reset other identifiers (ID#1-4) when barcode is received.

Examples:

Operator Scans

When a vehicle enters the station, the operator scans the VIN. The controller selects the correct job number and enables the tool. Each fastener will be identified with this VIN stored locally, and/or sent to a server for storage. The job settings will disable the tool when the job is complete.

Setup

In this example, there are three possible vehicle types each with its own job. The barcode scan will select the correct job (enabling the tool) and the scan will be stored into ID#1.

Mask	ID type	Action	Reset ID				
			ID#1	ID#2	ID#3	ID#4	
"VIN.....7..."	ID#1	Select Job#	1	No	No	No	No
"VIN.....8..."	ID#2	Select Job#	2	No	No	No	No
"VIN.....9..."	ID#3	Select Job#	3	No	No	No	No

The tool enable/disable will be controlled by the job settings; the correct job will be selected by the barcode scan. The "ID Required to Enable the Tool" feature does not need to be utilized.

Required Identifiers for Tool Enable			
ID#1	ID#2	ID#3	ID#4
No	No	No	No

These settings are irrelevant since the only way to enable the tool is with a new job and the only way to select a new job is to scan a new barcode.

Reset Identifiers on Job Complete			
ID#1	ID#2	ID#3	ID#4
Yes	No	No	No

Examples

This is what the 'Operator Scans' example looks like once set up in the Barcode Configuration Screen (see "4.5.6 Bar Code Setup" on page 30).

Airbag Install

The customer wants to track the serial number of each airbag being installed, as well as the operator installing it. When the operator reports to the station, they will scan their employee ID. When the vehicle comes into the station, the operator scans the VIN of the vehicle and the serial number of the airbag. Once all three scans are received, the tool is enabled. Once the correct number of fasteners are installed, the tool is disabled by the job settings. From that point, the operator only needs to scan the vehicle and the airbag to enable the tool.

Setup

We will assign the employee ID to ID#1, the vehicle VIN to ID#2, and the airbag serial number to ID#3. Scanning a new employee ID will reset the other IDs and force a scan of the vehicle VIN and airbag serial number. The scan of the vehicle VIN will also select the correct job number.

Mask	ID type	Action	Reset ID			
			ID#1	ID#2	ID#3	ID#4
"EMP...."	ID#1	None	No	Yes	Yes	No
"VIN....."	ID#2	Select Job#	1	No	No	No
"SN....."	ID#3	None	No	No	No	No

Once all three scans are received, the tool will be enabled.

Required Identifiers for Tool Enable			
ID#1	ID#2	ID#3	ID#4
Yes	Yes	Yes	No

When job is complete, the vehicle VIN will be reset and the airbag serial number, but not the employee ID; this way subsequent vehicles will only require a VIN and S/N to enable tool.

Reset Identifiers on Job Complete			
ID#1	ID#2	ID#3	ID#4
No	Yes	Yes	No

This is what the Airbag Install example looks like set up in "4.5.6 Bar Code Setup" on page 30.

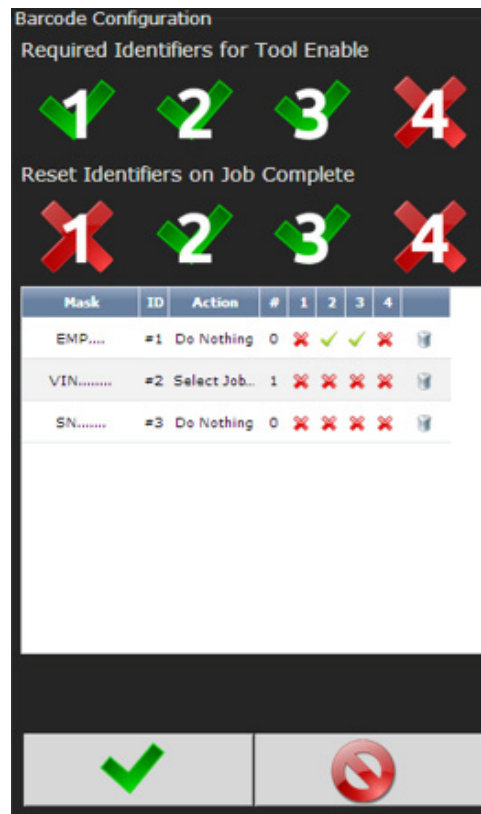





















6. Glossary of Terms

Accept Tone	Controls tone made from handle of handheld tools for accepted fastening cycles.
Angle	Degree fastener rotates from snug, or threshold level, to peak torque.
Cycle Complete	Torque level that determines completion of a fastening cycle.
High Angle	When peak angle recorded exceeds High Angle, the fastening cycle is recorded as a reject for High Angle, the High Angle light (solid yellow) illuminates and fastening cycle is given an overall status of NOK.
High Torque	When peak torque recorded exceeds the High Torque, the fastening cycle is recorded as a reject for High Torque, the High Torque light (solid red) illuminates and fastening cycle is given an overall status of NOK.
High Pulse	When pulse count recorded exceeds the High Pulse, the fastening cycle is recorded as a reject for High Pulse, the High Pulse light (solid yellow) illuminates and fastening cycle is given an overall status of NOK.
Job	A Job is a collection of PSets or Multi-stages, which are useful when performing several multiple fastening operations, each with different requirements. This is convenient since the operator does not have to select a new PSet or Multistage for every fastening.
Low Angle	When the peak angle recorded during the Angle Audit Step fails to reach the Low Angle, fastening cycle is recorded as a reject for Low Angle, the low angle light (flashing yellow) illuminates and fastening cycle is given an overall status of NOK.
Low Torque	When the peak torque recorded fails to reach the Low Torque, fastening cycle is recorded as a reject for Low Pulse, the Low Pulse light (flashing yellow) illuminates and fastening cycle is given an overall status of NOK.
Low Pulse	When the pulse count recorded fails to reach the Low Pulse, fastening cycle is recorded as a reject for Low Torque, the Low Torque light (flashing red) illuminates and fastening cycle is given an overall status of NOK.
Parameter Set	A Parameter Set is a collection of instructions that define how the tool should perform the fastening process. It may be selected from the console or device such as a socket tray or PC

In-Cycle Torque	Controller begins to monitor tool for angle at a preselected threshold torque. Any increase in angle, after the In-Cycle point, results in a corresponding increase in tension or clamp load within the joint.
Speed	Speed at which tool operates during the initial portion of the fastening cycle prior to downshift.
Spindle	A spindle represents a connection to a handheld, or fixtured, tool connected to a controller.
Strategy	Identifies the variables being used to control tool during a fastening.
Threshold Torque	Sets point at which tool is "In Cycle".
Torque Calibration	Determines how torque values are assigned to the electrical signals for torque transducer on tool. Value is unique to each tool and changes over time.
Torque Target	When the tool is being controlled for torque, the torque target instructs controller when to shutoff tool. Torque target should be greater than Low Torque and less than High Torque, this is required for torque control.













7. Icons Defined



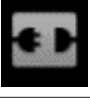



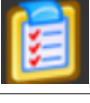
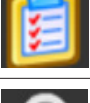



Icon	Description	Function	Where Used
	Home Navigation Button	Navigate to the main menu ("HOME") screen.	All screens except for edit screens.
	Run Navigation Button	Navigate to the Run Screen.	All screens except for edit screens.
	Run Screen Select Buttons	Switch between the different run screen pages.	Run Screen
	Go Back Button	Navigate to one menu level back.	All screens except for edit screens.
	Accept Changes Button	Accept the changes made and return to the parent screen.	Edit screens
	Cancel Changes Button	Reject the changes made and return to the parent screen.	Edit screens
	Add New Button	Add a new item (Pset, Stage, Job, and other).	PSet and Job edit screens.
	Edit Button	Edit selected Item.	PSet and Job edit screens.
	Move Up and Down Buttons	Move selected item up or down in the sequence order.	PSet and Job edit screens.
	Copy Button	Copy selected Items	PSet, Job, and other edit screens.
	Delete Button	Remove or un-assign selected items.	Edit and list view screens.
	Filter Button	Filter Items in a list or table.	List view screens
	Save Button	Save selected item to file.	List view screens
	Select Columns Button	Allows customization of columns shown on the Results Screen.	Results Screen
	Fault Indicator	Fault exists that is preventing the tool from running (can be pressed for more Info).	Run Screen
	Invalid PSet Indicator	Selected Pset does not exist or is not valid.	Run Screen

Icon	Description	Function	Where Used
	Barcode Scan Required Indicator	A barcode is required to enable the tool.	Run Screen
	Job Complete Indicator	Job is complete.	Run Screen
	Lock on Reject (LOR)	Lock tool on rejected fastener.	Run Screen
	Disassembly	A disassembly event has been detected.	Run Screen
	Job Reset Complete	Reset Job has finished. Results from last successful rundown of a job are cleared.	Add New Job Screen

8. Stop Codes

If a Stop condition is detected that prevents the tool from running, a code will appear on the LED display. Any active stop conditions are also displayed on the RUN screen.

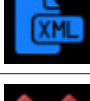
Code	Icon	Description
IO		Stopped or Disabled from Physical 24 volt IO input
ABUS		Stopped or Disabled from ANYBUS
MODB		Stopped or Disabled from Modbus
EIP		Stopped or Disabled from Ethernet IP
RTU		Stopped or Disabled from Modbus RTU
OP		Stopped or Disabled from Open Protocol
OP		Lost Open Protocol Connection
REV		Disassembly Disabled
ARM		Tool Requires Arming – MFB button configured to enable the tool to run.
JOB		Job Sequence Complete
JOB		Job Complete
JOB		XML Count Complete
LOR		Locked on Reject

Code	Icon	Description
BRCD		Bar Code ID scan required to enable tool
SRVC		Tool Disabled For Service - Tool service or calibration interval has expired
INVP		Invalid PSet - Parameter set number for a non-existent Pset has been selected to run. Most likely via one of the following methods: <ul style="list-style-type: none"> o Job o MFB o I/O
INVP		PSet outside of Job - Parameter set number outside of the job has been selected. Most likely via one of the following methods: <ul style="list-style-type: none"> o MFB o I/O
INVJ		Invalid Job - Job number for a non-existent Job has been selected to run. Most likely via one of the following methods: <ul style="list-style-type: none"> o MFB o I/O
PSET		PSet Mismatch
SPND		Spindle Not Configured – Spindle selected to run from a Multi-Spindle Job has not been configured
NET		XML Disconnected
XML		Stop from XML
NOK		XML Max Rejects Exceeded
FLT		Controller Fault - Error has been detected. See fault code list for details

9. Error Codes

If an error condition is detected that prevents the tool from running, a fault code will appear on the LED display. Any active faults are also displayed on GUI RUN screen. Fault history can be viewed in the Controller Error Log.

IBC-Z (URYU ZigBee Tool) Specific Fault Codes

CODE	Fault Type	Description	Possible Causes
BZ01	Zero Check Error	Error reported by the tool	<ul style="list-style-type: none"> Torque sensor deviation under 0-voltage is $\pm 6\%$ or greater at ZERO check
BZ02	Torque Cal Signal out of range	Error reported by the tool	<ul style="list-style-type: none"> Torque sensor deviation under rated strain voltage is $100\pm 6\%$ or greater than CAL value.
BZ03	Setting out of Range	Error reported by the tool	<ul style="list-style-type: none"> Entry in UCC or transfer to UDBP-AFZ such as contradictory setup selection, out-of-range value or impeditive number to interlock.
BZ04	Tool Communication Error	Error reported by the tool	<ul style="list-style-type: none"> Wireless traffic interference
BZ10	Tool CPU Temperature Error	Error reported by the tool	<ul style="list-style-type: none"> Tool's internal temperature exceeded
BZ11	Motor Communication Error	Error reported by the tool	<ul style="list-style-type: none"> UDBP-AFZ internal communication error between control board and motor
BZ12	ZigBee System Error	Error reported by the tool	<ul style="list-style-type: none"> UDBP-AFZ internal control board failed.
BZ13	Torque Sensor Error	Error reported by the tool	<ul style="list-style-type: none"> Tool's internal circuitry damaged or disconnected
BZ14	Angle Sensor Error	Error reported by the tool	<ul style="list-style-type: none"> Tool's internal circuitry damaged or disconnected
BZ15	Battery Error	Error reported by the tool	<ul style="list-style-type: none"> Battery Failure
BZ16	Control System Error	Error reported by the tool	<ul style="list-style-type: none"> Tool's internal circuitry damaged or disconnected
BZ31	Motor Stopped Error	Error reported by the tool	<ul style="list-style-type: none"> Motor Stalled
BT13	Excessive internal temperature	Error reported by the tool	<ul style="list-style-type: none"> Duty cycle too high Faulty Tool electronics
BT14	Motor stopped	Error reported by the tool	<ul style="list-style-type: none"> Tool Stalled
BT15	Spool full	Error reported by the tool	<ul style="list-style-type: none"> Rundown data storage full
BT16	Spool error	Error reported by the tool	<ul style="list-style-type: none"> Rundown data storage faulty
BT17	No data from digital sensor	Error reported by the tool	<ul style="list-style-type: none"> Faulty Tool electronics
BT18	CRC error in program level	Error reported by the tool	<ul style="list-style-type: none"> Programming Download Error
BT19	Error: program level does not exist	Error reported by the tool	<ul style="list-style-type: none"> Programming Error
BT20	User flash error	Error reported by the tool	<ul style="list-style-type: none"> Programming Download Error
BT21	Program sequence error	Error reported by the tool	<ul style="list-style-type: none"> Programming Error
BT22	Torque Sensor Error	Error reported by the tool	<ul style="list-style-type: none"> Tool electronics error

Gen4 Common Hardware Fault Codes

Code	Fault Type	Description	Possible Causes
FH17	1.8vdc MB out of tolerance	Main board 1.8 bus voltage exceeds electrical limits	<ul style="list-style-type: none"> Faulty Controller main board or other Controller electronics
FH18	1.8vdc SOM out of tolerance	System on Module 1.8 bus voltage exceeds electrical limits	<ul style="list-style-type: none"> Faulty Controller main board or other Controller electronics
FH19	3.3vdc out of tolerance	Main board 3.3 bus voltage exceeds electrical limits	<ul style="list-style-type: none"> Faulty Controller main board or other Controller electronics
FH20	5vdc out of tolerance	5 Volt bus voltage out of range	<ul style="list-style-type: none"> Faulty power supply or wiring Faulty Controller main board or other Controller electronics
FH21	9vdc out of tolerance	9 Volt bus voltage out of range	<ul style="list-style-type: none"> Faulty power supply or wiring Faulty Controller main board or other Controller electronics Faulty tool cable Faulty tool electronics or wiring
FH22	24 volt level low	24 Volt I/O power not detected	<ul style="list-style-type: none"> Faulty power supply or wiring Short or other problem with external connections to the 24Volt I/O port.
FH23	Controller temp high	Controller's internal temperature exceeds limit	<ul style="list-style-type: none"> Ambient air temperature exceeds rating of Controller
FH24	+15vdc out of tolerance	+15 Volt bus voltage out of range	<ul style="list-style-type: none"> Faulty power supply or wiring Faulty Controller main board or other Controller electronics Faulty tool cable Faulty tool electronics or wiring
FH25	-15vdc out of tolerance	-15 Volt bus voltage out of range	<ul style="list-style-type: none"> Faulty power supply or wiring Faulty Controller main board or other Controller electronics Faulty tool cable Faulty tool electronics or wiring
FH32	Processor Fault	RTOS processor not communicating with the Application processor	<ul style="list-style-type: none"> Faulty mainboard electronics RTOS processor firmware corrupted or not loaded Faulty SOM board or connector

10. 24 Volt I/O

Port Pinout and Diagrams

An I/O wiring adapter kit is available (Part #27348) from AIMCO to make connection to I/O port on the controller easier. Contact your AIMCO Sales Representative for ordering information. Toll Free: 1-800-852-1368.



Pin #	Function	Default Assignment
1	Output 1	Torque Low
2	Output 2	Angle High
3	Output 3	Angle Low
4	Output 4	Job Complete
5	Outputs 1-4 common	
6	Input 1	
7	Input 2	
8	Input 3	Disable Tool
9	Input 4	PSet Bit 1
10	Input 5	PSet Bit 2
11	Input 6	PSet Bit 3
12	Input 7	Reset Job
13	Input 8	
14	Output 5	Torque Low
15	Output 6	Angle High
16	Output 7	Angle Low
17	Output 8	Job Complete
18	Outputs 5-8 common	
19	N/C	
20	N/C	
21	24 V Return	
22	24 V Return	
23	+24 Vdc	
24	+24 Vdc	
25	+24 Vdc	

NOTE: The Default Assignments in Table above are factory defaults and can be changed. See "11. Assignable I/O" on page 49.

24 Volt I/O Connections

Turn off system before connecting to the LOGIC I/O port. There may be risk of damaging the controller.

- **24Vdc Supply:** The internal 24Vdc power can supply up to 1 amp.
- **Inputs:** Inputs are a sinking configuration with the common connected to the ground pins. 24Vdc is logic ON and 0Vdc is logic OFF.
- **Outputs:** Outputs are normally open relay contacts. The relays are rated for 24Vdc, 1 amp.

NOTE: If Outputs are driving an inductive load, such as a solenoid or large relay, it is recommended to add a diode in parallel with the load to prevent voltage surges.

LOGIC I/O INPUT CONNECTION EXAMPLE

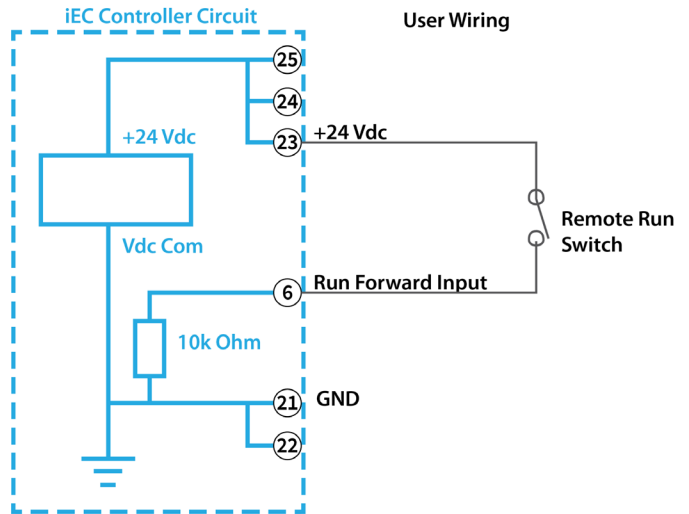

LOGIC I/O OUTPUT CONNECTION EXAMPLE

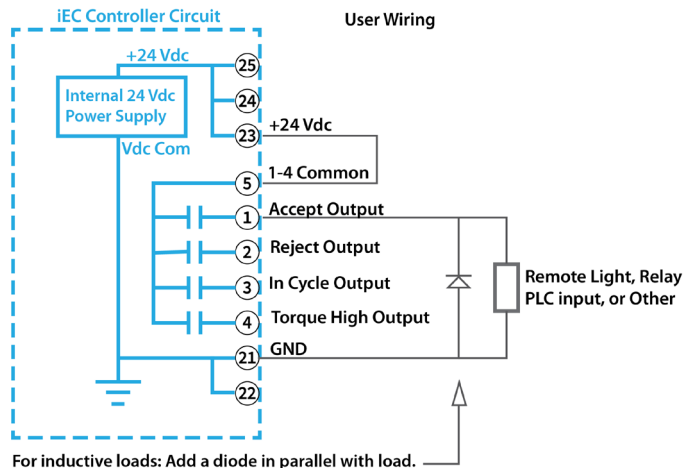

Importing I/O on an iBC Controller

These instructions detail how to import I/O into an iBC4 controller via the system port to modify the Anybus outputs.

1. Power on the controller
2. Insert the USB stick into a USB port
3. Connect to the controller via system port and web browser (default address 192.168.1.4)
4. Navigate to Advanced → Import Settings

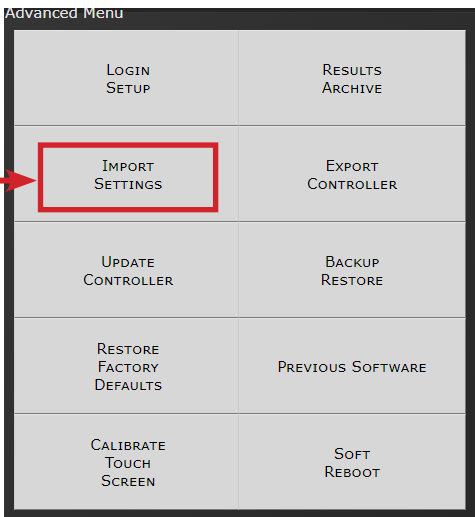

5. Choose file and select **ONLY I/O**

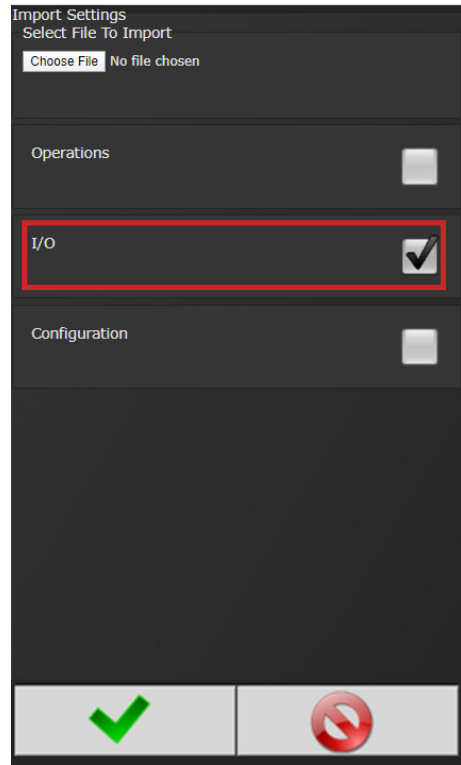

6. Click OK
7. Click OK in the Confirmation dialog box
8. The controller will restart
9. Verify the Anybus outputs.
 - a. Navigate to Controller → IO → Anybus Outputs
 - b. Click on the first row of element #1 and verify it is set as 'Running Job Number', Bit 0, Bits 8, Start at 0.
 - c. Click on element #4 and verify it is set as "Torque (x100)", Bit 0, Bits 16

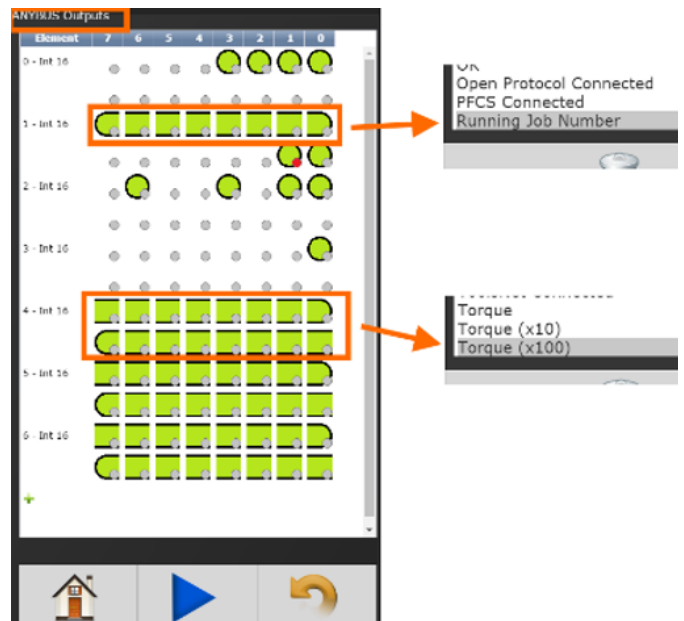

11. Assignable I/O

The Gen IV controller supports assignable I/O.

Buses: The controller is divided up into buses. Each bus has a set of inputs and a set of outputs. Currently the controller supports the following buses.

Bus Number	Bus
1	Physical I/O
2	Fieldbus (Anybus module) I/O
3	Modbus TCP
4	Ethernet/IP

All assignments have a bus, element, and bit configuration to define its location in the system. The bus value needs to be set from the list above. The element and bit define the location in the bus. The first element on the bus is 0 and goes up the last legal element for the given bus. The bits in each element is referenced from 0(LSB) to 31(MSB).

Inputs

All input assignments have a Bus, Element, and Bit configuration to define its location in the system. Along with the basic configuration many also have other configuration(s) that allow its behavior to be modified to suit the application.

	Supported Feature						Controllers				
	Bus	Element	Bit 0-31	Polarity N.O./N.C.	Width	Offset	iEC	iAC	iPC	iBC	iBC-Z
Do Nothing	√	√	√				√	√	√	√	√
Start	√	√	√	√			√				
Stop	√	√	√	√			√	√	√	√	
Reverse	√	√	√	√			√				
Disable	√	√	√	√			√	√	√		
Reset Job	√	√	√	√			√	√	√	√	√
Select PSet	√	√	√		√	√	√	√	√	√	
Select Job	√	√	√		√	√	√	√	√	√	√
Select Job Sequence	√	√	√		√	√	√	√	√	√	√
Disable Assembly	√	√	√	√			√				
Set ID	√	√	√		√		√	√	√	√	√
Set ID (word swap)	√	√	√		√		√	√	√	√	√
Set Date/Time	√	√	√		√		√	√	√	√	√
Set Date/Time (word swap)	√	√	√		√		√	√	√	√	√
Verify PSet	√	√	√		√	√	√	√	√	√	√
Clear Results	√	√	√	√			√	√	√	√	√
Log Change	√	√	√		√	√	√	√	√	√	√
Decrement Batch	√	√	√	√			√	√	√	√	√
Increment Batch	√	√	√	√			√	√	√	√	√
Click Wrench	√	√	√	√			√	√	√	√	√
Bypass Stops	√	√	√	√			√	√	√	√	√
Verify Job Sequence	√	√	√		√	√	√	√	√	√	√
ASCII ID	√	√					√	√	√	√	√
Abort Job	√	√	√	√			√	√	√	√	
Remote Start	√	√	√	√			√				
Remove Lock on Reject	√	√	√	√			√	√	√	√	
Dual Start Interlocked	√	√	√	√			√				
Decrement Job	√	√	√	√			√	√	√	√	√
Increment Job	√	√	√	√			√	√	√	√	√
Decrement PSet	√	√	√	√			√	√	√	√	√
Increment PSet	√	√	√	√			√	√	√	√	√
Decrement Job Sequence	√	√	√	√			√	√	√	√	√
Increment Job Sequence	√	√	√	√			√	√	√	√	√

Polarity

When the polarity is set to N.O. the input is considered active high (24vdc for physical inputs and logic 1 for all network type buses). When the polarity is set to N.C. the input is considered active low (0vdc for physical inputs and logic 0 for all network type buses).

Width and Offset

For multiple bit inputs (for example "Select PSet") the width variable defines the number of bits the assignment will read for its input. This allows the input size to be restricted to a few bits saving space for other assignments.

The offset variable allows a fixed value to be added to the read value.

For example to use bits 4 & 5 of the physical inputs to select parameter sets 1-4 the assignment would look like...

Select PSet		
Bus	1	For the physical bus
Element	0	For the first element on the bus
Bit	4	For the starting bit location
Width	2	To span the two bits 4 & 5
Offset	1	Adding 1 to the read input value so we get... Binary 00 = 1 Binary 01 = 2 Binary 10 = 3 Binary 11 = 4

Input Assignments

Do Nothing	Bus	Element	Bit 0-32	Polarity N.O./N.C.	Width	Offset
	√	√	√			
The "Do Nothing" assignment will run do nothing if it is active or inactive.						
Start	Bus	Element	Bit 0-32	Polarity N.O./N.C.	Width	Offset
	√	√	√	√		
The "Start" assignment will run the tool while the input is active. Start is available for the Physical I/O bus only.						
Stop	Bus	Element	Bit 0-32	Polarity N.O./N.C.	Width	Offset
	√	√	√	√		
The "Stop" assignment will stop the tool if it is running and prevent it from being started.						

Reverse	Bus	Element	Bit 0-32	Polarity N.O./N.C.	Width	Offset
	√	√	√	√		
The "Reverse" will put the controller in disassembly mode while the input is active.						
Disable	Bus	Element	Bit 0-32	Polarity N.O./N.C.	Width	Offset
	√	√	√	√		
The "Disable" will disable the tool while the input is active. It will not stop a fastening cycle that is progress.						
Reset Job	Bus	Element	Bit 0-32	Polarity N.O./N.C.	Width	Offset
	√	√	√	√		
On the transition of inactive to active the "Reset Job" assignment will reset the active job.						
Select PSet	Bus	Element	Bit 0-32	Polarity N.O./N.C.	Width	Offset
	√	√	√		√	√
The "Select PSET" input will select the parameter set according to the input value. Uses the width parameter limit the width of the input bits read. The minimum width is 1 and the maximum is 8. After the input is read the offset parameter will be added to the value do get the actual parameter set number. Selecting an invalid parameter set number will disable the tool.						
Select Job	Bus	Element	Bit 0-32	Polarity N.O./N.C.	Width	Offset
	√	√	√		√	√
The "Select Job" input will select the job number according to the input value. Uses the width parameter limit the width of the input bits read. The minimum width is 1 and the maximum is 8. After the input is read the offset parameter will be added to the value do get the actual job number. Selecting an invalid job number will disable the tool.						
Select Job Sequence	Bus	Element	Bit 0-32	Polarity N.O./N.C.	Width	Offset
	√	√	√		√	√
The "Select Job Sequence" input will select the job sequence number according to the input value. Uses the width parameter limit the width of the input bits read. The minimum width is 1 and the maximum is 8. After the input is read the offset parameter will be added to the value do get the actual job sequence number. Selecting an invalid job sequence number or a sequence that is already complete will disable the tool.						

Disable Assembly	Bus	Element	Bit 0-32	Polarity N.O./N.C.	Width	Offset
	√	√	√	√		

The "Disable Assembly" assignment will disable the tool in the assembly direction. It will not disable the tool in disassembly or tube nut homing. It will not stop a fastening cycle that is progress.

Set ID	Bus	Element	Bit 0-32	Polarity N.O./N.C.	Width	Offset
	√	√	√		√	

The "Set ID" assignment will set the ID to an integer value of the input value. The width can be set from 1 to 32 bits. The input value will read as an integer value and an ASCII string with leading zeros will be produced and passed to the ID recognition system. The length of the string is based on the width of the assignment. The string will always be sized to accommodate the maximum value of the input. For example a width setting of 16 can have an integer value of 0-65535 so the produced ID would be "00000" to "65535" (always five character long).

Width setting	Length of ID string	ID value
1 - 3	1	"0" - "n"
4 - 6	2	"00" - "nn"
7 - 9	3	"000" - "nnn"
10 - 13	4	"0000" - "nnnn"
14 - 16	5	"00000" - "nnnnn"
17 - 19	6	"000000" - "nnnnnn"
20 - 23	7	"0000000" - "nnnnnnn"
24 - 26	8	"00000000" - "nnnnnnnn"
27 - 29	9	"000000000" - "nnnnnnnnn"
30 - 32	10	"0000000000" - "nnnnnnnnnn"

Set ID (word swap)	Bus	Element	Bit 0-32	Polarity N.O./N.C.	Width	Offset
	√	√	√		√	

The "Set ID (word swap)" assignment is the same as the "Set ID" assignment except the high and low words (16bit) are swapped prior to evaluation. This is to correct the mixed endianness of some PLC. See the "Set ID" for behavior.

Set Date/Time	Bus	Element	Bit 0-32	Polarity N.O./N.C.	Width	Offset
	√	√	√		√	

The "Set Date/Time" assignment will set the date and time of the controller. The width can be set from 1 to 32 bits but should always be set to 32 to get the correct results. The input value will be read as the number of seconds since 00:00:00 January 1, 1970 (POSIX time or Epoch time). If the input value changes and it is non-zero the date and time of the controller will be set to the new value.

Set Date/Time (word swap)	Bus	Element	Bit 0-32	Polarity N.O./N.C.	Width	Offset
	√	√	√		√	

The "Set Date/Time (word swap)" assignment is the same as the "Set Date/Time" assignment except the high and low words (16bit) are swapped prior to evaluation. This is to correct the mixed endianness of some PLC. See the "Set Date/Time" for behavior.

Verify PSet	Bus	Element	Bit 0-32	Polarity N.O./N.C.	Width	Offset
	√	√	√		√	√

The "Verify PSET" input will compare the current parameter set to the input value. Uses the width parameter limit the width of the input bits read. The minimum width is 1 and the maximum is 8. After the input is read the offset parameter will be added to the value do get the actual parameter set number. If the parameter set input value does not match the current parameter of the controller the tool will be disabled.

Clear Results	Bus	Element	Bit 0-32	Polarity N.O./N.C.	Width	Offset
	√	√	√	√		

The "Clear Results" assignment will clear the latest results outputs (Ok, Nok, etc.) on the same bus.

Log Change	Bus	Element	Bit 0-32	Polarity N.O./N.C.	Width	Offset
	√	√	√		√	√

The "Log Change" assignment will add entries to the controller event log when the input changes.

Decrement Batch	Bus	Element	Bit 0-32	Polarity N.O./N.C.	Width	Offset
	√	√	√	√		

The "Decrement Batch" assignment will remove the latest OK rundown from the current running JOB. This will cause the JOB count to be reduced by one.

Increment Batch	Bus	Element	Bit 0-32	Polarity N.O./N.C.	Width	Offset
	√	√	√	√		

The "Increment Batch" assignment will insert a manual rundown into the current sequence of the current JOB. This will cause the JOB count to increment by one.

Click Wrench	Bus	Element	Bit 0-32	Polarity N.O./N.C.	Width	Offset
	√	√	√	√		

The "Click Wrench" assignment is the same as "Increment Batch" with the addition of a programmable torque value.

Bypass Stops	Bus	Element	Bit 0-32	Polarity N.O./N.C.	Width	Offset
	√	√	√	√		

The "Bypass Stops" assignment removes most stop conditions, allowing the tool to be ran in an override type condition. Hardware faults, stop and disable inputs are not removed.

Verify Job Sequence	Bus	Element	Bit 0-32	Polarity N.O./N.C.	Width	Offset
	√	√	√		√	√

The "Verify Job Sequence" input will compare the current Job sequence to the input value. Uses the width parameter limit the width of the input bits read. The minimum width is 1 and the maximum is 8. After the input is read the offset parameter will be added to the value do get the actual Job sequence number. If the Job sequence input value does not match the current Job sequence of the controller the tool will be disabled.

ASCII ID	Bus	Element	Bit 0-32	Polarity N.O./N.C.	Width	Offset
	√	√				

The "ASCII ID" assignment will set the ID to the of the input (ASCII) value. This assignment consumes the entire element so the Bit is not used. It also has a length parameter to set the length of the input in bytes. The input value will be passed directly to the ID recognition system.

Abort Job	Bus	Element	Bit 0-32	Polarity N.O./N.C.	Width	Offset
	√	√	√	√		

The "Abort Job" assignment aborts the job and disables the tool. A job reset is required to enable the tool for the next job.

Remote Start	Bus	Element	Bit 0-32	Polarity N.O./N.C.	Width	Offset
	√	√	√	√		

The "Remote Start" assignment will run the tool while the input is active. Remote Start is available for non-physical I/O buses.

Remove Lock on Reject	Bus	Element	Bit 0-32	Polarity N.O./N.C.	Width	Offset
	√	√	√	√		

The "Remove Lock on Reject" assignment unlocks the tool if locked on reject, re-enabling the tool.

Dual Start Interlocked	Bus	Element	Bit 0-32	Polarity N.O./N.C.	Width	Offset
	√	√	√	√		

The "Dual Start Interlocked" assignment will run the tool if the interlock conditions are met. Dual Start Interlock is available for the Physical IO bus only. The Dual Start Interlocked input works in combination with the Physical input assigned to the 'Start' input. The Dual Start Interlocked is only available for iEC controllers.

Setup

- Only 1 Start Input and 1 Dual Start Interlocked Input should be assigned.
- Controller->Tool Setup -> Start Input Configuration:
 - The Start Input Source Must be set to 'Start From IO'.
 - Latching throttle is disabled for Dual Interlocked Start.

Dual Start Interlocked - Operation

- The tool will not run unless both inputs are activated within two seconds of each other.
- If the two second timer times out, both inputs must be deactivated to reset the timer.
- If either input is deactivated the tool stops.
- To restart the tool, both inputs must be deactivated then reactivated within two seconds of each other.

Tubenut Tool Homing Exceptions for Dual Start Interlocked functionality

- If controller's tubenut homing configuration is set to RELEASE:
 - Deactivating either, or both, of the inputs will initiate the homing sequence.
 - Homing will continue until sequence is complete.
- If controller's tubenut homing configuration is set to RELEASE AND REPRESS:
 - Deactivating either of the inputs, then activating both inputs will initiate the homing sequence.
 - Homing will continue while both inputs are active.
 - If either input is deactivated, before homing is complete, the tool will stop, and homing will pause until both inputs are reactivated.
 - To restart tool, after homing is complete, both inputs must be deactivated, then reactivated within two seconds of each other.

Decrement Job	Bus	Element	Bit 0-32	Polarity N.O./N.C.	Width	Offset
	√	√	√	√		

The “Decrement Job” assignment will decrement the Job Number, selecting the last job if decrementing past the first one.

Increment Job	Bus	Element	Bit 0-32	Polarity N.O./N.C.	Width	Offset
	√	√	√	√		

The “Increment Job” assignment will increment the Job Number, selecting the first job if incrementing past the last one.

Decrement PSet	Bus	Element	Bit 0-32	Polarity N.O./N.C.	Width	Offset
	√	√	√	√		

The “Decrement PSet” assignment will decrement the PSet Number, selecting the last PSet if decrementing past the first one.

Increment PSet	Bus	Element	Bit 0-32	Polarity N.O./N.C.	Width	Offset
	√	√	√	√		

The “Increment PSet” assignment will increment the PSet Number, selecting the first PSet if incrementing past the last one.

Decrement Job Sequence	Bus	Element	Bit 0-32	Polarity N.O./N.C.	Width	Offset
	√	√	√	√		

The “Decrement Job Sequence” assignment will decrement the Job sequence, selecting the last job sequence if decrementing past the first one.

Increment Job Sequence	Bus	Element	Bit 0-32	Polarity N.O./N.C.	Width	Offset
	√	√	√	√		

The “Increment Job Sequence” assignment will increment the Job sequence, selecting the first job if incrementing past the last one.

AcraDyne Gen IV iBC-Z Controller Manual

Outputs

All output assignments have a Bus, Element, and Bit configuration to define its location in the system. Along with the basic configuration many also have other configuration(s) that allow its behavior to be modified to suit the application.

	Supported Feature											Controller				
	Bus	Element	Bit 0-32	Polarity N.O./ N.C.	Mode Normal, Timed, Flashed	Time	Width	Offset	Input Bus	Input Element	Input Bit	iEC	iAC	iPC	iBC	iBC-Z
Ok	√	√	√	√	√							√	√	√	√	√
Nok	√	√	√	√	√							√	√	√	√	√
Torque Ok	√	√	√	√	√							√	√	√	√	√
Torque Nok	√	√	√	√	√							√	√	√	√	√
Low Torque	√	√	√	√	√							√	√	√	√	√
High Torque	√	√	√	√	√							√	√	√	√	√
Angle Ok	√	√	√	√	√							√	√	√	√	√
Angle Nok	√	√	√	√	√							√	√	√	√	√
Low Angle	√	√	√	√	√							√	√	√	√	√
High Angle	√	√	√	√	√							√	√	√	√	√
Fastening Complete	√	√	√	√	√							√	√	√	√	√
In Cycle	√	√	√	√	√							√	√	√		
Fastening Aborted	√	√	√	√	√							√	√	√	√	√
Fastening Stopped	√	√	√	√	√							√	√	√	√	√
Batch Complete	√	√	√	√	√							√	√	√	√	√
Job Complete	√	√	√	√	√							√	√	√	√	√
Error	√	√	√	√	√							√	√	√	√	√
Tool Start Switch	√	√	√	√	√							√				
Tool Push to Start Switch	√	√	√	√	√							√				
Tool MFB	√	√	√	√	√							√				
Tool Enabled	√	√	√	√	√							√	√	√	√	√
Tool Running	√	√	√	√	√							√				
Service Indicator	√	√	√	√	√							√	√	√		√
ToolsNet Connected	√	√	√	√	√							√	√	√	√	√
Open Protocol Connected	√	√	√	√	√							√	√	√	√	√
PFCs Connected	√	√	√	√	√							√	√	√	√	√
Running PSet Number	√	√	√				√	√				√	√	√	√	√
Running Job Number	√	√	√				√	√				√	√	√	√	√
External Controlled	√	√	√						√	√	√	√	√	√	√	√
Tool In CCW	√	√	√	√	√							√				
Tool In CW	√	√	√	√	√							√				
Torque	√	√	√				√					√	√	√	√	√
Torque (x10)	√	√	√				√					√	√	√	√	√
Torque (x100)	√	√	√				√					√	√	√	√	√
Angle	√	√	√				√					√	√	√	√	√
Rundown Saved to FTP Server	√	√	√				√					√	√	√	√	√
Fastener Removed	√	√	√	√	√							√	√	√		
Spindle Ok	√	√	√	√	√							√				
Spindle NOK	√	√	√	√	√							√				
Spindle Fastening Complete	√	√	√	√	√							√				
Pulses	√	√	√				√						√	√		√
Pulses High	√	√	√	√	√								√	√		√
Pulses Low	√	√	√	√	√								√	√		√
Pulses NOK	√	√	√	√	√								√	√		√
Pulses Ok	√	√	√	√	√								√	√		√
ON	√	√	√	√	√							√	√	√	√	√
Job Aborted	√	√	√	√	√							√	√	√	√	
Tool In Use	√	√	√	√		√						√	√	√	√	√
Barcode Scanned	√	√	√	√								√	√	√	√	√
Start Trigger Active	√	√	√	√								√				

Polarity

When the polarity is set to N.O. the output will be high when it is active (24vdc for physical outputs and logic 1 for all network type buses). When the polarity is set to N.C. the output will be low for active (0vdc for physical inputs and logic 0 for all network type buses).

Mode

Normal

In the "Normal" mode the output will track the state of the assignment (while still observing the polarity setting). If the polarity is set N.O. and the assignment has an active output the output will be on and stay on till the assignment goes to inactive.

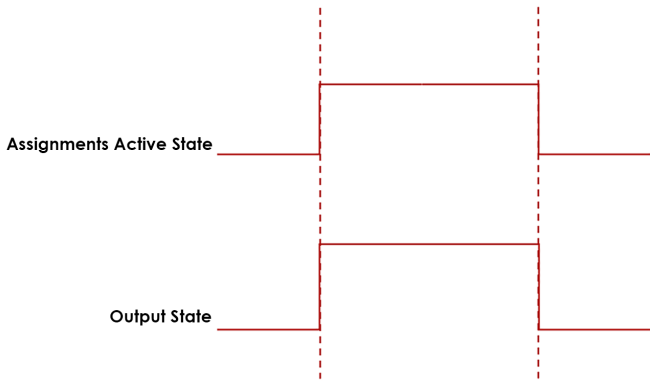

Figure 1: Normal Mode

Timed

In the "Timed" mode the output will come on when the assignments state goes active and go off based on the time value or the assignment state going inactive (while still observing the polarity setting).

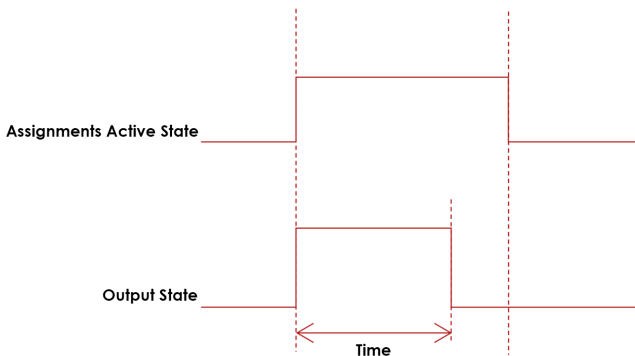

Figure 2 Timed Mode

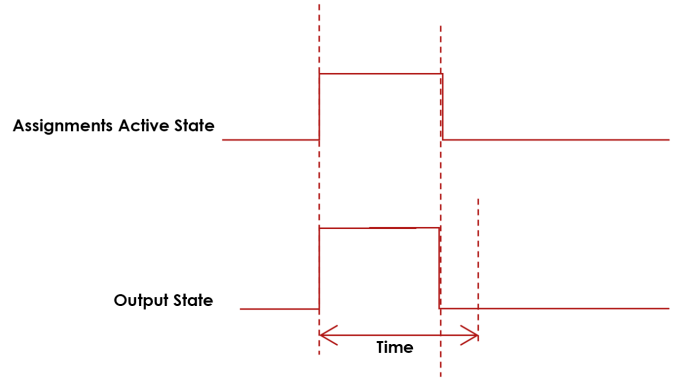

Figure 3: Timed Mode (assignment deactivates before time expires)

Flash

In the "flash" mode the output will flash at the time rate while the assignments state is active (while still observing the polarity setting).

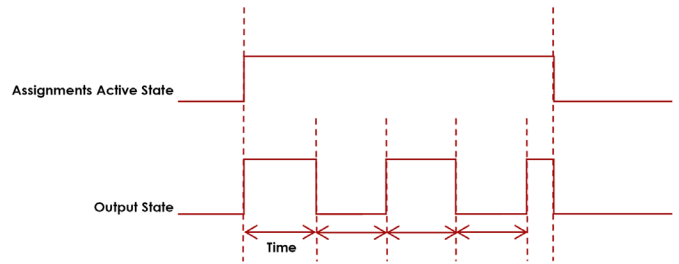

Figure 3 Flash Mode

Width and Offset

For multiple bit outputs (for example "Running PSet Number") the width variable defines the number of bits the assignment will output. This allows the output size to be restricted to a few bits saving space for other assignments.

The offset variable allows a fixed value to be added to the value before it is output.

For example to use bits 4 & 5 of the physical outputs to indicate the selected parameter set number 1-4 as binary 0-3 the assignment would look like...

Running PSet Number		
Bus	1	For the physical bus
Element	0	For the first element on the bus
Bit	4	For the starting bit location
Width	2	To span the two bits 4 & 5
Offset	-1	Adding -1 to the read input value so we get... 1 = Binary 00 2 = Binary 01 3 = Binary 10 4 = Binary 11

Output Assignments

	Bus	Element	Bit 0-32	Polarity N.O./N.C.	Mode: Normal, Timed, Flash	Time	Width	Offset	Input Bus	Input Element	Input Bit
OK	√	√	√	√	√						
<p>The “Ok” output assignment will go active at the completion of an acceptable fastening. It will go inactive when the next fastening is started (the torque exceeds the threshold value) or a Job reset.</p>											
Nok	√	√	√	√	√						
<p>The “Nok” output assignment will go active at the completion of an unacceptable fastening. It will go inactive when the next fastening is started (the torque exceeds the threshold value) or a Job reset.</p>											
Torque Ok	√	√	√	√	√						
<p>The “Torque Ok” output assignment will go active at the completion of a fastening that has an acceptable torque value. It will go inactive when the next fastening is started (the torque exceeds the threshold value) or a Job reset.</p>											
Torque Nok	√	√	√	√	√						
<p>The “Torque Nok” output assignment will go active at the completion of a fastening that has an unacceptable torque value. It will go inactive when the next fastening is started (the torque exceeds the threshold value) or a Job reset.</p>											
Low Torque	√	√	√	√	√						
<p>The “Low Torque” output assignment will go active at the completion of a fastening that has a low torque results. It will go inactive when the next fastening is started (the torque exceeds the threshold value) or a Job reset.</p>											
High Torque	√	√	√	√	√						
<p>The “High Torque” output assignment will go active at the completion of a fastening that has a high torque results. It will go inactive when the next fastening is started (the torque exceeds the threshold value) or a Job reset.</p>											
Angle Ok	√	√	√	√	√						
<p>The “Angle Ok” output assignment will go active at the completion of a fastening that has an acceptable angle results. It will go inactive when the next fastening is started (the torque exceeds the threshold value) or a Job reset.</p>											
Angle Nok	√	√	√	√	√						
<p>The “Angle Nok” output assignment will go active at the completion of a fastening that has an unacceptable angle results. It will go inactive when the next fastening is started (the torque exceeds the threshold value) or a Job reset.</p>											
Low Angle	√	√	√	√	√						
<p>The “Low Angle” output assignment will go active at the completion of a fastening that has a low angle results. It will go inactive when the next fastening is started (the torque exceeds the threshold value) or a Job reset.</p>											
High Angle	√	√	√	√	√						
<p>The “High Angle” output assignment will go active at the completion of a fastening that has high angle results. It will go inactive when the next fastening is started (the torque exceeds the threshold value) or a Job reset.</p>											

Fastening Complete	Bus	Element	Bit 0-32	Polarity N.O./N.C.	Mode: Normal, Timed, Flash	Time	Width	Offset	Input Bus	Input Element	Input Bit
	√	√	√	√	√						

The “Fastening Complete” output assignment will go active at the completion of a fastening. It will go inactive when the next fastening is started (the torque exceeds the threshold value) or a Job reset.

In Cycle	Bus	Element	Bit 0-32	Polarity N.O./N.C.	Mode: Normal, Timed, Flash	Time	Width	Offset	Input Bus	Input Element	Input Bit
	√	√	√	√	√						

The “In Cycle” output assignment will go active at the start of the fastening cycle (the torque exceeds the threshold value). It will go inactive when the fastening cycle ends.

Fastening Aborted	Bus	Element	Bit 0-32	Polarity N.O./N.C.	Mode: Normal, Timed, Flash	Time	Width	Offset	Input Bus	Input Element	Input Bit
	√	√	√	√	√						

The “Fastening Aborted” output assignment will go active at the completion of a fastening that was aborted by the system. It will go inactive when the next fastening is started (the torque exceeds the threshold value) or a Job reset.

Fastening Stopped	Bus	Element	Bit 0-32	Polarity N.O./N.C.	Mode: Normal, Timed, Flash	Time	Width	Offset	Input Bus	Input Element	Input Bit
	√	√	√	√	√						

The “Fastening Stopped” output assignment will go active at the completion of a fastening that was stopped by the user. It will go inactive when the next fastening is started (the torque exceeds the threshold value) or a Job reset.

Batch Complete	Bus	Element	Bit 0-32	Polarity N.O./N.C.	Mode: Normal, Timed, Flash	Time	Width	Offset	Input Bus	Input Element	Input Bit
	√	√	√	√	√						

The “Batch Complete” output assignment will go active at the completion of a fastening that satisfies the bolt count of a Job sequence. It will go inactive when the next fastening is started (the torque exceeds the threshold value) or the job is reset.

Job Complete	Bus	Element	Bit 0-32	Polarity N.O./N.C.	Mode: Normal, Timed, Flash	Time	Width	Offset	Input Bus	Input Element	Input Bit
	√	√	√	√	√						

The “Job Complete” output assignment will go active at the completion of a fastening that satisfies all the sequences. It will go inactive when the next fastening is started (the torque exceeds the threshold value) or the job is reset.

Error	Bus	Element	Bit 0-32	Polarity N.O./N.C.	Mode: Normal, Timed, Flash	Time	Width	Offset	Input Bus	Input Element	Input Bit
	√	√	√	√	√						

The “Error” output assignment will be active while the controller has an error.

Tool Start Switch	Bus	Element	Bit 0-32	Polarity N.O./N.C.	Mode: Normal, Timed, Flash	Time	Width	Offset	Input Bus	Input Element	Input Bit
	√	√	√	√	√						

The “Tool Start Switch” output assignment will reflect the state of the tools start lever.

Tool Push to Start Switch	Bus	Element	Bit 0-32	Polarity N.O./N.C.	Mode: Normal, Timed, Flash	Time	Width	Offset	Input Bus	Input Element	Input Bit
	√	√	√	√	√						

The “Tool Push to Start Switch” output assignment will reflect the state of the tools push to start switch.

Tool MFB	Bus	Element	Bit 0-32	Polarity N.O./N.C.	Mode: Normal, Timed, Flash	Time	Width	Offset	Input Bus	Input Element	Input Bit
	√	√	√	√	√						

The “Tool MFB” output assignment will reflect the state of the tools multifunction button.

Tool Enabled	Bus	Element	Bit 0-32	Polarity N.O./N.C.	Mode: Normal, Timed, Flash	Time	Width	Offset	Input Bus	Input Element	Input Bit
	√	√	√	√	√						

The “Tool Enabled” output assignment will be active if the tool is enabled.

Tool Running	Bus	Element	Bit 0-32	Polarity N.O./N.C.	Mode: Normal, Timed, Flash	Time	Width	Offset	Input Bus	Input Element	Input Bit
	√	√	√	√	√						

The "Tool Running" output assignment will be active while the tool is running.

Service Indicator	Bus	Element	Bit 0-32	Polarity N.O./N.C.	Mode: Normal, Timed, Flash	Time	Width	Offset	Input Bus	Input Element	Input Bit
	√	√	√	√	√						

The "Service Indicator" output assignment will be active if the system is in need of service.

ToolsNet Connected	Bus	Element	Bit 0-32	Polarity N.O./N.C.	Mode: Normal, Timed, Flash	Time	Width	Offset	Input Bus	Input Element	Input Bit
	√	√	√	√	√						

The "ToolsNet Connected" output assignment will be active if the controller has an active connection to a ToolsNet server.

Open Protocol Connected	Bus	Element	Bit 0-32	Polarity N.O./N.C.	Mode: Normal, Timed, Flash	Time	Width	Offset	Input Bus	Input Element	Input Bit
	√	√	√	√	√						

The "Open Protocol Connected" output assignment will be active if the controller has an active Open protocol connection.

PFCS Connected	Bus	Element	Bit 0-32	Polarity N.O./N.C.	Mode: Normal, Timed, Flash	Time	Width	Offset	Input Bus	Input Element	Input Bit
	√	√	√	√	√						

The "PFCS Connected" output assignment will be active if the controller has an active PFCS connection.

Running PSet Number	Bus	Element	Bit 0-32	Polarity N.O./N.C.	Mode: Normal, Timed, Flash	Time	Width	Offset	Input Bus	Input Element	Input Bit
	√	√	√				√	√			

The "Running PSet Number" output assignment will output the current PSet number.

Running Job Number	Bus	Element	Bit 0-32	Polarity N.O./N.C.	Mode: Normal, Timed, Flash	Time	Width	Offset	Input Bus	Input Element	Input Bit
	√	√	√				√	√			

The "Running Job Number" output assignment will output the current Job number.

External Controlled	Bus	Element	Bit 0-32	Polarity N.O./N.C.	Mode: Normal, Timed, Flash	Time	Width	Offset	Input Bus	Input Element	Input Bit
	√	√	√						√	√	√

The "External Controlled" output assignment will reflect the state of an input. Use the "Input Bus", "Input Element", and "Input Bit" to specify the input to reflect.

Tool in CCW	Bus	Element	Bit 0-32	Polarity N.O./N.C.	Mode: Normal, Timed, Flash	Time	Width	Offset	Input Bus	Input Element	Input Bit
	√	√	√	√	√						

The "Tool In CCW" output assignment will be active if the tool is put into disassembly mode and inactive if the tool is in assembly mode.

Tool in CW	Bus	Element	Bit 0-32	Polarity N.O./N.C.	Mode: Normal, Timed, Flash	Time	Width	Offset	Input Bus	Input Element	Input Bit
	√	√	√	√	√						

The "Tool In CW" output assignment will be active when the is in assembly mode and inactive if the tool is put into disassembly mode.

Torque	Bus	Element	Bit 0-32	Polarity N.O./N.C.	Mode: Normal, Timed, Flash	Time	Width	Offset	Input Bus	Input Element	Input Bit
	√	√	√				√				

The "Torque" output assignment will output the final torque value of the most recent rundown. The value will be cleared to 0 at the start of a new fastening cycle or a Job reset. At the end of the fastening cycle the final torque will be truncated to an integer and output.

AcraDyne Gen IV iBC-Z Controller Manual

Torque (x10)	Bus	Element	Bit 0-32	Polarity N.O./N.C.	Mode: Normal, Timed, Flash	Time	Width	Offset	Input Bus	Input Element	Input Bit
	√	√	√				√				
<p>The “Torque (x10)” output assignment will output the final torque value of the most recent rundown. The value will be cleared to 0 at the start of a new fastening cycle or a Job reset. At the end of the fastening cycle the final torque will be multiplied by 10, truncated to an integer and output.</p>											
Torque (x100)	Bus	Element	Bit 0-32	Polarity N.O./N.C.	Mode: Normal, Timed, Flash	Time	Width	Offset	Input Bus	Input Element	Input Bit
	√	√	√				√				
<p>The “Torque (x100)” output assignment will output the final torque value of the most recent rundown. The value will be cleared to 0 at the start of a new fastening cycle or a Job reset. At the end of the fastening cycle the final torque will be multiplied by 100, truncated to an integer and output.</p>											
Angle	Bus	Element	Bit 0-32	Polarity N.O./N.C.	Mode: Normal, Timed, Flash	Time	Width	Offset	Input Bus	Input Element	Input Bit
	√	√	√				√				
<p>The “Angle” output assignment will output the final angle value of the most recent rundown. The value will be cleared to 0 at the start of a new fastening cycle or a Job reset.</p>											
Rundown Saved to FTP Server	Bus	Element	Bit 0-32	Polarity N.O./N.C.	Mode: Normal, Timed, Flash	Time	Width	Offset	Input Bus	Input Element	Input Bit
	√	√	√				√				
<p>The “Rundown Saved to FTP Server” output assignment will output the ID of the last rundown that was saved to the FTP server.</p>											
Fastener Removed	Bus	Element	Bit 0-32	Polarity N.O./N.C.	Mode: Normal, Timed, Flash	Time	Width	Offset	Input Bus	Input Element	Input Bit
	√	√	√	√	√						
<p>The “Fastener Removed” output assignment will go active when a fastener is removed by the operator. The controller must be configured to report disassembly for this output to work. It will go inactive when the next fastening is started (the torque exceeds the threshold value) or a Job reset.</p>											
Spindle OK	Bus	Element	Bit 0-32	Polarity N.O./N.C.	Mode: Normal, Timed, Flash	Time	Width	Offset	Input Bus	Input Element	Input Bit
	√	√	√	√	√						
<p>The “Spindle Ok” output assignment will go active at the completion of multi-spindle fastening if all spindles have an OK. It will go inactive when the next fastening is started (the torque exceeds the threshold value) or a Job reset.</p>											
Spindle NOk	Bus	Element	Bit 0-32	Polarity N.O./N.C.	Mode: Normal, Timed, Flash	Time	Width	Offset	Input Bus	Input Element	Input Bit
	√	√	√	√	√						
<p>The “Spindle NOK” output assignment will go active at the completion of multi-spindle fastening if one or more of the spindles have an NOK. It will go inactive when the next fastening is started (the torque exceeds the threshold value) or a Job reset.</p>											
Spindle Fastening Complete	Bus	Element	Bit 0-32	Polarity N.O./N.C.	Mode: Normal, Timed, Flash	Time	Width	Offset	Input Bus	Input Element	Input Bit
	√	√	√	√	√						
<p>The “Spindle Fastening Complete” output assignment will go active at the completion of multi-spindle fastening. It will go inactive when the next fastening is started (the torque exceeds the threshold value) or a Job reset.</p>											
Pulses	Bus	Element	Bit 0-32	Polarity N.O./N.C.	Mode: Normal, Timed, Flash	Time	Width	Offset	Input Bus	Input Element	Input Bit
	√	√	√				√				
<p>The “Pulses” output assignment will output the pulse count value of the most recent rundown. The value will be cleared to 0 at the start of a new fastening cycle or a Job reset.</p>											
Pulses High	Bus	Element	Bit 0-32	Polarity N.O./N.C.	Mode: Normal, Timed, Flash	Time	Width	Offset	Input Bus	Input Element	Input Bit
	√	√	√	√	√						
<p>The “Pulses High” output assignment will go active at the completion of a fastening that has a pulse count that exceeds the high limit. It will go inactive when the next fastening is started (the torque exceeds the threshold value) or a Job reset.</p>											

Pulses Low	Bus	Element	Bit 0-32	Polarity N.O./N.C.	Mode: Normal, Timed, Flash	Time	Width	Offset	Input Bus	Input Element	Input Bit
	√	√	√	√	√						
<p>The "Pulses Low" output assignment will go active at the completion of a fastening that has an pulse count that falls below the low limit. It will go inactive when the next fastening is started (the torque exceeds the threshold value) or a Job reset.</p>											
Pulses NOK	Bus	Element	Bit 0-32	Polarity N.O./N.C.	Mode: Normal, Timed, Flash	Time	Width	Offset	Input Bus	Input Element	Input Bit
	√	√	√	√	√						
<p>The "Pulses Ok" output assignment will go active at the completion of a fastening that has an acceptable pulse count. It will go inactive when the next fastening is started (the torque exceeds the threshold value) or a Job reset.</p>											
Pulses Ok	Bus	Element	Bit 0-32	Polarity N.O./N.C.	Mode: Normal, Timed, Flash	Time	Width	Offset	Input Bus	Input Element	Input Bit
	√	√	√	√	√						
<p>The "Pulses NOK" output assignment will go active at the completion of a fastening that has an unacceptable pulse count. It will go inactive when the next fastening is started (the torque exceeds the threshold value) or a Job reset.</p>											
ON	Bus	Element	Bit 0-32	Polarity N.O./N.C.	Mode: Normal, Timed, Flash	Time	Width	Offset	Input Bus	Input Element	Input Bit
	√	√	√	√	√						
<p>The "ON" output assignment will be active when the controller is powered up and remains active until power down.</p>											
Job Aborted	Bus	Element	Bit 0-32	Polarity N.O./N.C.	Mode: Normal, Timed, Flash	Time	Width	Offset	Input Bus	Input Element	Input Bit
	√	√	√	√	√						
<p>The "Job Aborted" output assignment will go active if a Job is aborted. It will go inactive when the job is reset.</p>											
Tool In Use	Bus	Element	Bit 0-32	Polarity N.O./N.C.	Mode: Normal, Timed, Flash	Time	Width	Offset	Input Bus	Input Element	Input Bit
	√	√	√	√		√					
<p>The "Tool In Use" output assignment will go active when the trigger is pressed, whereupon a timer will restart. It will go inactive when the specified time is reached without becoming active in between.</p>											
Barcode Scanned	Bus	Element	Bit 0-32	Polarity N.O./N.C.	Mode: Normal, Timed, Flash	Time	Width	Offset	Input Bus	Input Element	Input Bit
	√	√	√	√							
<p>The "Barcode Scanned" output assignment will go active when a barcode is scanned. The ID # (1-4) will activate the corresponding bit, if it is covered by the number of bits configured. The maximum size is 4 bits. All bits will go inactive when a tool reaches the InCycle threshold of a rundown or when they are reset.</p>											
Start Trigger Active	Bus	Element	Bit 0-32	Polarity N.O./N.C.	Mode: Normal, Timed, Flash	Time	Width	Offset	Input Bus	Input Element	Input Bit
	√	√	√	√							
<p>The 'Start Trigger Active' assignment will reflect the state of the active Start Input configured to run the tool.</p>											

Possible Start Inputs include:

- Start from IO
 - Start
 - Dual Start Interlocked
- Start from Tool Buttons
 - Lever and/or PTS
 - Dual Levers Interlocked
 - Start from Master Tool
 - Start from Remote Start
 - Latched Throttle

Start Trigger Active is available for the iEC Controller Only.

12. Controller Supported MIDs

Supported MID			
MID	Description	Revisions	Note
1	Communication start	1,2,3	
2	Communication start acknowledge	1,2,3	
3	Communication stop		
4	Command error		
5	Command accepted		
8	Application data subscribe		Support MID 900 curve data only
9	Application data unsubscribe		Support MID 900 curve data only
10	Parameter set ID upload request		
11	Parameter set ID upload reply		
12	Parameter set data upload request		
13	Parameter set data upload reply		Always returns a batch size of 0
14	Parameter set selected subscribe		
15	Parameter set selected		
16	Parameter set selected acknowledge		
17	Parameter set selected unsubscribe		
18	Select Parameter set		
19	Set Parameter set batch size		
20	Reset Parameter set batch counter		
30	Job ID upload request		
31	Job ID upload reply		
34	Job info subscribe		
35	Job info		
36	Job info acknowledge		
37	Job info unsubscribe		
38	Select Job		
39	Job restart		
40	Tool data upload request	1,2	
41	Tool data upload reply		
42	Disable tool		
43	Enable tool		
50	Vehicle ID number download request		
51	Vehicle ID number subscribe	1,2	
52	Vehicle ID number	1,2	Has an option to send w/without IDs
53	Vehicle ID number acknowledge		
54	Vehicle ID number unsubscribe		
60	Last tightening result data subscribe	1-6,999	
61	Last tightening result data		
62	Last tightening result data acknowledge		
63	Last tightening result data unsubscribe		
64	Old tightening result upload request		

Supported MID			
MID	Description	Revisions	Note
65	Old tightening result upload reply		
70	Alarm subscribe		
71	Alarm		
72	Alarm acknowledge		
73	Alarm unsubscribe		
76	Alarm status		
77	Alarm status acknowledge		
80	Read time upload request		
81	Read time upload reply		
82	Set time		
90	Multi spindle status subscribe		
91	Multi spindle status		
92	Multi spindle status acknowledge		
93	Multi spindle status unsubscribe		
100	Multi spindle results subscribe		
101	Multi spindle results		
102	Multi spindle results acknowledge		
103	Multi spindle results unsubscribe		
113	Flash green light on tool		
127	Abort Job		
128	Job batch increment		
129	Job batch decrement		
130	Job off		
150	Identifier download request		
157	Reset all Identifiers		
200	Set external controlled relays		Only supports 0 (off) and 1 (on)
210	Status external monitored inputs subscribe		
211	Status external monitored inputs		
212	Status external monitored inputs acknowledge		
213	Status external monitored inputs unsubscribe		
214	IO device status request	1,2	
215	IO device status reply		
216	Relay function subscribe		See supported relay functions below.
217	Relay function		
218	Relay function acknowledge		
219	Relay function unsubscribe		
241	User data subscribe		Out_1 - Pulse status (0= OK, 1 = Low, 2 = High)
242	User data		
243	User data acknowledge		
244	Relay function unsubscribe		Out_2 - Pulses Out_3 - Undefined Out_4 - Undefined
900	Trace data		Trace type 1 & 2 only (angle & torque)
9999	Keep alive open protocol communication		

Supported Relay Functions

Supported Relay Functions Number	Function
1	OK
2	NOK
5	Low Torque
6	High Torque
7	Low angle
8	High angle

Supported Relay Functions Number	Function
9	Cycle complete
10	Alarm
11	Batch NxOK
12	Job OK
19	Tool ready
20	Tool start switch

Supported Relay Functions Number	Function
21	Dir. switch = CW
22	Dir. switch = CCW
26	Tool running
145	Start Trigger Active
276	Cycle abort

13. Dimensions

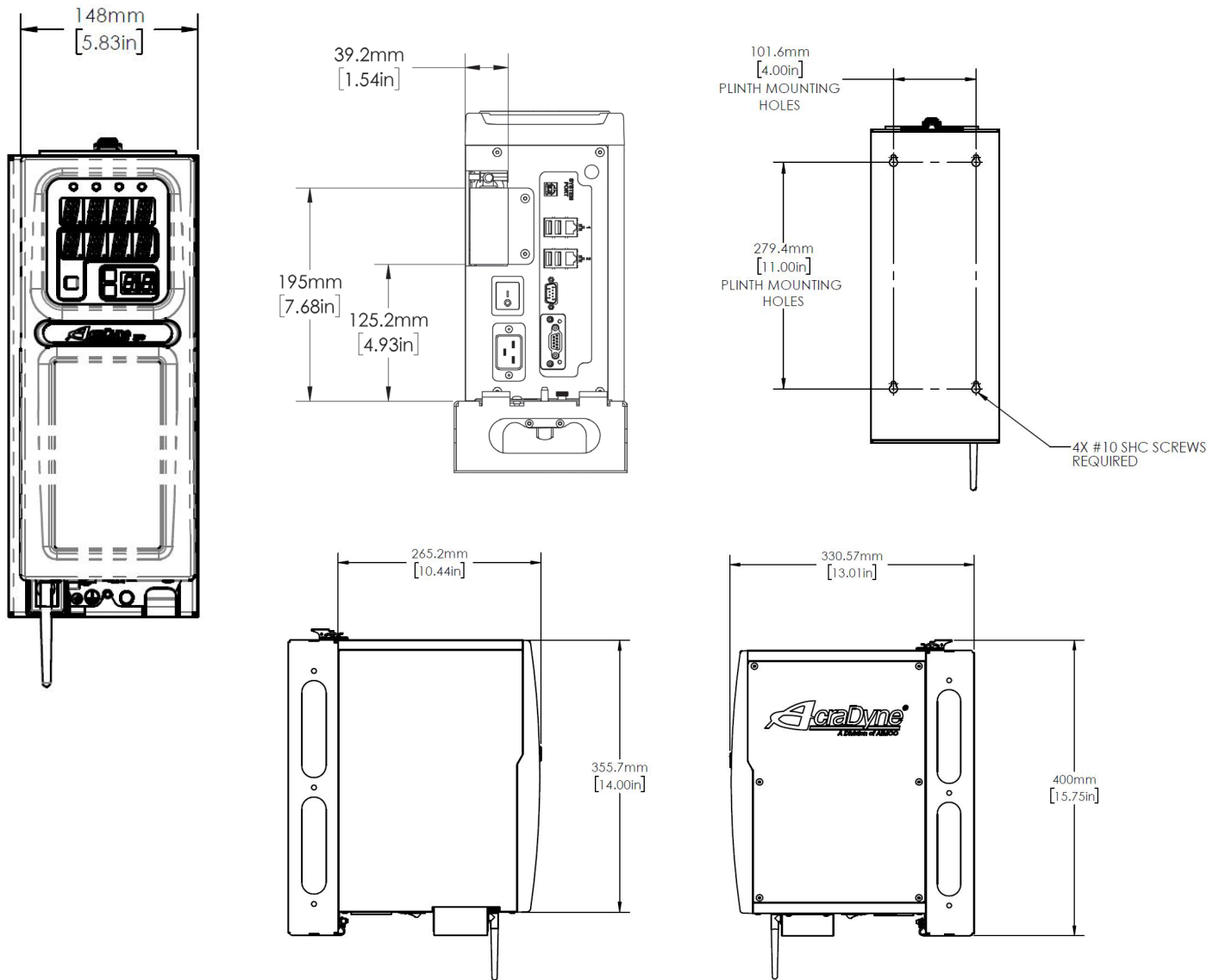

14. Specifications

Mechanical:

Dimensions	Width:	6.25 in	159 mm
	Height:	15.75 in	400 mm
	Depth:	12.5 in	316 mm
Weight:		15.0 lbs	7.1 kg

Operating Conditions:

Temperature:	32 to 122 °F (0 to 50 °C)
Humidity:	Non-condensing
Ingress Protection:	IP20

Electrical:

AC Power Source: 100 - 240 VAC, 50/60 Hz, 1Amp, 100 Watts

Standards:

Safety Compliance:

EC Machinery Directive 2006/42/EC
 EC Low Voltage Directive 2006/95/EC

EN 12100-1; EN 12100-12 Safety of Machinery
 EN 60745-1; EN 60745-2-2 Hand-held motor operated tools

EMC

EC Directive of Electromagnetic Compatibility 2004/108/EC

EN 61000-6-4; EN 6100-6-2; Class A

RoHs

Reduction of Hazardous Substances 2002/95/EC

Markings

CE

15. Troubleshooting

Issue: LED Frozen Showing "Initializing"

Solution: The rear SD card containing the system UI may have become unseated. Turn off controller power. Depending on vintage, remove the label or cover plate to access the card slot. Gently depress the card and release to unseat it. Gently then press the card into the slot until feeling and hearing the locking click indicating it is secure. Replace the label or cover plate and power the controller back on.

Issue: System Port IP Connectivity using USB Cabling

Solution: In most cases, connectivity will be automatic when connection between the controller SYSTEM PORT and a PC USB Port are made. Confirmation of the connection is noted by the presence of a USB Ethernet/RNDIS Gadget in the PC Adapter list. Should this connection not be established, specific instructions are located at the product manuals page at <https://www.aimco-global.com/manuals> under the heading **System Port Connectivity Troubleshooting for PCs.**

15. AIMCO Warranty

NEW TOOL AND ACCESSORY WARRANTY

Any new tool or accessory branded with the AIMCO, Uryu, AcraDyne or Eagle Group name, and purchased from AIMCO, or through one of its authorized distributors or agents, is warranted to the original buyer against defects in materials and workmanship for a period of one (1) year* from date of delivery. Under the terms of this warranty, AIMCO agrees, without charge, to repair or replace, at its option and Ex-Works (EXW) its authorized service centers, any product or accessory warranted hereunder proving to AIMCO's satisfaction to be defective as a result of defective workmanship or material. In order to qualify for this warranty, written notice to AIMCO must be given immediately upon discovery of such defect, at which time AIMCO will issue an authorization to return the tool. The defective item must be promptly returned to an authorized AIMCO service center with all freight charges prepaid.

REPAIRED TOOL WARRANTY

Once a tool is beyond the new product warranty period as detailed above, AIMCO will provide repair subject to the following warranty periods: pneumatic tools: 90 days*; electric tools and Acra-Feed: 90 days; battery tools: 30 days*; DC Electric tools: 90 days*

EXCLUSION FROM WARRANTY

This warranty is valid only on products purchased from AIMCO, or through its authorized distributors or agents. AIMCO shall have no obligation pursuant to the AIMCO Warranty with respect to any tools or accessories which in AIMCO's sole judgment have been altered damaged, misused, abused, badly worn, lost or improperly maintained. This Warranty is null and void if the customer, or any other person other than an authorized representative of AIMCO, has made any attempt to service or modify the tool or accessory prior to its return to AIMCO under this Warranty.

The warranty provision with respect to each such product may be amended by AIMCO from time to time in its sole discretion. The liability of AIMCO hereunder shall be limited to replacing or repairing, at its option, any defective products which are returned freight pre-paid to AIMCO or, at AIMCO's option, refunding the purchase price of such products.

AIMCO reserves the right to make periodic changes in construction or tool design at any time. AIMCO specifically reserves the right to make these changes without incurring any obligation or incorporating such changes or updates in tools or parts previously distributed.

THE AIMCO WARRANTY IS IN LIEU OF ALL OTHER WARRANTIES, EXPRESSED OR IMPLIED, AND AIMCO EXPRESSLY DISCLAIMS ANY WARRANTY OF MERCHANTABILITY OR FITNESS FOR A PARTICULAR PURPOSE. THIS WARRANTY SETS FORTH THE SOLE AND EXCLUSIVE REMEDY IN CONTRACT, TORT, STRICT LIABILITY, OR OTHERWISE.

THIS WARRANTY IS THE ONLY WARRANTY MADE BY AIMCO WITH RESPECT TO THE GOODS DELIVERED HEREUNDER, AND MAY BE MODIFIED OR AMENDED ONLY BY A WRITTEN INSTRUMENT SIGNED BY A DULY AUTHORIZED OFFICER OF AIMCO.

LIMITATION OF LIABILITY

AIMCO'S LIABILITY PURSUANT TO WARRANTY OF THE PRODUCTS COVERED HEREUNDER IS LIMITED TO REFUND OF THE PURCHASE PRICE. IN NO EVENT SHALL AIMCO BE LIABLE FOR COSTS OF PROCUREMENT OF SUBSTITUTE GOODS BY THE BUYER. IN NO EVENT SHALL AIMCO BE LIABLE FOR ANY SPECIAL, CONSEQUENTIAL, INCIDENTAL OR OTHER DAMAGES (INCLUDING WITHOUT LIMITATION, LOSS OF PROFIT) WHETHER OR NOT AIMCO HAS BEEN ADVISED OF THE POSSIBILITY OF SUCH LOSS, HOWEVER CAUSED, WHETHER FOR BREACH OR REPUDIATION OF CONTRACT, BREACH OF WARRANTY, NEGLIGENCE OR OTHERWISE. THIS EXCLUSION ALSO INCLUDES ANY LIABILITY WHICH MAY ARISE OUT OF THIRD PARTY CLAIMS AGAINST BUYER. THE ESSENTIAL PURPOSE OF THIS PROVISION IS TO LIMIT THE POTENTIAL LIABILITY OF AIMCO ARISING OUT OF THIS AGREEMENT AND/OR SALE.

NOTE: The AIMCO Warranty confers specific legal rights, however some states or jurisdictions may not allow certain exclusions or limitations within this warranty. ***Note – All warranty periods addressed herein are determined using a standard shift, eight-hour work day.**



AIMCO CORPORATE HEADQUARTERS
 10000 SE Pine Street
 Portland, Oregon 97216
 Phone: (503) 254-6600
 Toll Free: 1-800-852-1368

AIMCO CORPORATION DE MEXICO SA DE CV
 Ave. Cristobal Colon 14529
 Chihuahua, Chihuahua. 31125
 Mexico
 Phone: (01-614) 380-1010
 Fax: (01-614) 380-1019