

COMMENTS	ITEM NO.	PART NUMBER	QTY.	DESCRIPTION
	1	32360.001	1	HT PISTOL HANDLE ASSEMBLY
	2	SEE CHART	1	GEARBOX/SLIP RING ASM., HT 7000-SERIES
	3	26295	1	GEAR CASE COVER, 2500 Nm
	4	26319	3	SCREW, BHSC 6-32 X .188, 18-8 SS
	5	26897	1	CHOOSE REACTION BAR
	6	26243	1	RETAINING RING, SPIRAL, Ø2.864 X Ø2.464 X .078
NOT SHOWN	7	32481	2	LABEL, CORDLESS SERIES HT TOOLS
	8	625368000	1	BATTERY, 5.5Ah, 18V, LiON

TOOL MODEL	GEARBOX ASM
ACP4B171000A	32477
ACP4B172500A	31929

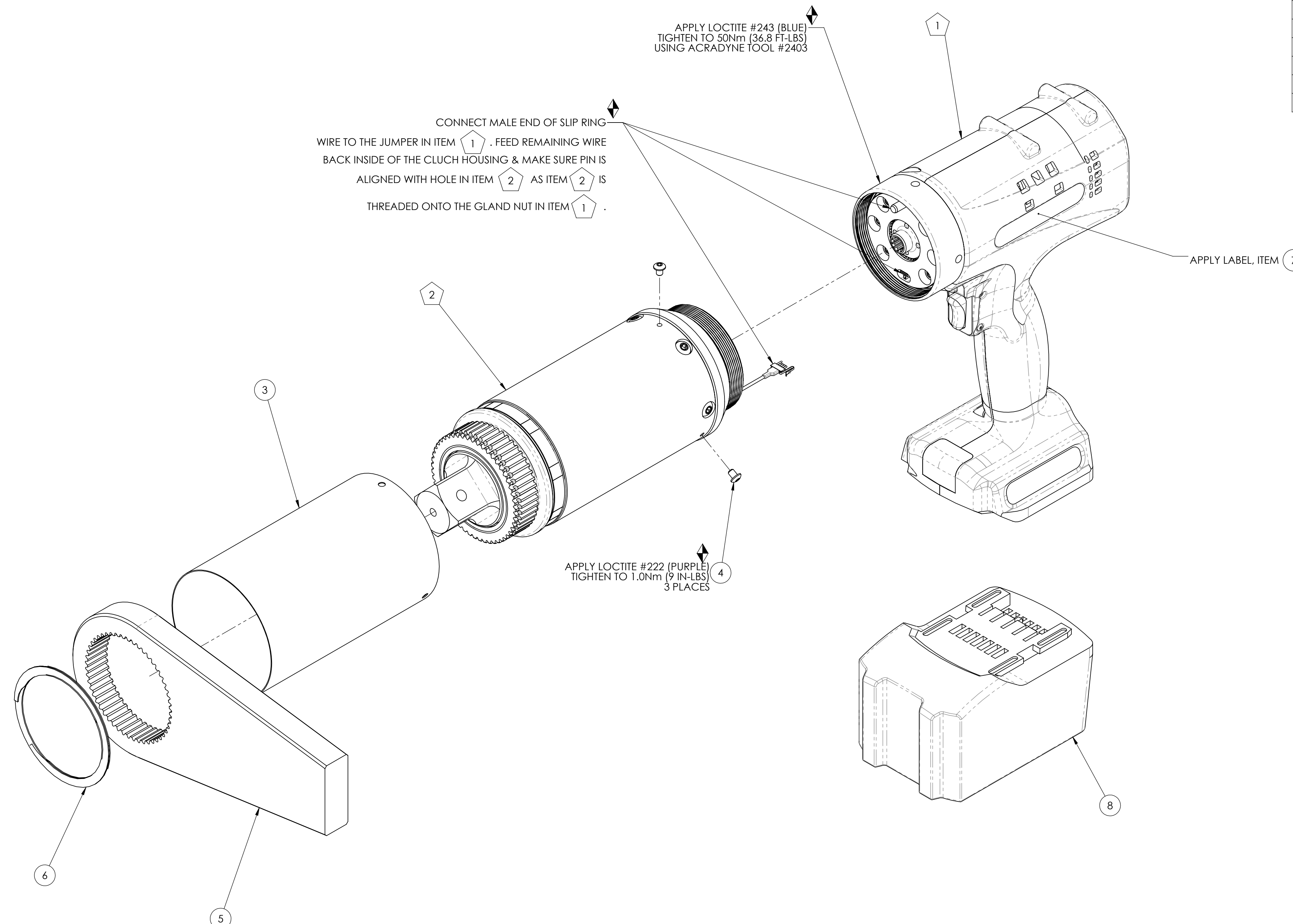

- ◆ ASSEMBLY INSTRUCTIONS
- ◊ SUB-ASSEMBLY
- 1) GEARS & SPLINES: LUBRICATE WITH DOW CORNING MOLYKOTE BR2 PLUS GREASE.
- 2) BEARINGS: LUBRICATE WITH CHEVRON SR1 GREASE
- 3) O-RINGS: LUBRICATE WITH O-RING LUBE



DOCUMENT CONTROL
 PRINTED COPIES OF THIS DOCUMENT ARE CONSIDERED TO BE UNCONTROLLED DOCUMENTS. HOLDERS ARE RESPONSIBLE FOR VERIFYING THE CURRENT REVISION LEVEL WITH PURCHASING OR ENGINEERING PRIOR TO USE OR FABRICATION. THE CONTROLLED VERSION OF THIS DOCUMENT IS ELECTRONICALLY MAINTAINED.

PROPRIETARY AND CONFIDENTIAL
 THIS DRAWING CONTAINS INFORMATION STRICTLY CONFIDENTIAL TO ACRADYNE/AIMCO. IN THE ABSENCE OF EXPRESSED WRITTEN PERMISSION, ACRADYNE/AIMCO HAS LOANED THIS COPY WITH THE MUTUAL UNDERSTANDING THAT (A) IT WILL NOT BE USED FOR ANY PURPOSE OTHER THAN FOR THAT IN WHICH IT WAS PROVIDED, (B) THE DATA CONTAINED HEREIN WILL NOT BE DISCLOSED TO OTHERS, (C) IT WILL NOT BE REPRODUCED, AND (D) IT WILL BE RETURNED TO ACRADYNE/AIMCO IMMEDIATELY UPON DEMAND.

REVISION LEVEL	REVISION RELEASE DATE	DESCRIPTION OF CHANGES MADE TO PART	ECN #	AUTHOR/ APPROVAL

UNLESS OTHERWISE SPECIFIED, DIMENSIONS ARE IN INCHES
 DIMENSIONS AND TOLERANCING PER ANSI Y14.5
 SURFACE ROUGHNESS PER ANSI Y14.36

BLOCK TOLERANCING PER DECIMAL:
 X = ±.030 XX = ±.010 XXX = ±.005 XXXX = ±.0005
 ANGLE = ±0° 30'

REMOVE BURRS AND SHARP EDGES: R.015 MAX
 MACHINE SURFACE FINISH: 125 RMS OR BETTER

HT PISTOL NUTRUNNER, 7000 SERIES
CORDLESS SERIES

SIZE	PART / DRAWING NUMBER	REVISION
D	ACP4B17___A	A

SCALE: 1:1 DO NOT SCALE DRAWING SHEET 1 OF 2

REVISION BLOCK

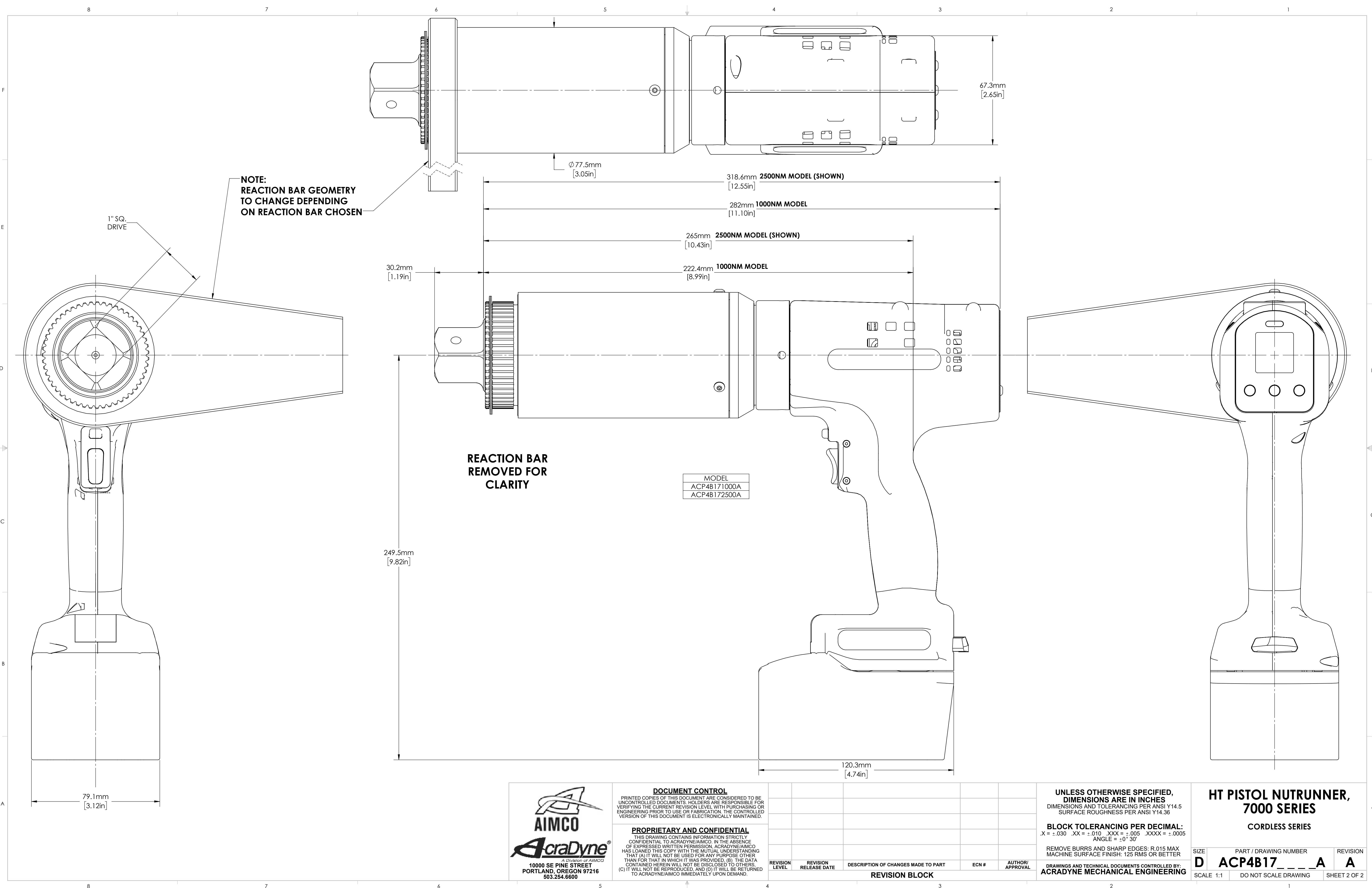

NOTE:
REACTION BAR GEOMETRY
TO CHANGE DEPENDING
ON REACTION BAR CHOSEN

1" SQ.
DRIVE

REACTION BAR
REMOVED FOR
CLARITY

MODEL
ACP4B171000A
ACP4B172500A

REVISION LEVEL	REVISION RELEASE DATE	DESCRIPTION OF CHANGES MADE TO PART	ECN #	AUTHOR/ APPROVAL

UNLESS OTHERWISE SPECIFIED,
DIMENSIONS ARE IN INCHES
DIMENSIONS AND TOLERANCING PER ANSI Y14.5
SURFACE ROUGHNESS PER ANSI Y14.36

BLOCK TOLERANCING PER DECIMAL:
X = ±.030 XX = ±.010 XXX = ±.005 XXXX = ±.0005
ANGLE = ±0° 30'

REMOVE BURRS AND SHARP EDGES: R.015 MAX
MACHINE SURFACE FINISH: 125 RMS OR BETTER

DRAWINGS AND TECHNICAL DOCUMENTS CONTROLLED BY:
ACRADYNE MECHANICAL ENGINEERING

**HT PISTOL NUTRUNNER,
7000 SERIES**

CORDLESS SERIES

SIZE D	PART / DRAWING NUMBER ACP4B17__A	REVISION A
SCALE 1:1	DO NOT SCALE DRAWING	SHEET 2 OF 2

AIMCO
AcraDyne
A Division of AIMCO
10000 SE PINE STREET
PORTLAND, OREGON 97216
503.254.6600

DOCUMENT CONTROL
PRINTED COPIES OF THIS DOCUMENT ARE CONSIDERED TO BE UNCONTROLLED DOCUMENTS. HOLDERS ARE RESPONSIBLE FOR VERIFYING THE CURRENT REVISION LEVEL WITH PURCHASING OR ENGINEERING PRIOR TO USE OR FABRICATION. THE CONTROLLED VERSION OF THIS DOCUMENT IS ELECTRONICALLY MAINTAINED.

PROPRIETARY AND CONFIDENTIAL
THIS DRAWING CONTAINS INFORMATION STRICTLY CONFIDENTIAL TO ACRADYNE/AIMCO. IN THE ABSENCE OF EXPRESSED WRITTEN PERMISSION, ACRADYNE/AIMCO HAS LOANED THIS COPY WITH THE MUTUAL UNDERSTANDING THAT (A) IT WILL NOT BE USED FOR ANY PURPOSE OTHER THAN FOR THAT IN WHICH IT WAS PROVIDED, (B) THE DATA CONTAINED HEREIN WILL NOT BE DISCLOSED TO OTHERS, (C) IT WILL NOT BE REPRODUCED, AND (D) IT WILL BE RETURNED TO ACRADYNE/AIMCO IMMEDIATELY UPON DEMAND.