

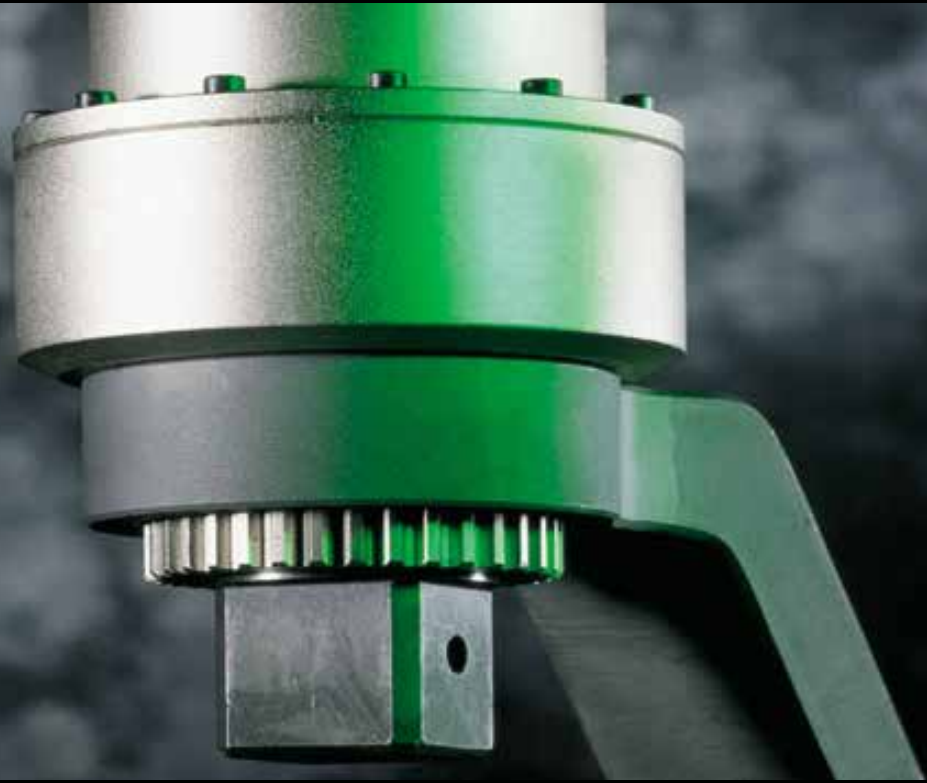

MANUAL TORQUE MULTIPLIERS



DynaTorque

THE DRIVING FORCE IN CRITICAL BOLTING

AIMCO is the source for your fastening, tightening, and critical bolting needs. AIMCO possesses over 40 years experience in joint tightening and its interaction with tooling which ensures the best solution is put into practice.

If Productivity, Ergonomics, Reliability, and Quality are driving forces in your business, then AIMCO is your value-added partner. We provide cost effective answers for our customers by working collaboratively to solve challenges related to tightening strategies, tool selection and installation, joint failure analysis, as well as audit trails and methods. As a value added service, AIMCO will train your operators to maximize the production efficiencies our tools provide.

AIMCO's manufacturing division, AcraDyne, located in Portland, Oregon produces one of the world's most complete lines of D/C Controlled Tools, innovative new products, and engineered solutions to complex fastening and bolting challenges. Our service, repair, and calibration labs provide a fast turnaround on repairs and all electronic torque equipment are traceable to NIST standards.

Our strategically located Sales Organization, coupled with our worldwide Service Providers, make AIMCO the right choice for all of your fastening, tightening, and critical bolting needs.



DynaTorque MANUAL TORQUE MULTIPLIERS

The ultimate solution for saving time and power

CONSTRUCTION FEATURES

- Compact design for use in tight spaces.
- High strength planetary gears
- Tempered steel internal components.
- No-maintenance permanent internal greasing.
- Anti-Wind Up feature
- Phosphatized Chrome Plated external finish.



Casing

Finished in Phosphatized Chrome.

Reaction Bar

Standard offset reaction bar supplied with each unit. Custom Reaction Bars available to suit specific applications (by quotation).

Shear Design Drive

- External drive fitted with shear design for overload protection.
- Spare drive supplied with each unit.
- Simple, field replaceable design.

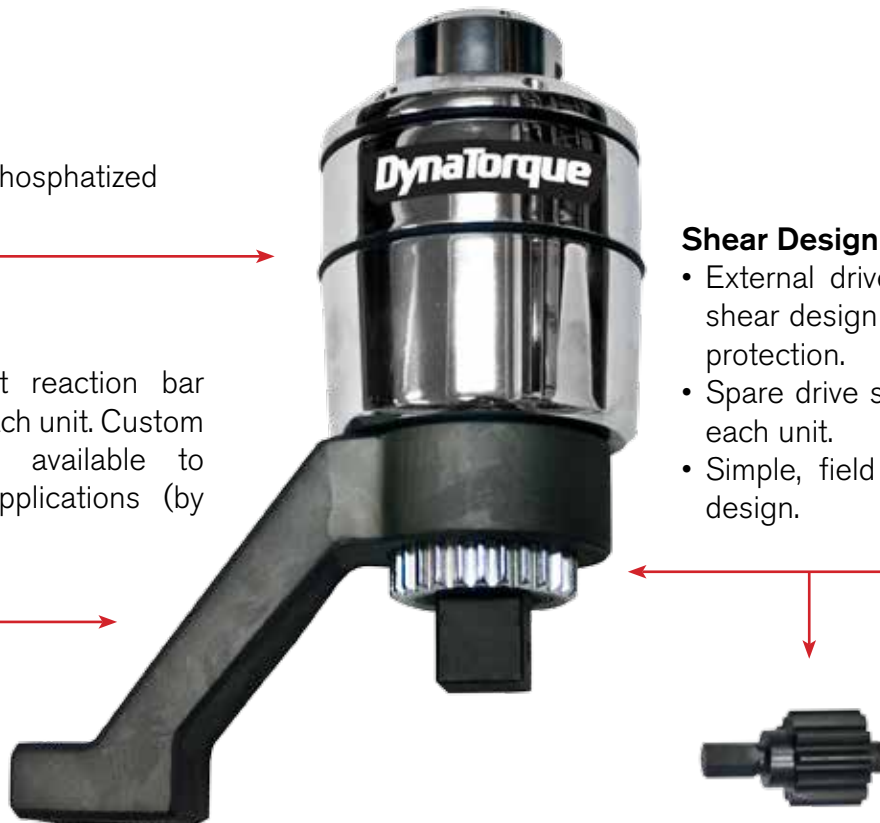

FEATURES AND BENEFITS

Manual Torque Multipliers offer the perfect, economical solution to high torque bolting applications.

- Superior power to weight ratio.
- Delivered torque accuracy +/- 4%.
- Anti-Wind Up feature (2800NM models and up).
- True Torque Multiplication Ratios.
- Standard Reaction Arms supplied. Custom reaction arms/nose extensions available to suit specific applications.
- Replaces long lever arms and/or slugging wrenches.
- Manually powered – no external power source required.
- Value priced.
- No preventative maintenance required.
- Overload protected by Shear Drive design.



ANTI-WIND UP FEATURE

Standard on models delivering 2800NM and up.

- Eliminates the backward force on the torque input device.
- Insures safe operation by the operator by not allowing the input device to spring backward when released.
- Eliminates the need to continually rotate the input device in 360 degree movements to apply torque. In many applications this is simply not possible.
- Facilitates removal of the multiplier from the application upon completion of the job.

SHEAR-OFF SYSTEM

In order to protect the gear system against overload, DynaTorque Multipliers are fitted with a controlled shear-off system (spare torsion shaft included). Sheared off pins can easily be replaced at the work site.

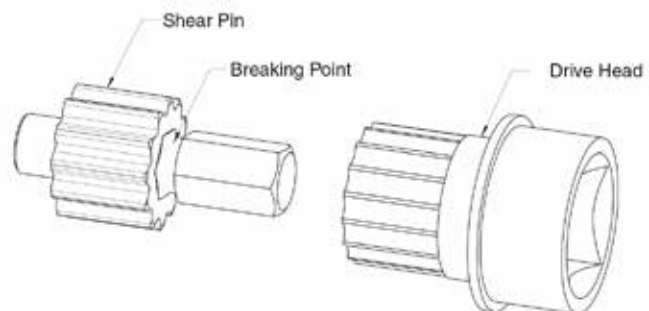

SPECIFICATIONS

	MODEL	INPUT in	OUTPUT in	RATIO	MAX TORQUE OUTPUT	
					ft-lb	Nm
	ATM-800	1/2	3/4	1:3.5	590	800
	ATM-1800	3/4	1	1:3.6	1238	1800
	ATM-2800	1/2	1	1:13	2066	2800
	ATM-3800	3/4	1	1:13	2804	3800
	ATM-5000	3/4	1.5	1:17	3690	5000
	ATM-8000	3/4	1.5	1:49	5904	8000
	ATM-12000	3/4	1.5	1:58	8856	12000
	ATM-16000	3/4	2.5	1:75	11808	16000

SPECIFICATIONS

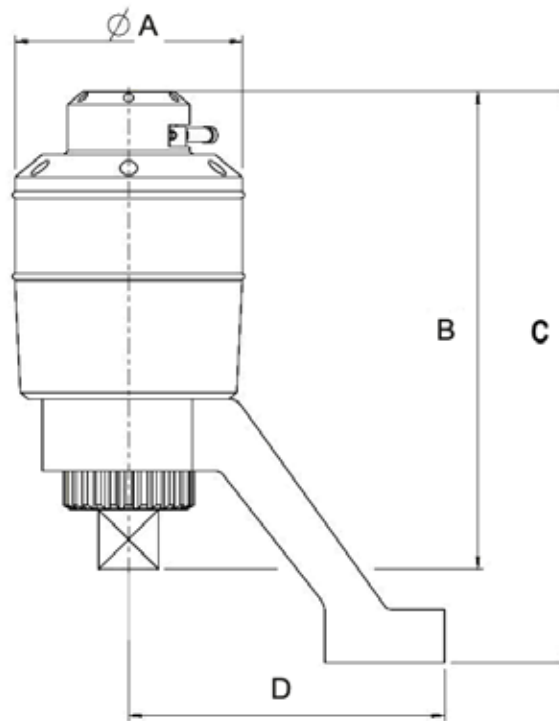

	A (MM)	B (MM)	C (MM)	D (MM)	WEIGHT*	
					LB	KG
ATM-800	65	105	132	130	2.9	1.3
ATM-1800	90	150	188	132	6.6	3.0
ATM-2800	95	200	240	132	11.5	5.2
ATM-3800	95	200	240	132	11.5	5.2
ATM-5000	120	215	272	150	15.4	7.0
ATM-8000	132	268	344	200	25.4	11.5
ATM-12000	156	272	348	200	30.9	14.0
ATM-16000	215	292	370	225	57.3	26.0

* Weight shown does not include weight of reaction device.

DynaTorque

ACCESSORIES

CARRYING CASE

- All DynaTorque Multipliers are supplied in a rugged, weather-resistant, portable carrying case.



REACTION BARS

Each tool includes a standard, offset reaction bar. Although a wide variety of applications are easily tightened using the standard bar, many applications are unique in nature. AIMCO offers design consultation and specialized reaction bar designs to suit your specific needs. Contact your AIMCO sales representative for more details on these services, 1-800-852-1368.

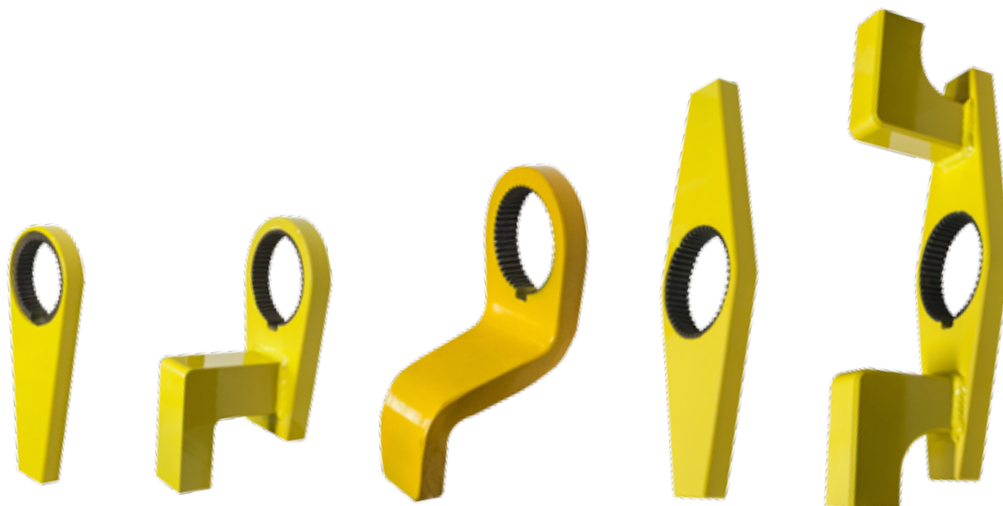

APPLICATIONS - PARTIAL REFERENCES

POWER



**EQUIPMENT
FIELD REPAIR**

SHIPYARD



STEEL MILL

**OFFSHORE AND
EXPLORATION**



PETROCHEM

MINING



LOCOMOTIVE



AIMCO Headquarters
PO Box 16460
Portland, Oregon 97216
Phone: 800-852-1368

AIMCO Mexico
Ave. Cristobal Colon 14529
Chihuahua, Chihuahua 31125
Toll Free: (01-800)801-1600
Direct: (01-614)380-1010
Fax: (01-614)380-1019

AIMCO China
Room 607, Dibao Plaza
No.3998 Hongxin Rd,
Minhang District,
Shanghai, 201103
Phone: 86-21-34319246
Fax: 86-21-34319245

AIMCO Europe
Avenida Río Gallo, 431
19174 Galápagos
Guadalajara
Phone: 34 673 34 99 25

www.aimco-global.com

ISO 9001: 2015 Certified

