

AIMCO

POWER TOOLS





For over 40 years AIMCO has been working with manufacturers around the world, we are the complete global source for all assembly, fastening, and critical bolting needs. AIMCO can effectively and swiftly meet your needs whether you're in Thailand fastening a 3 mm nut at 3 Nm, or in Tennessee, USA torquing the last lug nut. AIMCO provides the tools and solutions, on a global scale, that guarantee the success of your project. It is with great pride that AIMCO can say the products that we manufacture are **MADE IN THE USA.**

ISO 9001: 2015 Certified

Visit our NEW website www.aimco-global.com

TABLE OF CONTENTS

POWER TOOLS

AIMCO PULSE TOOLS: OVERVIEW	3-5
UAT SERIES	6-7
OMEGA PULSE TOOLS: UL SERIES.	8
ACRA-PULSE® SERIES	9-11
UDBP PULSE SERIES CORDLESS TOOLS.	12-13
UDP-TA SERIES	14
NUTRUNNERS: OVERVIEW.	15
NUTRUNNERS.	16-17
DYNATORQUE MANUAL TORQUE MULTIPLIERS	18-19
SCREWDRIVERS: OVERVIEW	20
PNEUMATIC SCREWDRIVERS	21-23
SIGNATURE SERIES CORDLESS TOOLS	24-26
ELECTRIC SCREWDRIVERS	27-29
IMPACT TOOLS	30
GRINDERS AND SANDERS.	31
DRILLS & PERCUSSION TOOLS	32



* **E** logo indicates where ERGO-DRIVE sockets/extensions benefit tool operation.

ERGO-DRIVE sockets are uniquely designed to seat deeper on the tool anvil while an O-ring inside the socket fits tight onto the anvil to reduce vibration. By reducing run-out and vibration, ERGO-DRIVE sockets allow the most repeatable, accurate rundowns, ensuring excellent product quality, longer tool life, and better ergonomics for the tool user.

Look for the ERGO-DRIVE **E** logo in this catalog to see where ERGO-DRIVE sockets/extensions benefit tool operation, operator, and rundown.

AIMCO PULSE TOOLS: OVERVIEW

HOW DOES A PULSE TOOL WORK?

The unique design of a pulse tool, combining motor power and hydraulics, leads to an assembly tool that produces smooth, controlled torque in a series of very fast (2 – 4 ms) events and virtually no torque reaction.

- At free-speed, the entire pulse unit, a sealed cylinder containing hydraulic fluid and an output shaft, rotates at the same speed as the tool motor.
- As resistance to rotation increases, the rotation of the output shaft slows, while the rotation of the

cylinder and the hydraulic fluid continues until they approach a seal point within the cylinder.

- This seal point produces an increase in fluid pressure and transmits the energy from the rotational mass of the cylinder and fluid to the output shaft, producing torque on the fastener.
- After a series of these cycles (pulses), fluid pressure builds to a point that overcomes the limit of a relief valve, allowing pressure to drop and torque to be controlled

TIMELINE

1965

NEW TECHNOLOGY

The first pulse tool prototype was designed in an attempt to provide a tool that would provide torque control without the high maintenance costs of impact wrenches.



1980

U SERIES

Uryu produces the U-series, the first pulse tools to be available commercially for assembly. The U-Series evolves over the next several years to cover torque ranges from 4 – 850 Newton meters and finally, the development of full-shut-off tools. The lack of torque reaction and accurate, repeatable torque makes these tools a manufacturer standard.



1988

EC SERIES

The EC Series (and later the MC Series) combines the advantages of pulse tools with the technology of controlled tools. By incorporating a transducer into the design of the U-Series pulse tool, customers gain the Productivity and Ergonomics of pulse tools and the traceability and control of other transducerized assembly tools. Manufacturers with safety critical applications now have many more options for assembly tools.



2006

UEP-MC SERIES

Uryu does what no other manufacturer can by developing the UEP series, the first and only electric powered pulse tool. The lower speeds, quiet operation, and extremely repeatable torque make the UEP the perfect choice for applications where accuracy and clean operation are critical. By combining programmable tool speed with the MC-style transducer, extremely accurate and repeatable torque is achieved on a variety of applications.



2012

UDP-MC CONTROLLED SERIES

Uryu introduced the UDP-MC controlled series – smaller, lighter electric pulse tools that have an integrated fan unit. The state-of-the-art UECD controller with a built-in driver box eliminates the need for a secondary driver box in the system configuration.



OMEGA PULSE TOOLS: OVERVIEW

BENEFITS OF AIMCO PULSE TOOLS:

Pulse tools offer advantages in all of the PERQ® elements – productivity, ergonomics, reliability and quality.

By partnering with AIMCO, manufacturers can apply the advantages of pulse tools in many ways to reduce production costs and increase profits.

- Productivity – Combining high operating speeds with one-handed operation, AIMCO pulse tools help manufacturers produce at the highest possible rates.
- Ergonomics – Light weight, low vibration and no torque reaction make AIMCO pulse tools the safest assembly tools available for threaded assembly.
- Reliability – Advances in design and AIMCO's extensive maintenance and training programs add up to years of low cost service from any AIMCO pulse tool.
- Quality – AIMCO pulse tools offer the most repeatable torque and clamp load results of any assembly tool, guaranteeing high product quality for manufacturers.

1995

ALPHA SERIES

The Alpha-series continued Uryu's advancements in pulse-tool design. In order to achieve the best possible power-to-weight ratio, the Alpha 9-blade, twin chamber air motor is developed. Still unique today, this new motor provides significantly more power, thereby, reducing cycle times and improving torque repeatability. The new Alpha air motor and design changes make the tools smaller and lighter, keeping Uryu at the forefront of pulse tool technology.



2001

ULT / UL SERIES

Continuous innovations and developments include a new O-ring design that improves durability, roller bearings in the pulse unit to increase hydraulic fluid life and redesigned porting helps maintain fluid temperature and torque repeatability. UL tools, with their non-shut off operation, are ideal for applications where the lightest, fastest tool is necessary. Each model features the powerful Alpha air motor and latest in pulse unit design.



2013

UA-AMC CONTROLLED PULSE SERIES

The UA-AMC Series features angle measurement for improved process control. It detects cross threading, double hits on the same fastener, stripped and damaged fastener threads and incorrect fasteners. It also features patented Auto Relief Technology, which modulates the beginning of the torque event, increases pulse frequency, and reduces resistance during the non-pulsing portion of the cycle. This shortens cycle time and increases fluid life.



UAT SERIES

In 2013, Uryu developed and patented the latest innovation in Pulse Tool technology. Auto Relief (PAT) enables efficient delivery of torque energy to the application. Auto Relief responds to ever-changing pressures in the pulse unit, applying its energy in a smooth manner to the joint as the torque is developed. The Auto Relief valve is fully open during free run and automatically closes when torque resistance is sensed. No adjustment required. Benefits include elimination of initial torque spike on hard joints, reduction in oil flow resistance, and maximized performance of the tool.



OMEGA PULSE TOOLS: UAT SERIES

PATENTED AUTO RELIEF TECHNOLOGY:

UAT features patented Auto Relief Technology providing additional control to the application of torque during the pulsing events.

- Auto Relief eliminates initial spike of torque during a cycle. Highly effective on hard joint applications.
- Auto Relief ramps up pressure within the pulse unit resulting in more pulses in less time providing a more efficient and even torque event.

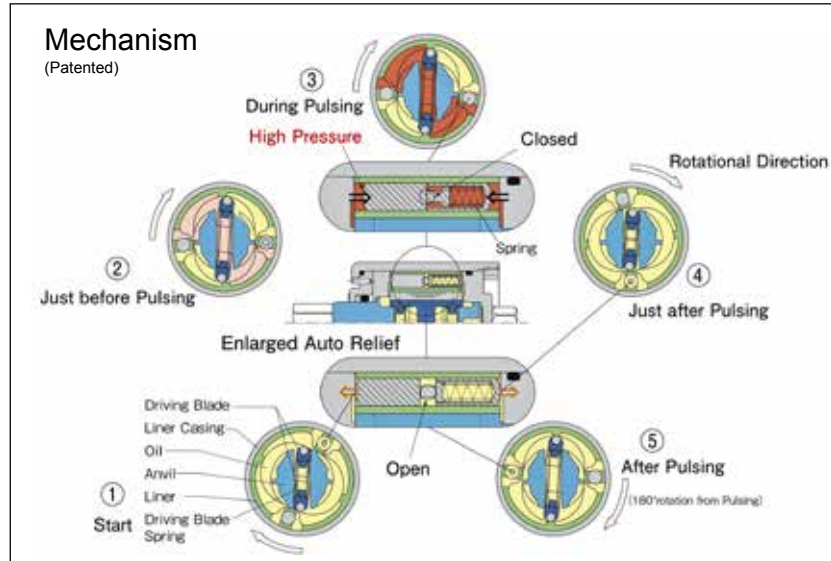

A NEW LEAP FORWARD IN PRODUCTIVITY AND QUALITY:

- Fastening accuracy and time can be improved by as much as 30% depending on application.

■ Fastening efficiency comparison (UAT vs ULT)

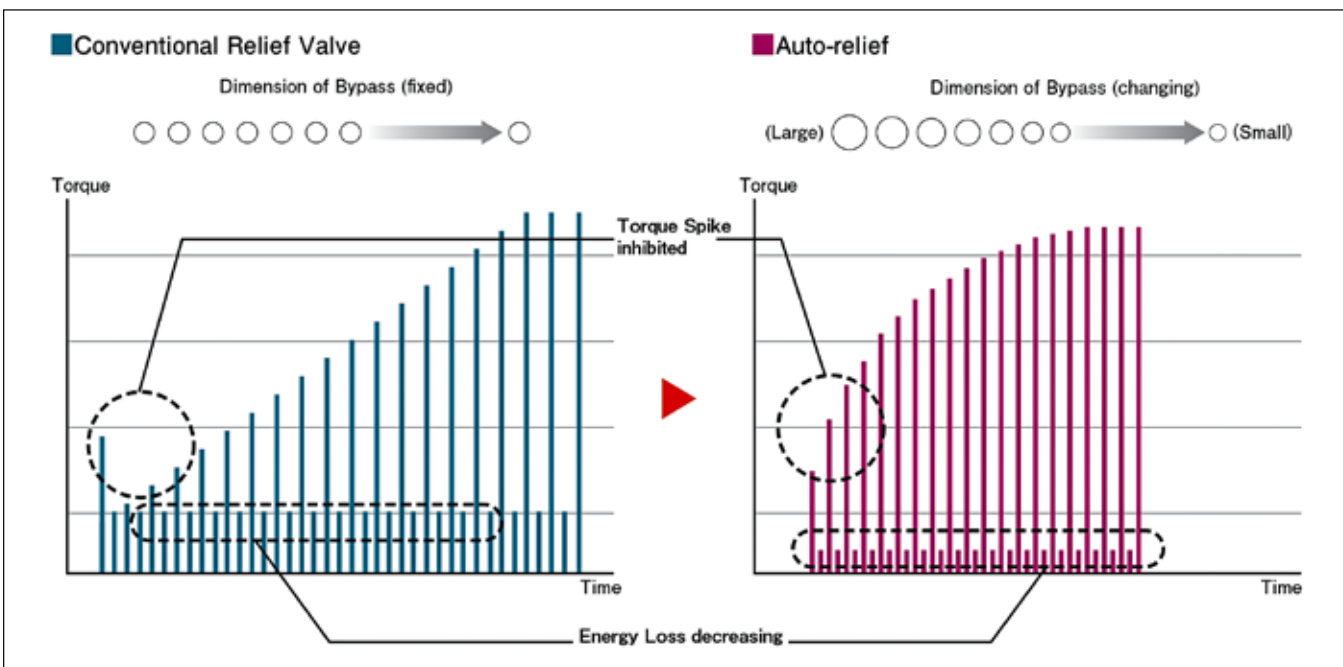
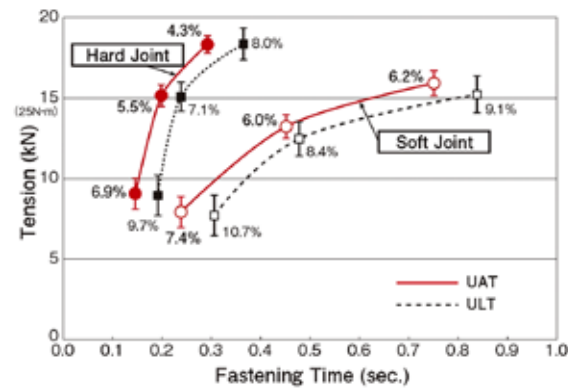

OMEGA PULSE TOOLS: UAT SERIES



Pistol Shut-Off

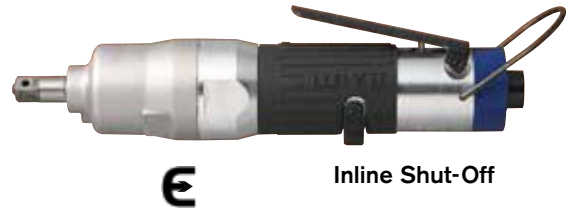

Inline Shut-Off

PISTOL SHUT-OFF

Recommended Air Pressure: 85 psi

MODEL	FREE SPEED rpm	TORQUE RANGE		WEIGHT		OVERALL LENGTH		DRIVE in	SOUND LEVEL dB(A)	AIR USAGE cfm
		Nm	ft-lb	lb	kg	in	mm			
UAT-30D	4,200	2.5 - 5.5	1.9 - 4.1	1.9	0.9	6.5	165	1/4	76	10.5
UAT-40	3,800	4.5 - 8.0	3.3 - 5.9	2.0	0.9	6.4	162	3/8	75	8.8
UAT-40D	3,800	4.5 - 8.0	3.3 - 5.9	2.0	0.9	6.5	165	1/4	75	8.8
UAT-50	4,600	7.0 - 15.5	5.2 - 11.5	2.0	0.9	6.4	162	3/8	78	8.8
UAT-50D	4,600	7.0 - 15.5	5.2 - 11.5	2.0	0.9	6.5	165	1/4	78	8.8
UAT-50L	4,000	7.0 - 15.5	5.2 - 11.5	2.0	0.9	6.4	162	3/8	75	8.8
UAT-50DL	4,000	7.0 - 15.5	5.2 - 11.5	2.0	0.9	6.5	165	1/4	75	8.8
UAT-60	6,700	15.0 - 32.0	11.1 - 23.7	2.1	1.0	6.8	174	3/8	80	12.3
UAT-60D	6,700	15.0 - 32.0	11.1 - 23.7	2.1	1.0	7.0	177	1/4	80	12.3
UAT-60L	6,000	13.0 - 28.0	9.6 - 20.7	2.1	1.0	6.8	174	3/8	77	8.8
UAT-70	6,000	30.0 - 55.0	22.2 - 40.7	2.3	1.1	7.1	180	3/8	80	14.0
UAT-70L	5,300	25.0 - 48.0	18.5 - 35.5	2.3	1.1	7.1	180	3/8	78	10.5
UAT-80	5,600	45.0 - 63.0	33.3 - 46.6	2.8	1.3	7.3	186	3/8	80	16.8
UAT-80L	5,300	35.0 - 55.0	25.9 - 40.7	2.8	1.3	7.3	186	3/8	78	14.0
UAT-90	5,700	50.0 - 85.0	37.0 - 62.9	3.2	1.5	7.6	192	1/2	82	18.6
UAT-90L	5,100	45.0 - 75.0	33.3 - 55.5	3.2	1.5	7.6	192	1/2	79	15.8
UAT-100	5,200	70.0 - 130.0	51.8 - 96.2	3.7	1.7	7.8	199	1/2	82	19.3
UAT-100L	5,200	60.0 - 110.0	44.4 - 81.4	3.7	1.7	7.8	199	1/2	79	16.8
UAT-130	4,500	110.0 - 150.0	81.4 - 111	5.1	2.3	8.5	217	1/2	82	24.6
UAT-200	2,400	200.0 - 400.0	148.0 - 296.0	12.8	5.8	11.0	279	3/4	85	35.2

Air Hose Size: 1/4" ID for UAT-30 to UAT-50, 3/8" ID for UAT-60 to UAT-100, 1/2" ID for UAT-130 to UAT-200

Air Inlet Thread: 1/4" NPT for UAT-30 to UAT-100 3/8" NPT for UAT-130 to UAT-200

Note Torque Ranges reflect residual B joint torque values

UAT Models containing "D" indicate 1/4" quick change bit holder

UAT Models containing "L" indicate models designed to run at 57 PSI air pressure.

Most models can be equipped with TM (Tightening Monitor) feature for use with qualifier systems. Order TM tools by adding "TM" to model number (for example, UAT-60 becomes UAT-60TM).

INLINE SHUT-OFF

Recommended Air Pressure: 85 psi

MODEL	FREE SPEED rpm	TORQUE RANGE		WEIGHT		OVERALL LENGTH		DRIVE in	SOUND LEVEL dB(A)	AIR USAGE cfm
		Nm	ft-lb	lb	kg	in	mm			
UAT-30SD	3,400	2.5 - 5.5	1.9 - 4.1	1.9	0.8	8.7	222	1/4	68	12.3
UAT-40S	3,300	4.5 - 8.0	3.3 - 5.9	1.9	0.9	8.8	224	3/8	70	7.0
UAT-40SD	3,300	4.5 - 8.0	3.3 - 5.9	1.9	0.9	8.9	227	1/4	70	7.0
UAT-50S	3,900	7.0 - 15.5	5.2 - 11.5	1.9	0.9	8.8	224	3/8	78	8.8
UAT-50SD	3,900	7.0 - 15.5	5.2 - 11.5	1.9	0.9	8.9	227	1/4	78	8.8
UAT-50SL	3,800	7.0 - 15.5	5.2 - 11.5	1.9	0.9	8.8	224	3/8	75	7.0
UAT-50SDL	3,800	7.0 - 15.5	5.2 - 11.5	1.9	0.9	8.9	227	1/4	75	7.0
UAT-60S	5,700	15.0 - 32.0	11.1 - 23.7	1.9	0.9	9.0	229	3/8	80	10.5
UAT-60SD	5,700	15.0 - 32.0	11.1 - 23.7	1.9	0.9	9.1	232	1/4	80	10.5
UAT-60SL	5,300	13.0 - 28.0	9.6 - 20.7	1.9	0.9	9.0	229	3/8	77	8.8
UAT-60SDL	5,300	13.0 - 28.0	9.6 - 20.7	1.9	0.9	9.1	232	1/4	77	8.8
UAT-70S	4,700	30.0 - 50.0	22.2 - 37.0	2.1	1.0	9.4	239	3/8	80	12.3
UAT-70SL	4,400	25.0 - 45.0	18.5 - 33.3	2.1	1.0	9.4	239	3/8	78	9.5

Air Hose Size: 1/4" ID for UAT-30 to UAT-50, 3/8" ID for UAT-60 to UAT-70

Air Inlet Thread: 1/4" NPT for UAT-30 to UAT-70

Note Torque Ranges reflect residual B joint torque values

UAT Models containing "D" indicate 1/4" quick change bit holder

UAT Models containing "L" indicate models designed to run at 57 PSI air pressure.

Most models can be equipped with TM (Tightening Monitor) feature for use with qualifier systems. Order TM tools by adding "TM" to model number (for example, UAT-60 becomes UAT-60TM).

*  logo indicates where ERGO-DRIVE sockets/extensions benefit tool operation.

OMEGA PULSE TOOLS: UL SERIES

OMEGA UL SERIES

Whether the goal is improving productivity, ergonomics, reliability, or quality, the UL Series contains the technology to achieve success.

FEATURES AND BENEFITS

- Models available from 6 – 260 Nm (4.4 – 170 FtLb)
- Models with air, electric, or battery power.
- Available in Standard, Tightening Monitor, and Transducerized versions.
- High power-to-weight ratio
- Simple operation
- Reduced Maintenance
- Extended service life
- Environmentally friendly design.
- Accurate and repeatable



UL-50

Omega Series Pulse Unit

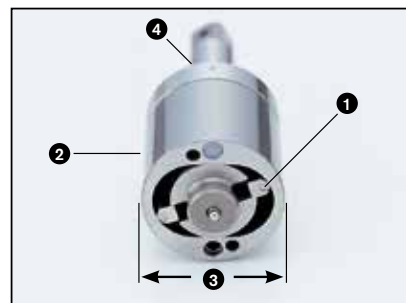

- 1 Roller bearings – reduced friction.
- 2 Accumulator – stable fluid temperature.
- 3 Reduced size – lightweight tools.
- 4 New O-ring design – better durability

Recommended Air Pressure: 85 psi

UL SERIES PISTOL NON SHUT-OFF

MODEL	FREE SPEED	TORQUE RANGE		WEIGHT		OVERALL LENGTH		DRIVE	SOUND LEVEL	AIR USAGE
	rpm	Nm	ft-lb	lb	kg	in	mm	in	dB(A)	cfm
UL-30D	5,700	6 - 12	4.4 - 8.9	1.5	0.7	5.4	137	1/4 hex	75	7.0
UL-30	5,700	6 - 12	4.4 - 8.9	1.5	0.7	5.2	133	3/8 sq.	75	7.0
UL-40D	6,100	11 - 20	8.1 - 14.8	1.5	0.7	5.4	137	1/4 hex	75	7.0
UL-40	6,100	13 - 22	9.6 - 16.3	1.5	0.7	5.2	133	3/8 sq.	75	7.0
UL-50D	6,400	18 - 28	13.3 - 20.7	1.7	0.8	5.8	146	1/4 hex	78	10.5
UL-50	6,400	22 - 35	16.3 - 25.9	1.7	0.8	5.5	140	3/8 sq.	78	10.5
UL-60D	7,000	22 - 35	16.3 - 25.9	1.8	0.8	5.6	143	1/4 sq.	80	14.0
UL-60	7,000	32 - 50	23.7 - 37.0	1.8	0.8	5.5	140	3/8 sq.	80	14.0
UL-70	5,700	40 - 65	29.6 - 48.1	2.1	1.0	6.0	153	3/8 sq.	80	15.8
UL-80	5,900	45 - 70	33.3 - 50.0	2.5	1.1	6.4	162	3/8 sq.	80	16.8
UL-90	6,000	60 - 100	44.4 - 74.0	2.9	1.3	6.7	170	1/2 sq.	82	18.6
UL-100	5,400	80 - 130	59.2 - 96.2	3.7	1.7	7.0	177	1/2 sq.	80	20.3
UL-130	4,400	100 - 160	74.0 - 118.4	5.1	2.3	7.8	197	1/2 sq.	83	22.7
UL-150	3,800	150 - 230	109.9 - 169.6	6.6	3.0	8.4	213	3/4 sq.	84	24.7

UL SERIES INLINE NON SHUT-OFF

UL-50S



Recommended Air Pressure: 85 psi

MODEL	FREE SPEED	TORQUE RANGE		WEIGHT		OVERALL LENGTH		DRIVE	SOUND LEVEL	AIR USAGE
	rpm	Nm	ft-lb	lb	kg	in	mm	in	dB(A)	cfm
UL-30SD	5,000	6 - 12	4.4 - 8.9	1.4	0.6	8.2	209	1/4 hex	75	8.1
UL-30S	5,000	6 - 12	4.4 - 8.9	1.4	0.6	8.1	205	3/8 sq.	72	8.1
UL-40SD	5,000	9 - 20	6.7 - 14.8	1.4	0.6	8.2	209	1/4 hex	75	8.1
UL-40S	5,000	11 - 22	8.1 - 16.3	1.4	0.6	8.1	205	3/8 sq.	72	8.1
UL-50SD	6,400	18 - 28	13.3 - 20.7	1.6	0.7	8.4	214	1/4 hex	78	12.3
UL-50S	6,400	22 - 35	16.3 - 25.9	1.6	0.7	8.2	208	3/8 sq.	78	12.3
UL-60SD	6,700	22 - 35	16.3 - 25.9	1.7	0.8	8.3	212	1/4 hex	80	15.8
UL-60S	6,700	32 - 50	23.7 - 37.0	1.7	0.8	8.2	209	3/8 sq.	80	15.8
UL-70S	5,400	36 - 60	26.6 - 44.4	1.9	0.9	8.8	223	3/8 sq.	84	14.0

Air Hose Size: 1/4 I.D. for UL-30 (D/SD) - UL-50 (D/SD) - 3/8" I.D. for UL-60 (D/SD) - UL-150 (D/SD)

Air Inlet: N.P.T. 1/4

NOTE: Torque ranges reflect residual B joint torque values

All pulse tools ending in "D" include a 1/4" Hex quick-change bit holder.

*  logo indicates where ERGO-DRIVE sockets/extensions benefit tool operation.

OMEGA PULSE / ACRA-PULSE® SERIES

ULT-50C



ULT-70CH



OMEGA PULSE ULT SERIES ANGLE SHUT-OFF

MODEL	FREE SPEED rpm	TORQUE RANGE		WEIGHT		OVERALL LENGTH		DRIVE In	SOUND LEVEL db(a)	AIR USAGE cfm
		Nm	ft-lb	lb	kg	In	mm			
ULT-40C	3,500	4.5 - 7.5	3.3 - 5.6	2.9	1.30	9.8	250	3/8" Sq. Dr.	70	7.0
ULT-50C	4,500	7.0 - 15.5	5.2 - 11.5	3.0	1.35	9.8	250	3/8" Sq. Dr.	78	8.6
ULT-60C	5,200	13 - 28	9.6 - 20.7	3.2	1.45	10.3	261	3/8" Sq. Dr.	80	10.5
ULT-70C	4,400	20 - 35	14.8 - 25.9	3.6	1.65	10.8	275	3/8" Sq. Dr.	82	12.3
ULT-70CH	2,500	30 - 50	22.2 - 37.0	4.1	1.85	11.4	290	1/2" Sq. Dr.	82	12.3

"L" following model number denotes Low Air Pressure type
 "H" within model number denotes High Torque type

NOTE: Torque ranges reflect residual B joint torque values



UXR-T3000S



UX-T1400



UXR-T1820

ACRA-PULSE PISTOL SHUT-OFF 3/8" - 1/2" DRIVE

Recommended Air Pressure: 85 psi

MODEL	FREE SPEED RPM	TORQUE RANGE		OVERALL LENGTH		WEIGHT		FROM CENTER TO OUTSIDE		SQ. DRIVE IN	NOISE LEVEL DB(A)	AIR USAGE CFM
		NM	FT-LB	MM	IN	LB	KG	MM	IN			
UX-T700L*	7,500	13 - 26	10 - 19	187	7.4	3.2	1.5	25.5	1.0	3/8	72	10.5
UX-T700*	7,500	20 - 38	15 - 28	187	7.4	3.2	1.5	25.5	1.0	3/8	72	10.5
UX-T800	8,300	30 - 45	22 - 33	196	7.7	4.0	1.8	28.0	1.1	3/8	75	12.3
UX-T900	7,000	35 - 70	25 - 50	202	7.9	4.4	2.0	30.0	1.2	1/2	75	16.0
UX-T1000	6,800	50 - 90	36 - 65	207	8.2	5.2	2.4	33.0	1.3	1/2	75	17.6
UX-T1300	6,200	70 - 130	50 - 94	225	8.9	6.2	2.8	36.0	1.4	1/2	77	19.4
UX-T1400	5,300	100 - 160	75 - 115	245	9.6	7.5	3.4	40.0	1.6	1/2	79	21.1

Air Hose Size: 3/8 I.D.

Air Inlet: N.P.T. 1/4

NOTE: Torque ranges reflect residual B joint torque values

* UX-T700 and UX-T700L models can be equipped with TM (Tightening Monitor) feature for use with qualifier systems. Order TM tools by adding "TM" to model number (for example, UX-T700 becomes UX-T700TM).

ACRA-PULSE SHUT-OFF 3/4" - 1" DRIVE

Recommended Air Pressure: 85 psi

MODEL	FREE SPEED RPM	TORQUE RANGE		OVERALL LENGTH		WEIGHT		FROM CENTER TO OUTSIDE		SQ. DRIVE IN	NOISE LEVEL DB(A)	AIR USAGE CFM
		NM	FT-LB	MM	IN	LB	KG	MM	IN			
PISTOL												
UX-T1620	5,000	120 - 210	87 - 150	260	10.2	8.1	3.7	40.0	1.6	3/4	82	22.9
UXR-T1820	4,400	150 - 250	110 - 180	270	10.6	9.9	4.5	42.0	1.7	3/4	84	24.7
UXR-T2000	4,000	200 - 400	150 - 290	303	11.9	15.0	6.8	47.0	1.8	3/4	85	34.0
INLINE												
UXR-T2400S*	3,600	360 - 650	260 - 470	444	17.5	26.5	12.0	61.5	2.4	1	85	35.3
UXR-T3000S	4,400	450 - 850	330 - 620	477	18.8	32.0	14.5	62.0	2.4	1	85	37.1

Air Hose Size: 3/8" I.D. for UX-T1620 - 1/2" I.D. for UXR-T1820 - UXR-T3000S

Air Inlet: N.P.T. 3/8" for UXR-T1820 - UXR-T2000 - N.P.T. 1/2" for UXR-T2400S - UXR-T3000S - N.P.T. 1/4" for UX-T1620

NOTE: Torque ranges reflect residual B joint torque values

Inside Trigger Standard (UXR-T2400S - UXR-T3000S)

* UXR-T2400S model can be equipped with TM (Tightening Monitor) feature for use with qualifier systems. Order TM tools by adding "TM" to model number (UXR-T2400STM).

*  logo indicates where ERGO-DRIVE sockets/extensions benefit tool operation.

ACRA-PULSE® SERIES



UX-1400



Auto Reversing
UX-ST800

PISTOL NON SHUT-OFF 1/4" HEX DRIVE

Recommended Air Pressure: 85 psi

MODEL	FREE SPEED RPM	TORQUE RANGE		OVERALL LENGTH		WEIGHT		FROM CENTER TO OUTSIDE		NOISE LEVEL DB(A)	AIR USAGE CFM
		NM	FT-LB	MM	IN	LB	KG	MM	IN		
U-350D	10,500	3.5 - 5.8	2.5 - 4.2	154	6.1	1.7	0.8	22.0	0.9	74	5.3
UX-450D	9,500	8 - 14	5.8 - 10	152	6.0	1.9	0.9	22.0	0.9	<70	7.0
UX-500D	9,300	13 - 20	10 - 15	152	6.0	1.9	0.9	22.0	0.9	70	8.8
UX-612D	9,300	16 - 28	12 - 20	165	6.5	2.1	1.0	22.5	0.9	75	11.2

Air Hose Size: 1/4" I.D. for U-350D - UX-500D - 3/8" I.D. for UX-612D - UX-700D Air Inlet Thread: N.P.T. 1/4"
All Tools Standard with 1/4" Quick Change Chuck

NOTE: Torque ranges reflect residual B joint torque values

PISTOL NON SHUT-OFF 3/8" - 1/2" DRIVE

Recommended Air Pressure: 85 psi

MODEL	FREE SPEED RPM	TORQUE RANGE		OVERALL LENGTH		WEIGHT		FROM CENTER TO OUTSIDE		SQ. DRIVE IN	NOISE LEVEL DB(A)	AIR USAGE CFM
		NM	FT-LB	MM	IN	LB	KG	MM	IN			
UX-450	9,500	9 - 15	6.5 - 11	147	5.8	1.9	0.9	22.0	0.9	3/8	65	7.0
UX-500	9,300	15 - 25	11 - 19	147	5.8	1.9	0.9	22.0	0.9	3/8	70	8.8
UX-612	9,300	20 - 35	15 - 25	160	6.3	2.1	1.0	22.5	0.9	3/8	75	11.2
UX-700	9,000	25 - 45	20 - 35	169	6.7	3.0	1.4	25.5	1.0	3/8	73	12.3
UX-800	9,000	35 - 60	25 - 45	175	6.9	3.7	1.7	28.0	1.1	3/8	73	14.1
UX-900	7,600	45 - 75	35 - 55	181	7.1	4.1	1.9	30.0	1.2	1/2	75	14.7
UX-1000	6,800	50 - 95	40 - 70	187	7.4	4.8	2.2	33.0	1.3	1/2	75	17.9
UX-1300	6,200	80 - 130	60 - 95	205	8.1	5.9	2.7	36.0	1.4	1/2	76	19.4
UX-1400	5,300	100 - 160	75 - 120	224	8.8	7.0	3.2	40.0	1.6	1/2	78	21.1

Air Hose Size: 1/4" I.D. for U-410 - UX-500 - 3/8" I.D. for UX-612 - UX-1400

Air Inlet: N.P.T. 1/4"

NOTE: Torque ranges reflect residual B joint torque values

PISTOL NON SHUT-OFF 3/4" - 1" DRIVE

Recommended Air Pressure: 85 psi

MODEL	FREE SPEED RPM	TORQUE RANGE		OVERALL LENGTH		WEIGHT		FROM CENTER TO OUTSIDE		SQ. DRIVE IN	NOISE LEVEL DB(A)	AIR USAGE CFM
		NM	FT-LB	MM	IN	LB	KG	MM	IN			
UX-1620	5,000	120 - 190	90.0 - 140.0	241	9.5	7.9	3.6	40.0	1.6	3/4	82	22.9
UXR-1820	4,600	160 - 250	120.0 - 185.0	242	9.5	9.0	4.1	42.0	1.7	3/4	84	26.3
UXR-2000	4,200	300 - 450	220.0 - 330.0	282	11.1	14.3	6.5	47.0	1.8	3/4	85	31.5

Air Hose Size: 3/8" I.D. for UX-1620 1/2" I.D. for UXR-1820

Air Inlet: N.P.T. 1/4" for UX-1620 N.P.T. 3/8" for UXR-1820, UXR-2000

NOTE: Torque ranges reflect residual B joint torque values Torque Control in Left-Hand Rotation Available for UXR-2000

AUTO REVERSING

Recommended Air Pressure: 85 psi

MODEL	FREE SPEED RPM	TORQUE RANGE		OVERALL LENGTH		WEIGHT		FROM CENTER TO OUTSIDE		NOISE LEVEL DB(A)	AIR USAGE CFM
		NM	FT-LB	MM	IN	LB	KG	MM	IN		
UX-ST800	7,300	35 - 55	25 - 40	195	7.7	3.8	1.8	28.0	1.1	75	10.5

Air Hose Size: 3/8" I.D.

Air Inlet: N.P.T. 1/4"

NOTE: Torque ranges reflect residual B joint torque values

*  logo indicates where ERGO-DRIVE sockets/extensions benefit tool operation.

ACRA-PULSE® SERIES



UX-700S



U-410S



UX-700C

INLINE NON SHUT-OFF 1/4" HEX DRIVE

Recommended Air Pressure: 85 psi

MODEL	FREE SPEED RPM	TORQUE RANGE		OVERALL LENGTH		WEIGHT		FROM CENTER TO OUTSIDE		NOISE LEVEL DB(A)	AIR USAGE CFM
		NM	FT-LB	MM	IN	LB	KG	MM	IN		
U-310SD	11,000	2.5 - 3.1	1.8 - 2.2	222	8.7	1.5	0.6	18.0	0.7	74	5.3
U-350SD	10,500	3.5 - 5.8	2.5 - 4.2	238	9.4	1.5	0.7	22.0	0.7	74	5.3
U-410SD	10,500	7 - 10	5.0 - 7.2	240	9.5	1.8	0.8	22.0	0.9	70	5.3
UX-450SD	9,500	8 - 14	5.8 - 10	239	9.4	1.8	0.8	22.0	0.9	<70	7.0
UX-500SD	9,300	13 - 20	10 - 15	244	9.5	2.0	0.9	22.0	0.9	70	8.8
UX-612SD	9,300	16 - 28	12 - 20	253	10.0	2.2	1.0	23.3	0.9	75	11.1
UX-700SD	9,000	20 - 36	16 - 28	249	9.8	2.8	1.3	26.5	1.0	78	12.3

Air Hose Size: 1/4" I.D. for U-310SD - UX-500SD - 3/8" I.D. for UX-612D - UX-700SD Air Inlet: N.P.T. 1/4"
All Tools Standard with 1/4 Quick Change Chuck

NOTE: Torque ranges reflect residual B joint torque values

INLINE NON SHUT-OFF 3/8" - 1/2" DRIVE

Recommended Air Pressure: 85 psi

MODEL	FREE SPEED RPM	TORQUE RANGE		OVERALL LENGTH		WEIGHT		FROM CENTER TO OUTSIDE		SQ. DRIVE IN	NOISE LEVEL DB(A)	AIR USAGE CFM
		NM	FT-LB	MM	IN	LB	KG	MM	IN			
U-410S	10,500	7 - 10	5.0 - 7.2	239	9.4	1.8	0.8	22.0	0.9	3/8	70	5.3
UX-450S	9,500	9 - 15	6.5 - 11	234	9.2	1.8	0.8	22.0	0.9	3/8	<70	7.0
UX-500S	9,300	15 - 25	11 - 19	239	9.4	2.0	0.9	22.0	0.9	3/8	70	8.8
UX-612S	9,300	20 - 35	15 - 25	248	9.8	2.2	1.0	23.3	0.9	3/8	75	11.1
UX-700S	9,000	25 - 45	20 - 35	244	9.5	2.8	1.3	26.5	1.0	3/8	78	12.3
UX-800S	9,000	35 - 60	25 - 45	250	9.8	3.2	1.5	35.5	1.0	3/8	75	14.2
UX-900S	7,600	45 - 75	35 - 55	310	12.2	3.9	1.8	37.5	1.1	1/2	75	14.9
UX-1000S	6,800	50 - 95	40 - 70	320	12.6	4.6	2.1	39.0	1.1	1/2	75	17.9
UX-1300S	6,200	80 - 130	60 - 95	336	13.2	6.6	2.6	42.0	1.3	1/2	77	19.4

Air Hose Size: 1/4" I.D. for U-410S - UX-500S - 3/8" I.D. for UX-612S - UX-1300S

Air Inlet: N.P.T. 1/4"

NOTE: Torque ranges reflect residual B joint torque values

INLINE NON SHUT-OFF 3/4" - 1" DRIVE

Recommended Air Pressure: 85 psi

MODEL	FREE SPEED RPM	TORQUE RANGE		OVERALL LENGTH		WEIGHT		FROM CENTER TO OUTSIDE		SQ. DRIVE IN	NOISE LEVEL DB(A)	AIR USAGE CFM
		NM	FT-LB	MM	IN	LB	KG	MM	IN			
UXR-2000S	4,200	300 - 450	220 - 330	340	13.4	15.4	7.0	47.0	1.8	3/4	85	31.6
UXR-2400S	4,000	400 - 650	290 - 470	385	15.2	23.7	11.0	55.0	2.1	1	85	35.2
UXR-3000S	4,400	500 - 850	360 - 630	455	17.9	29.3	13.3	62.0	2.1	1	85	37.1
UXR-3000S(OUT)	4,400	500 - 850	360 - 630	455	17.9	29.3	13.3	62.0	2.1	1	85	37.1

UXR-2000 S - UXR-3000S have an inside trigger. UXR-3000S(OUT) has an outside trigger
Air Hose Size: 1/2" I.D.

Air Inlet (NPT): 3/8" for UXR-2000S 1/2" for UXR-2400S, UXR-3000S, and UXR-3000S(OUT)

NOTE: Torque ranges reflect residual B joint torque values
Torque control in left-hand rotation available

ANGLE 3/8" - 1/2" DRIVE

Recommended Air Pressure: 85 psi

MODEL	FREE SPEED RPM	TORQUE RANGE		WEIGHT		OVERALL LENGTH		SQ. DRIVE IN	NOISE LEVEL DB(A)	AIR USAGE CFM
		NM	FT-LB	LB	KG	MM	IN			
ALPHA-70C	6,300	28 - 45	20.2 - 32.5	3.9	1.8	266	10.5	3/8	82	15.8
ALPHA-70CH	3,600	50 - 76	36.1 - 56.0	4.4	2.0	282	11.1	1/2	82	15.8
UX-500C	9,300	13 - 20	10.0 - 15.0	2.8	1.3	270	10.6	3/8	82	8.8
UX-612C	9,800	16 - 28	12.0 - 20.0	3.0	1.4	283	11.1	3/8	85	11.2
UX-700C	9,500	20 - 36	16.0 - 28.0	3.7	1.7	273	10.8	3/8	85	12.3
UX-800C	9,000	29 - 43	20.0 - 31.0	4.3	1.9	285	11.2	3/8	85	14.1
UX-1000C	6,800	50 - 80	40.0 - 58.0	6.8	3.1	365	14.4	1/2	90	17.9

Air Hose Size: 1/4" I.D. for UX-500C - 3/8" I.D. for ALPHA-70C, ALPHA-70CH, UX-612C - UX-1000C

Air Inlet: N.P.T. 1/4"

NOTE: Torque ranges reflect residual B joint torque values

* E logo indicates where ERGO-DRIVE sockets/extensions benefit tool operation.

UDBP PULSE SERIES CORDLESS TOOLS

The next-generation cordless pulse tool combines industry-leading pulse technology with Lithium-Ion battery power.

FEATURES AND BENEFITS

- Uryu Direct Battery Pulse (UDBP) – This new design connects the pulse unit directly to the motor – no reduction gearing – resulting in a tool with less noise and vibration.
- Brushless Internal Permanent Magnet (IPM) motor provides longer motor life and more efficiency allowing more fastening cycles per battery charge.
- UDBP features patented Auto Relief Technology providing additional control to the application of torque during the pulsing events.
- On board LEDs for application illumination.
- Li-Ion battery provides more power and ends the “battery-memory” issues of NiCd batteries.
- Tool/battery combination is 27% lighter than earlier UBP tools.
- RF Types transmit “good” signal to receiver (sold separately) over 426Mhz.
- “Good” signal can be used for Poka-Yoke or Bolt Counting.



UDBP-TA50



Charger: UBC



The lithium-ion battery provides better power-to-weight ratio. It will not be affected by the memory effect caused by repeated recharging after being only partially discharged.

The battery power indicator provides you with a visual indication to charge the lithium-ion battery.

- = good charge
- = low charge (recharging needed)
- = very low charge (immediate recharging needed)

The slide design battery provides the high-energy efficiency in power and no damage to contact.

Battery: UB111Li, UB222Li, UB333Li

(P) represents the 3/8" square drive anvil with socket retainer pin. (RF) represents the tool with wireless transmission feature.

MODEL	TYPE	FREE SPEED RPM	TORQUE RANGE Nm	ft-lb	WEIGHT W/BATTERY lb	LENGTH in	DRIVE in	SOUND LEVEL dB(A)	VOLTAGE V	BATTERY	CHARGER
UDBP-TA40	Shut-off	4,800	4.5 - 8	3.3 - 5.9	3.1	8.2	1/4 hex	75	11.1	UB111Li	UBC
UDBP-TA40(P)(RF)	Shut-off	4,800	4.5 - 8	3.3 - 5.9	3.1	8.2	1/4 hex	75	11.1	UB111Li	UBC
UDBP-TA50	Shut-off	4,800	6.5 -13	4.8 - 9.6	3.1	8.2	1/4 hex	76	11.1	UB111Li	UBC
UDBP-TA50(RF)	Shut-off	4,800	6.5 -13	4.8 - 9.6	3.1	8.2	1/4 hex	76	11.1	UB111Li	UBC
UDBP-TA60	Shut-off	4,800	13 - 26	9.6 - 19.2	3.7	8.8	1/4 hex	77	22.2	UB222Li	UBC
UDBP-TA60(RF)	Shut-off	4,800	13 - 26	9.6 - 19.2	3.7	8.8	1/4 hex	77	22.2	UB222Li	UBC
UDBP-TA50(P)	Shut-off	4,800	7 - 15	5.1 - 11.1	3.1	8.1	3/8 sq.	76	11.1	UB111Li	UBC
UDBP-TA50(P)(RF)	Shut-off	4,800	7 - 15	5.1 - 11.1	3.1	8.1	3/8 sq.	76	11.1	UB111Li	UBC
UDBP-TA60(P)	Shut-off	4,800	15 - 28	11.1 - 20.7	3.7	8.7	3/8 sq.	76	22.2	UB222Li	UBC
UDBP-TA60(P)(RF)	Shut-off	4,800	15 - 28	11.1 - 20.7	3.7	8.7	3/8 sq.	76	22.2	UB222Li	UBC
UDBP-TA70(P)(RF)	Shut-off	4,800	26 - 47	19.2 - 34.7	4.4	9.2	3/8 sq.	76	33.3	UB333Li	UBC

Adding "KIT" to the tool model number will include two (2) batteries and the battery charger with the specified tool. Example: UDBP-T50KIT

NOTE: Torque ranges reflect residual B joint torque values.

Battery: UB111Li, UB222Li, UB333Li (also sold separately)

Charger: UBC (also sold separately)

Charge Time: 80% battery capacity - 40 minutes, 100% battery capacity - 64 minutes.

BODY JACKETS FOR UDBP SERIES

MODEL	DESCRIPTION
863-964-1	UDBP TOOL, 40/50 SERIES
863-965-1	UDBP TOOL, 60 SERIES
863-966-1	UDBP TOOL, 70 SERIES

BATTERY COVERS

MODEL	DESCRIPTION
863-976-1	UDBP BATTERY COVER, 40/50 SERIES
863-977-1	UDBP BATTERY COVER, 60 SERIES
863-978-1	UDBP BATTERY COVER, 70 SERIES

RECEIVER



MODEL	DESCRIPTION
TWF-600R	Receiver for UDBP (RF) type tools 426Mhz (also sold separately)

* ERGO logo indicates where ERGO-DRIVE sockets/extensions benefit tool operation.

UDBP PULSE TOOL BATTERIES

UDBP SERIES KITS AND COMPONENTS

Standard Shut Off Type

TOOL	TOOL BATTERY (SUPPLIED SEPARATELY)	CHARGER	TOOL PLUS 1 BATTERY	TOOL PLUS 2 BATTERIES AND 1 CHARGER
UDBP-TA40	UB111LI	UBC	UDBP-TA40-B	UDBP-TA40-KIT
UDBP-TA50	UB111LI	UBC	UDBP-TA50-B	UDBP-TA50-KIT
UDBP-TA50(P)	UB111LI	UBC	UDBP-TA50(P)-B	UDBP-TA50(P)-KIT
UDBP-TA60	UB-222LI	UBC	UDBP-TA60-B	UDBP-TA60-KIT
UDBP-TA60(P)	UB-222LI	UBC	UDBP-TA60(P)-B	UDBP-TA60(P)-KIT
UDBP-TA70(P)	UB-333LI	UBC	UDBP-TA70(P)-B	UDBP-TA70(P)-KIT

Shut Off Type With Rf Communication (Poka Yoke)

TOOL	2 CHANNEL RF RECEIVER	TOOL BATTERY (SUPPLIED SEPARATELY)	CHARGER	TOOL PLUS 1 BATTERY	TOOL PLUS 2 BATTERIES AND 1 CHARGER
UDBP-TA40RF	TWF-600R	UB111LI	UBC	UDBP-TA40RF-B	UDBP-TA40RF-KIT
UDBP-TA50RF	TWF-600R	UB111LI	UBC	UDBP-TA50RF-B	UDBP-TA50RF-KIT
UDBP-TA50(P)RF	TWF-600R	UB111LI	UBC	UDBP-TA50(P)-RF-B	UDBP-TA50(P)-RF-KIT
UDBP-TA60RF	TWF-600R	UB-222LI	UBC	UDBP-TA60RF-B	UDBP-TA60RF-KIT
UDBP-TA60(P)RF	TWF-600R	UB-222LI	UBC	UDBP-TA60(P)-RF-B	UDBP-TA60(P)-RF-KIT
UDBP-TA70(P)RF	TWF-600R	UB-333LI	UBC	UDBP-TA70(P)-RF-B	UDBP-TA70(P)-RF-KIT

www.aimco-global.com

800-852-1368



UDP-TA SERIES

DIRECT PLUG IN, SHUT OFF PULSE TOOLS

FEATURES AND BENEFITS

- Direct Wall Plug in – Tool plugs directly to 100 – 115VAC wall power with circuit protection breaker box or integrated power cable balancer.
- Brushless (IPM) Motor provides long motor life with integrated trigger activated fan for increased duty cycle.
- Patented Auto Relief Pulse Unit Technology.
- Lightweight, high impact, rugged plastic housing for superior ergonomics.
- Optional power cable integrated balancer available.



UDP-TA SERIES

MODEL	TORQUE RANGE		RPM FREE SPEED	OVERALL LENGTH		WEIGHT		DRIVE
	NM	FT LBS		IN	MM	LB	KG	
Bottom Cable Exit Models (denoted by -B)								
UDP-TA40-B	4.5 - 8.0	3.3 - 5.9	3,300	7.1	179.5	3.0	1.4	3/8" Sq.
UDP-TA40D-B	4.5 - 8.0	3.3 - 5.9	3,300	7.2	182.5	3.0	1.4	1/4" Hex
UDP-TA50-B	7.0 - 15.5	5.2 - 11.5	3,900	7.1	179.5	3.0	1.4	3/8 Sq.
UDP-TA50D-B	7.0 - 15.5	5.2 - 11.5	3,900	7.2	182.5	3.0	1.4	1/4" Hex
UDP-TA55-B	12.5 - 25.0	9.3 - 18.5	4,800	7.3	184.5	3.0	1.4	3/8" Sq.

Top Cable Exit Models (denoted by (B-TL))

UDP-TA40 (B-TL)	4.5 - 8.0	3.3 - 5.9	3,300	7.1	179.5	3.0	1.4	3/8" Sq.
UDP-TA40D (B-TL)	4.5 - 8.0	3.3 - 5.9	3,300	7.2	182.5	3.0	1.4	1/4" Hex
UDP-TA50 (B-TL)	7.0 - 15.5	5.2 - 11.5	3,900	7.1	179.5	3.0	1.4	3/8" Sq.
UDP-TA50D (B-TL)	7.0 - 15.5	5.2 - 11.5	3,900	7.2	182.5	3.0	1.4	1/4" Hex
UDP-TA55 (B-TL)	12.5 - 25.0	9.3 - 18.5	4,800	7.3	184.5	3.0	1.4	3/8" Sq.

OPTIONAL ACCESSORIES

MODEL	DESCRIPTION
UCB-25	Power Cable Balancer
910-629-0	Breaker Unit
910-618-0	5M UDP Tool to Breaker Cable
910-619-0	10M UDP Tool to Breaker Cable
910-627-0	5M UDP Extension Cable*

* Extension Cables connect between Tool and Breaker Cables



UCB-25
Power Cable
Balancer



910-629-0

NUTRUNNERS: OVERVIEW

UAN SERIES ANGLE NUTRUNNERS

- Torque Control
- Electronically Monitored or Controlled Type

Designed for fastening in tight quarters or applications not served well by a pulse tool. The UAN Series transfers torque through beveled angle gears, continuously driving the fastener. When the resistance to rotation overcomes the spring resistance on the clutch, the tool will disengage at the adjusted torque value. Low reaction force characteristics on hard joints make it comfortable for the operator to use. Ideal for applications ranging from 6-60 Nm (4 – 44 ft-lbs).

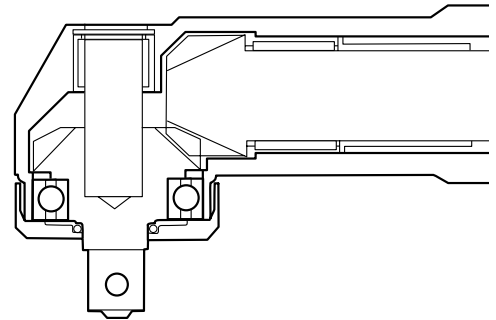

URW SERIES IN-LINE RATCHET WRENCHES

Designed to set flush over the fastener head, the URW Series is ideal for narrow fastening spaces. Motor torque is transferred from a gear driven, dual lobed cam that pushes a spring loaded push rod, rotating the socket one tooth at a time. A wide variety of socket sizes, head thicknesses, and tool lengths allow the URW Series access to many difficult applications.

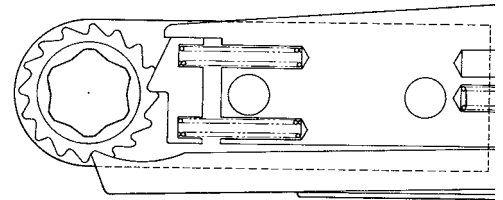

UOW SERIES OPEN-END NUTRUNNERS

Designed for tubenut fastening, the UOW Series can transfer torque through a variety of options.

- Stall Type – Depending on the application requirements, the standard UOW Series will stall when torque resistance matches power output.
- Mechanical Shut-off Type – For greater torque accuracy and less reaction impulse to the operator, the UOW-T Series incorporates a mechanical clutch to shut off the tool at the preset torque.
- Electronically Monitored Type – For critical torque applications requiring monitoring or controlling of the fastening torque, the UOW-M Series utilizes a transducer to signal the clutch shut-off.
- UOW series incorporates a one-hand, two-step throttle, which automatically reverses the socket to a preset open position.

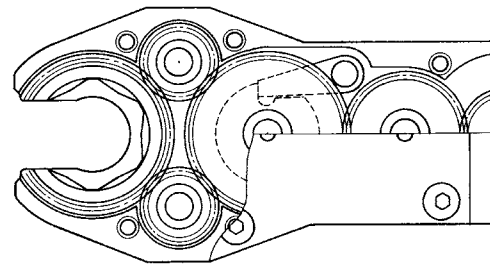

NUTRUNNERS



UAN-611R-30C

ANGLE TORQUE CONTROL UAN SERIES

Recommended Air Pressure: 85 psi

MODEL	TORQUE RANGE		FREE SPEED RPM	OVERALL LENGTH		ANGLE HEAD HEIGHT		FROM CENTER TO OUTSIDE		WEIGHT LESS SOCKET		SQUARE DRIVE IN	NOISE LEVEL DB(A)	AIR USAGE CFM
	NM	FT-LB		MM	IN	MM	IN	MM	IN	KG	LB			
UAN-611R-60C	6.5 - 12.0	4.3 - 8.6	620	383	15.1	47	1.9	14.0	0.5	1.6	3.5	3/8	80	21.2
UAN-611R-50C	8.5 - 15.0	5.7 - 10.8	470	373	14.7	47	1.9	14.0	0.5	1.6	3.5	3/8	80	21.2
UAN-611R-40C	10.0 - 18.0	7.2 - 12.9	400	373	14.7	47	1.9	14.0	0.5	1.6	3.5	3/8	80	21.2
UAN-611R-30C	13.0 - 25.0	9.3 - 18.0	270	373	14.7	47	1.9	14.0	0.5	1.6	3.5	3/8	80	21.2
UAN-701R-60C	20.0 - 31.0	14.5 - 23.1	600	445	17.5	47	1.9	14.0	0.5	2.4	5.3	3/8	85	31.8
UAN-701R-40C	28.0 - 45.0	21.0 - 33.3	400	455	17.9	51	2.0	18.0	0.7	2.4	5.3	3/8	85	31.8
UAN-701R-30C	37.0 - 60.0	27.5 - 44.1	300	455	17.9	58	2.3	18.0	0.7	2.4	5.3	1/2	85	31.8

Air Hose Size: 3/8 I.D.

Air Inlet: N.P.T. 1/4



UOW-11-14

UOW/UOW-T SERIES TUBENUT WRENCHES

Recommended Air Pressure: 85 psi

MODEL	MAX TORQUE/RANGE		FREE SPEED RPM	OVERALL LENGTH		WEIGHT		MIN/MAX HEX SOCKET SIZE		NOISE LEVEL DB(A)	AIR USAGE CFM
	NM	FT-LB		MM	IN	LB	KG	MM	IN		
STALL											
UOW-11-10	13	9.6	390	295	11.7	3.3	1.5	7 - 12	1/4 - 7/16	76	10.5
UOW-11-14	16	11.8	290	311	12.3	3.5	1.6	10 - 17	7/16 - 5/8	76	10.5
UOW-11-22	24	17.8	220	326	12.8	3.9	1.8	11 - 24	7/16 - 5/8	76	10.5
UOW-11-30	32	23.7	160	347	13.7	4.4	2.0	14 - 36	5/8 - 1-3/16	76	10.5
SHUT-OFF CLUTCH											
UOW-T60-10	4 - 14	3.0 - 10.4	300	370	14.6	4.6	2.1	7 - 12	1/4 - 7/16	76	10.5
UOW-T60-14	5 - 17	3.7 - 12.6	240	385	15.1	4.9	2.2	10 - 17	7/16 - 5/8	76	10.5
UOW-T60-22	7 - 24	5.2 - 17.8	170	400	15.8	5.2	2.4	11 - 24	7/16 - 5/8	76	10.5
UOW-T60-30	10 - 32	7.4 - 23.7	130	420	16.6	5.7	2.6	14 - 36	5/8 - 1-3/16	76	10.5
GEARED WRENCHES											
UGW-6N	18	13.3	530	310	12.2	3.1	1.4	9 - 12	3/8 - 7/16	76	10.5
UGW-8N	23	17.0	410	322	12.7	3.2	1.5	10 - 17	7/16 - 5/8	76	10.5

Air Hose Size: 3/8 I.D.

Air Inlet: N.P.T. 1/4

*  logo indicates where ERGO-DRIVE sockets/extensions benefit tool operation.

NUTRUNNERS



URW-8

URW SERIES RATCHET WRENCHES

Recommended Air Pressure: 85 psi

MODEL	MAX TORQUE		FREE SPEED	OVERALL LENGTH		WEIGHT		MIN/MAX HEX SOCKET SIZE		AIR USAGE
	Nm	ft-lb	rpm	mm	in	lb	kg	mm	in	cfm
STRAIGHT HEAD										
URW-6	11	8.1	210	292	11.5	2.5	1.2	6 - 12	1/4 - 7/16	9.9
URW-8N	16	11.8	260	300	11.8	4.2	1.9	7 - 15	7/16 - 9/16	19.5
URW-8	16	11.8	240	360	14.2	5.0	2.3	7 - 15	7/16 - 9/16	19.8
URW-9N	31	22.9	140	380	15.0	5.2	2.4	7 - 15	7/16 - 9/16	23.7
URW-10N	57	42.2	155	394	15.5	5.8	2.7	10 - 19	9/16 - 3/4	25.0
URW-12N	59	43.7	145	397	15.6	5.9	2.7	12 - 23	3/8 - 13/16	25.0
URW-12NA	78	57.7	105	408	16.1	6.2	2.8	17 - 27	11/16 - 15/16	25.0
URW-12NB	93	68.8	90	416	16.3	6.4	2.9	24 - 32	5/8 - 1-1/8	25.0
BENT HEAD										
URW-60R*	11	8.1	210	288	11.3	2.5	1.2	6 - 12	1/4 - 7/16	9.9
URW-60*	11	8.1	210	288	11.3	2.5	1.2	6 - 12	1/4 - 7/16	9.9
URW-80R*	16	11.8	240	300	11.8	5.0	2.3	7 - 15	7/16 - 9/16	19.5
URW-80*	16	11.8	240	300	11.8	5.0	2.3	7 - 15	7/16 - 9/16	19.5
URW-81**	16	11.8	240	300	11.8	5.0	2.3	7 - 15	7/16 - 9/16	19.5
URW-81R**	16	11.8	240	300	11.8	5.0	2.3	7 - 15	7/16 - 9/16	19.5

Air Hose Size: 3/8 I.D.

Air Inlet: N.P.T. 1/4

* 160° Bent Head

** 150° Bent Head



DYNATORQUE MANUAL TORQUE MULTIPLIERS

FEATURES AND BENEFITS

Manual Torque Multipliers offer the perfect, economical solution to high torque bolting applications.

- Superior power to weight ratio.
- Delivered torque accuracy +/- 4%.
- Anti-Wind Up feature (2,800 NM models and up).
- True Torque Multiplication Ratios.
- Standard Reaction Arms supplied. Custom reaction arms/nose extensions available to suit specific applications.
- Replaces long lever arms and/or slugging wrenches.
- Manually powered – no external power source required.
- Value priced.
- No preventative maintenance required.
- Overload protected by Shear Drive design.



ANTI-WIND UP FEATURE

Standard on models delivering 2,800 NM and up.

- Eliminates the backward force on the torque input device.
- Insures safe operation by the operator by not allowing the input device to spring backward when released.
- Eliminates the need to continually rotate the input device in 360 degree movements to apply torque. In many applications this is simply not possible.
- Facilitates removal of the multiplier from the application upon completion of the job.

SHEAR-OFF SYSTEM

In order to protect the gear system against overload, DynaTorque Multipliers are fitted with a controlled shear-off system (spare torsion shaft included). Sheared off pins can easily be replaced at the work site.

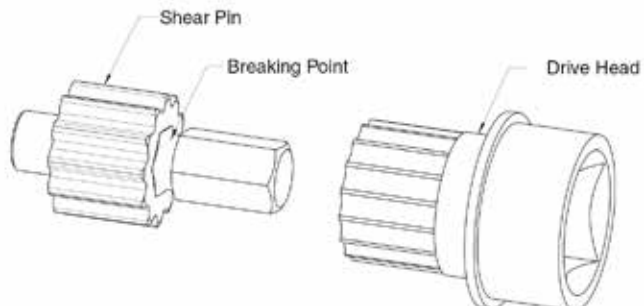

DYNATORQUE MANUAL TORQUE MULTIPLIERS

SPECIFICATIONS

MODEL	INPUT	OUTPUT	RATIO	MAX TORQUE OUTPUT	
	in	in		ft-lb	Nm
ATM-800	1/2	3/4	1:3.5	590	800
ATM-1800	3/4	1	1:3.6	1238	1800
ATM-2800	1/2	1	1:13	2066	2800
ATM-3800	3/4	1	1:13	2804	3800
ATM-5000	3/4	1.5	1:17	3690	5000
ATM-8000	3/4	1.5	1:49	5904	8000
ATM-12000	3/4	1.5	1:58	8856	12000
ATM-16000	3/4	2.5	1:75	11808	16000

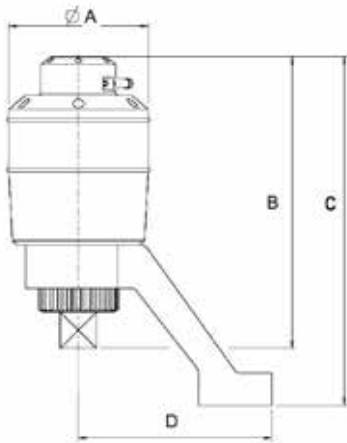

DIMENSIONS

	A	B	C	D	WEIGHT*	
	(MM)	(MM)	(MM)	(MM)	LB	KG
ATM-800	65	105	132	130	2.9	1.3
ATM-1800	90	150	188	132	6.6	3.0
ATM-2800	95	200	240	132	11.5	5.2
ATM-3800	95	200	240	132	11.5	5.2
ATM-5000	120	215	272	150	15.4	7.0
ATM-8000	132	268	344	200	25.4	11.5
ATM-12000	156	272	348	200	30.9	14.0
ATM-16000	215	292	370	225	57.3	26.0

* Weight shown does not include weight of reaction device.

ACCESSORIES

CARRYING CASE

All DynaTorque Multipliers are supplied in a rugged, weather-resistant, portable carrying case.



SCREWDRIVERS: OVERVIEW

TORQUE CONTROL AUTOMATIC SHUT-OFF TYPE

- Precise repeatability improves quality.
- Minimal wear on internal parts for longer life.
- Quick shut off for minimum torque reaction.
- Speed choice for flexibility.
- Easy external torque adjustment.
- Midrange air motor provides high speed during entire cycle.
- Ideal for industrial torque control applications.



CUSHION CLUTCH TYPE

- Good general duty screwdriver.
- High speed rundown.
- Clutch ratchets at preset torque.
- Internal torque adjustment.
- General assembly, wood, and sheet metal screws.

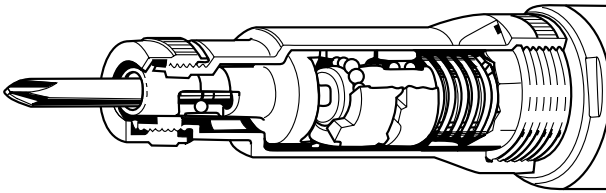

POSITIVE CLUTCH TYPE

- Good for varying torque applications.
- Clutch ratchets at preset torque.
- Operator can force clutch engagement for higher torque.
- Good for prevailing torque applications.

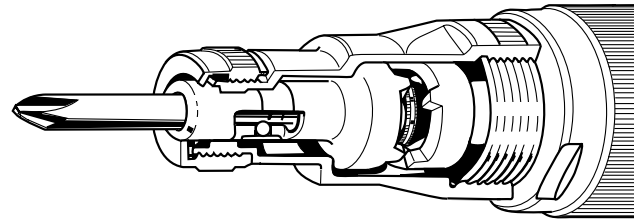

IMPACT TYPE

- High power-to-weight ratio.
- Fast cycle times with free speeds up to 16,000 rpm.
- Ideal for non-critical applications.

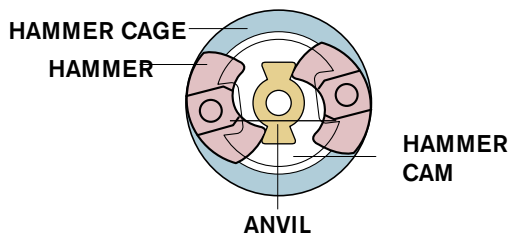

DIRECT DRIVE

- Air motor driven gears.
- Stall torque dependent on air pressure.
- Simple maintenance.
- Lightest and smallest air screwdriver.
- Ideal for soft draw applications such as wood screws, self tapping screws, or trim screws.

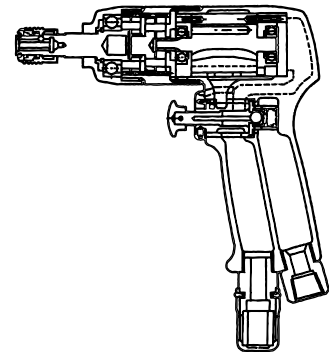

PNEUMATIC SCREWDRIVERS

TORQUE CONTROL LIGHT TOUCH (LT) SERIES - PUSH-TO-START INLINE

Recommended Air Pressure: 85 psi

MODEL	TORQUE RANGE		FREE SPEED rpm	OVERALL LENGTH		WEIGHT		FROM CENTER TO OUTSIDE		NOISE LEVEL dB(A)	AIR USAGE cfm
	Nm	in-lb		mm	in	lb	kg	mm	in		
US-LT10B	0.2 - 0.6	1.8 - 5.3	1,000	191	7.5	0.6	0.3	12.0	0.5	75	5.2
US-LT20B-10	0.4 - 1.1	3.1 - 9.7	1,000	180	7.1	0.7	0.3	13.0	0.5	70	5.6
US-LT20B-18	0.3 - 0.7	2.2 - 6.2	1,800	180	7.1	0.7	0.3	13.0	0.5	70	5.6
US-LT20B-26	0.2 - 0.4	1.3 - 3.1	2,600	180	7.1	0.7	0.3	13.0	0.5	71	5.6
US-LT30B-11	1.1 - 2.1	9.7 - 18.5	1,100	187	7.4	0.9	0.4	15.5	0.6	70	7.0
US-LT30B-17	0.7 - 1.5	6.2 - 13.2	1,700	187	7.4	0.9	0.4	15.5	0.6	70	7.0
US-LT30B-23	0.4 - 1.0	3.5 - 8.8	2,300	187	7.4	0.9	0.4	15.5	0.6	71	7.0
US-LT40B-08	1.6 - 4.0	14.1 - 35.2	800	209	8.2	1.4	0.7	16.5	0.6	70	10.5
US-LT40B-15	1.0 - 2.2	6.2 - 19.4	1,500	209	8.2	1.4	0.7	16.5	0.6	70	10.5
US-LT40B-21	1.0 - 1.7	6.2 - 15.0	2,100	209	8.2	1.4	0.7	16.5	0.6	74	10.5
US-LT50B-05	5.0 - 10.2	44.0 - 92.4	480	240	9.5	2.2	1.0	19.5	0.8	74	17.5
US-LT50B-08	3.0 - 5.5	26.4 - 48.4	800	240	9.5	2.2	1.0	19.5	0.8	75	17.5
US-LT50B-17	1.5 - 2.6	9.7 - 23.0	1,700	240	9.5	2.2	1.0	19.5	0.8	75	17.5

Air Hose Size: 1/4 I.D. for US-LT10B - US-LT40B Series - 3/8" I.D. for US-LT50B Series
Each model is equipped with its standard and alternate clutch springs

Air Inlet: 1/8 for US-LT10B - US-LT20B Series - 1/4" for US-LT30B - US-LT50B Series

TORQUE CONTROL LIGHT TOUCH (LT) SERIES - ANGLE AND LEVER

Recommended Air Pressure: 85 psi

MODEL	TORQUE RANGE SOFT JOINT		FREE SPEED rpm	OVERALL LENGTH		WEIGHT		FROM CENTER TO OUTSIDE		HEX BIT OR DRIVE SIZE	NOISE LEVEL dB(A)	AIR USAGE cfm
	Nm	in-lb		mm	in	lb	kg	mm	in			
ANGLE												
US-LT30B-11C	1.1 - 2.1	3.5 - 18.5	1,100	298	10.7	1.5	0.7	10	0.4	1/4	73	7.0
US-LT30B-17C	0.7 - 1.5	3.5 - 13.2	1,700	295	10.7	1.5	0.7	10	0.4	1/4	73	7.0
US-LT40B-05C	2.3 - 5.7	20.0 - 49.5	500	322	13.0	2.1	0.9	13	0.5	1/4	75	10.5
US-LT40B-08C	1.6 - 4.0	8.7 - 34.7	800	320	12.8	2.0	0.9	10	0.4	1/4	75	10.5
US-LT40B-15C	1.0 - 2.2	8.7 - 19.4	1,500	320	12.8	2.0	0.9	10	0.4	1/4	75	10.5
US-LT40-03C	5.0 - 10.0	43.4 - 86.8	300	360	14.2	2.4	1.1	13	0.5	1/4 Sq.	72	10.5
US-LT40-05C	2.3 - 5.7	20.0 - 50.2	500	322	13.0	2.1	0.9	13	0.5	1/4 Sq.	75	10.5
US-LT40-08C	1.6 - 4.0	8.7 - 34.7	800	320	12.8	2.0	0.9	10	0.4	1/4 Sq.	75	10.5
US-LT40-15C	0.98 - 2.06	8.7 - 18.2	1,500	320	12.8	2.0	0.9	10	0.4	1/4 Sq.	75	10.5
LEVER												
US-LT30BL-11	1.1 - 2.1	9.7 - 18.5	1,100	229	8.2	1.2	0.5	15	0.6	1/4	70	5.2
US-LT30BL-17	0.7 - 1.5	6.2 - 13.2	1,700	229	8.2	1.2	0.5	15	0.6	1/4	70	5.2
US-LT30BL-23	0.4 - 1.0	3.5 - 8.8	2,300	229	8.2	1.2	0.5	15	0.6	1/4	71	5.2
US-LT40BL-08	1.6 - 4.0	14.1 - 35.2	800	249	9.8	1.5	0.7	17	0.7	1/4	70	5.6
US-LT40BL-15	1.0 - 2.2	8.8 - 19.4	1,500	249	9.8	1.5	0.7	17	0.7	1/4	70	5.6
US-LT40BL-21	1.0 - 1.7	8.8 - 15.0	2,100	249	9.8	1.5	0.7	17	0.7	1/4	74	5.6

Angle Head Height: 32 - 36mm

Air Inlet: N.P.T. 1/4"

Air Hose Size: 1/4" I.D. for all models

TORQUE CONTROL LIGHT TOUCH (LT) SERIES - PISTOL

Recommended Air Pressure: 85 psi

MODEL	TORQUE RANGE (SOFT JOINT)		FREE SPEED rpm	OVERALL LENGTH		WEIGHT		FROM CENTER TO OUTSIDE		NOISE LEVEL dB(A)	AIR USAGE cfm
	Nm	in-lb		mm	in	lb	kg	mm	in		
US-LT31PB-05	2.4 - 5.0	21.1 - 44.0	500	189	8.2	1.9	0.9	16	0.6	70	7.0
US-LT31PB-11	1.1 - 2.1	9.7 - 18.5	1,100	170	7.0	1.6	0.7	16	0.6	70	7.0
US-LT31PB-17	0.7 - 1.5	6.2 - 13.2	1,700	170	7.0	1.6	0.7	16	0.6	70	7.0
US-LT31PB-23	0.4 - 1.0	3.5 - 8.8	2,300	170	7.0	1.6	0.7	16	0.6	70	7.0
US-LT41PB-08	1.6 - 4.0	14.0 - 35.2	800	175	7.7	1.9	0.9	17	0.6	70	10.5
US-LT41PB-15	1.0 - 2.2	8.8 - 19.4	1,500	175	7.7	1.9	0.9	17	0.6	70	10.5
US-LT41PB-21	1.0 - 1.7	8.8 - 15.0	2,500	175	7.7	1.9	0.9	17	0.6	74	10.5
US-LT51PB-05	5.0 - 10.5	44.0 - 92.4	480	198	8.5	2.6	1.2	20	0.8	74	17.5
US-LT51PB-08	3.0 - 5.5	26.4 - 48.4	800	198	8.5	2.6	1.2	20	0.8	75	17.5
US-LT51PB-17	1.5 - 2.6	13.2 - 22.9	1,700	198	8.5	2.6	1.2	20	0.8	75	17.5
US-LT60P-03*	7.0 - 20.0	61.6 - 176.0	320	230	9.1	3.7	1.7	22	0.9	75	21.0
US-LT60P-07*	4.0 - 10.0	35.2 - 88.0	650	230	9.1	3.7	1.7	22	0.9	76	21.0
US-LT60P-11*	4.0 - 7.0	35.2 - 61.6	1,100	230	9.1	3.7	1.7	22	0.9	77	21.0

Air Hose Size: 1/4 I.D. for US-LT31PB & US-LT41PB Series

Air Inlet: N.P.T. 1/4"

3/8 I.D. for US-LT31PB-05, US-LT51PB Series & US-LT60P Series

* Optional 3/8" Sq. Drive available for US-LT60P Series ADD (P) to Model Number

PNEUMATIC SCREWDRIVERS



US-LT Series Model

OPTIONAL CLUTCH SPRINGS

MODEL	CLUTCH SPRINGS PROVIDED		RECOMMENDED TORQUE RANGE HARD JOINT		CLUTCH SPRING CODE NUMBER
	Standard	Option	Nm	in-lb	
US-LT10B	Black		0.20 - 0.60	1.7 - 5.2	976-379-0
US-LT20B-10	Black		0.34 - 1.10	3.0 - 9.5	976-432-0
		Red	0.20 - 0.70	1.7 - 6.1	976-431-0
		Yellow	0.15 - 0.34	1.3 - 3.0	976-430-0
US-LT20B-18	Red		0.24 - 0.67	2.2 - 6.1	976-431-0
		Yellow	0.15 - 0.34	1.3 - 3.0	976-430-0
US-LT20B-26	Yellow		0.15 - 0.34	1.3 - 3.0	976-430-0
US-LT31PB-05	Red		2.35 - 5.00	20.9 - 44.0	976-493-0
		Pink	0.98 - 2.74	8.7 - 24.3	976-471-0
US-LT30 Series, 1100 rpm	Blue		0.98 - 2.1	8.7 - 18.5	976-472-0
		Red	0.67 - 1.76	6.1 - 15.6	976-493-0
		Pink	0.39 - 0.98	3.5 - 8.7	976-471-0
		Black (not included)	1.22 - 2.74	10.8 - 24.3	976-504-0
US-LT30 Series, 1700 rpm	Red		0.67 - 1.47	6.1 - 13.0	976-493-0
		Pink	0.39 - 0.98	3.5 - 8.7	976-471-0
US-LT30 Series, 2300 rpm	Pink		0.39 - 0.98	3.5 - 8.7	976-471-0
US-LT40-03C	Red		4.90 - 9.80	43.4 - 86.8	976-516-0
US-LT40 Series, 800 rpm	Black		1.57 - 3.92	13.9 - 34.7	976-515-0
		Red	0.98 - 2.17	8.7 - 19.1	976-516-0
		Yellow	0.98 - 1.67	8.7 - 14.8	976-517-0
US-LT40 Series, 1500 rpm	Red		0.98 - 2.17	8.7 - 19.1	976-516-0
		Yellow	0.98 - 1.67	8.7 - 14.8	976-517-0
US-LT40 Series, 2100 rpm	Yellow		0.98 - 1.67	8.7 - 14.8	976-517-0
US-LT50 Series, 500 rpm	Black		4.9 - 10.3	43.4 - 91.1	976-620-0
		Red	2.9 - 5.4	26.1 - 47.7	976-614-0
		Yellow	1.4 - 2.5	13.0 - 22.6	976-588-0
US-LT50 Series, 800 rpm	Red		2.7 - 5.4	24.3 - 47.7	976-614-0
US-LT50 Series, 1700 rpm	Yellow		1.4 - 2.5	13.0 - 22.6	976-588-0
		Yellow	1.4 - 2.6	13.0 - 23.0	976-588-0

EXTERNAL TORQUE ADJUSTMENT (AIR SHUT-OFF)

Set the hand driver into the key hole on the Adjusting Gear, turn clockwise to increase torque. Turn counter clockwise to decrease torque.

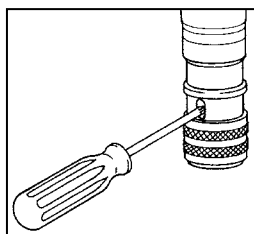

SILENCER ASSEMBLIES

MODEL	DIRECT TYPE SILENCER	LEADER HOSE ASSEMBLY	EXHAUST HOSE ASSEMBLY
US-LT10 Series	N/A	934-201-0	459-885-1
US-LT20 Series	455-088-2	934-201-0	455-885-1
US-LT30 Series	408-088-2	934-150-0	408-885-0
US-LT40 Series	496-088-1	934-150-0	496-885-1

PNEUMATIC SCREWDRIVERS



US-LD40P-15

DIRECT DRIVE SERIES

Recommended Air Pressure: 72 psi

MODEL	SOFT JOINT		HARD JOINT		FREE SPEED rpm	OVERALL LENGTH		WEIGHT		FROM CENTER TO OUTSIDE		NOISE LEVEL db(A)	AIR USAGE cfm
	Nm	ft-lb	Nm	ft-lb		mm	in	lb	kg	mm	in		
PISTOL													
US-LD40P-08	4.8	3.6	5.7	4.2	940	130	5.1	1.5	0.7	17	0.7	70	14.0
US-LD40P-15	3.0	2.2	3.2	2.4	1,700	130	5.1	1.5	0.7	17	0.7	70	14.0
US-LD40P-21	2.0	1.5	2.8	2.1	2,500	130	5.1	1.5	0.7	17	0.7	74	14.0
US-LD50P-05	10.0	7.4	11.2	8.3	500	153	6.0	2.0	0.9	20	0.8	74	17.5
US-LD50P-08	6.5	4.8	7.8	5.8	900	153	6.0	2.0	0.9	20	0.8	75	17.5
US-LD50P-17	3.5	2.6	5.9	4.4	1,900	150	5.9	2.0	0.9	20	0.8	75	17.5
ANGLE	CAPACITY (SCREW SIZE)		FREE SPEED rpm	OVERALL LENGTH		WEIGHT		FROM CENTER TO OUTSIDE		NOISE LEVEL db(A)	AIR USAGE cfm		
	mm	in		mm	in	lb	kg	mm	in				
US-3.5ACB	4	No. 8	2,000	200	7.9	1.4	0.7	10.0	0.4	85	7.0		

Air Hose Size: 1/4" I.D.

Air Inlet: N.P.T. 1/4"



US-3.5PB

CUSHION CLUTCH SERIES

Recommended Air Pressure: 57 psi

MODEL	CAPACITY (SCREW SIZE)		FREE SPEED rpm	OVERALL LENGTH		WEIGHT LESS BIT		FROM CENTER TO OUTSIDE		NOISE LEVEL db(A)	AIR USAGE cfm
	mm	in		mm	in	lb	kg	mm	in		
US-3.5PB*	4	No. 8	2,000	200	7.9	1.7	0.8	17	0.7	75	7.0
US-3.5B	4	No. 8	2,000	214	8.5	1.4	0.6	17	0.7	75	7.0
US-5	5	No. 10	1,400	236	7.1	2.4	1.1	21	0.8	75	7.0

* Push-To-Start

Air Hose Size: 1/4" I.D. for all models

Air Inlet: N.P.T. 1/4"



US-350PW

IMPACT SERIES

Recommended Air Pressure: 85 psi

MODEL	CAPACITY (SCREW SIZE)		FREE SPEED rpm	OVERALL LENGTH		WEIGHT LESS BIT		FROM CENTER TO OUTSIDE		NOISE LEVEL db(A)	AIR USAGE cfm
	mm	in		mm	in	lb	kg	mm	in		
PISTOL											
US-350PW	4	No. 8	15,000	121	4.8	1.2	0.5	17	0.7	81	7.0
US-450PW	5	No. 10	14,000	151	5.9	1.7	0.8	17	0.7	79	7.0
US-652PW	6	1/4	9,000	155	6.1	1.9	0.9	23	0.9	79	12.4
STRAIGHT											
US-450WB	5	No. 10	11,000	161	6.3	1.2	0.6	18.5	0.7	80	7.0

Air Hose Size: 1/4" I.D.

Air Inlet: N.P.T. 1/4"

Recommended air pressure: 57 psi for US-350PW, US-450PW, and US-450WB / 72 psi for US-652PW.

(R) Denotes Directional Muffled Rear Exhaust option

NOTE: Additional models available. Please contact AIMCO, 1-800-852-1368

SIGNATURE SERIES PRECISION CLUTCH CORDLESS TOOLS



SIGNATURE SERIES PRECISION TOOLS

Simple to use, yet sophisticated in performance, the AIMCO Signature Series pistol tools provide the operator the performance required to meet the needs of today's cordless tool applications.

The ergonomic handle design provides the operator ideal balance and weight. These tools allow for fastening in hard-to-reach locations at torques up to 9 ft-lb (12 NM) in the pistol configuration and 52 ft-lb (70 NM) in the angle nutrunner configuration. The Signature Series Precision Clutch range features a wide range of torque outputs and the ability to program the tool speed for the demands of the application. Bright LED indicator lights provide clear feedback to the operator on OK/NOK tightening result, Tool Direction setting, and Battery Status. Signature Series Precision tools all operate with a single 18V Li-Ion Battery and common chargers to maximize flexibility while minimizing cost associated with differing battery chemistries.

SIGNATURE SERIES PRECISE QUICK RELEASE CLUTCH

The Signature Series tool features a quick releasing clutch that delivers accuracy across multiple joint types. Each clutch assembly is constructed of precisely machined parts to guarantee accuracy and durability over the life of the tool. In addition to tight tolerances, the driving anvil is well supported to ensure that torque is precisely sensed by the clutch and not influenced by side loads or runout of the tool's rotating components.

Whether the application is made up of soft materials, such as plastics or gaskets, or harder materials, such as direct metal to metal joints, the Signature Series Precision Clutch tool delivers the accuracy the job requires.

Typical Torque Graph of the Signature Series Precision Cordless Tools

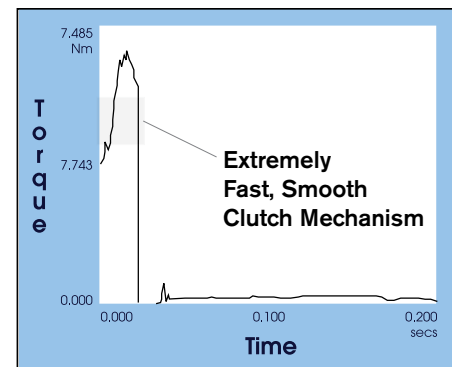

SIGNATURE SERIES PRECISION CLUTCH CORDLESS TOOLS



MODEL	TORQUE RANGE		FREE SPEED RPM RANGE (Programmable with Programmer Accessory)	BATTERY VOLTAGE	TOOL WEIGHT (W/O BATTERY)		ANVIL SIZE
	ft-lb	Nm			lb	kg	
Pistol Grip							
SPC-P2325Q	.6 - 2.2	.8 - 3	500 - 1550	18V	2.1	.95	1/4" hex
SPC-P2625Q	.7 - 4.4	1 - 6	300 - 1000	18V	2.1	.95	1/4" hex
SPC-P2925Q	1.1 - 6.6	1.5 - 9	300 - 800	18V	2.1	.95	1/4" hex
SPC-P21225Q	1.5 - 8.8	2 - 12	250 - 600	18V	2.1	.95	1/4" hex
Angle Nutrunner							
SPC-A21025Q	2.2 - 8.8	3 - 12	400 - 1000	18V	3.5	1.6	1/4" hex
SPC-A21025	2.2 - 8.8	3 - 12	400 - 1000	18V	3.5	1.6	1/4" Sq
SPC-A21038	2.2 - 8.8	3 - 12	400 - 1000	18V	3.5	1.6	3/8" Sq
SPC-A21625Q	3.7 - 13.3	5 - 18	300 - 600	18V	3.5	1.6	1/4" hex
SPC-A21625	3.7 - 13.3	5 - 18	300 - 600	18V	3.5	1.6	1/4" Sq
SPC-A21638	3.7 - 13.3	5 - 18	300 - 600	18V	3.5	1.6	3/8" Sq
SPC-A23038	5.9 - 22	8 - 30	250 - 480	18V	3.5	1.6	3/8" Sq
SPC-A23538	7.4 - 25.8	10 - 35	220 - 330	18V	3.5	1.6	3/8" Sq
SPC-A25038	7.4 - 37	10 - 50	200 Non-Programmable Fixed Speed*	18V	5.3	2.4	3/8" Sq
SPC-A27038	14.8 - 51.7	20 - 70	170 Non-Programmable Fixed Speed*	18V	6.3	2.9	3/8" Sq

- Pistol Grip Tools include: Torque Adjustment Tool and one (1) 18V Li-Ion Battery
- Angle Nutrunners include: Torque Adjustment Tool, Head Indexing Spanner Wrench, and one (1) 18V Li-Ion Battery
- * High torque tools feature fixed RPM.

Signature Series tools can be adapted to a wide range of application-specific configurations. Contact your AIMCO Representative for assistance, 1-800-852-1368.

SIGNATURE SERIES BATTERY, CHARGER, AND ACCESSORIES

BATTERIES AND CHARGERS

The AIMCO Signature Series battery and charging system could not be more simple. One universal battery and one universal charger interface with any of the Signature Series Precision Clutch tools. Pistol type, angle type, low amount of torque output, or the highest torque tool in the range, each tool utilizes the same 18V Lithium Ion battery for superior charge life and weight. The charger accepts input AC power of 100–240AC, making use simple anywhere in the world.

The Signature Series battery features a slim profile design and a slide mount connection to the tool, which ensures durability and makes changing out batteries simple.



SPC-B218LI



SPC-C218-19

BATTERY AND CHARGER SPECIFICATIONS

BATTERY MODEL NUMBER	VOLTAGE	TYPE	CAPACITY	WEIGHT
SPC-B218LI	18V	Li-Ion	2.0Ah	.8 Lb/.4 kg
SPC-B218LI-HC	18V	Li-Ion	4.0Ah	1.4 Lb/.64 kg
CHARGER MODEL NUMBER	OUTPUT	INPUT	DIMENSIONS	WEIGHT
SPC-C218-19	18V-19.2V, 3.0A	100-240VAC, 50-60Hz	6.25" deep X 5" wide X 3.5" tall (w/o Battery) 158.75 mm X 127 mm X 89 mm	1.2 Lb/.54 kg

TOOL SPEED PROGRAMMER

The Signature Series Precision Cordless tool line is capable of specifically programming the running RPM into the tool within its range of operation. Each tool in the range has an integrated Mini USB



SPC-2-PGM

connector that couples to the Signature Series Programmer module. Simply connect the tool to the Programmer Module and flash the tool to the desired RPM. Once flashed, the tool will hold the RPM setting until a change is desired and it is re-flashed. New tools, that have not been specifically set by the programmer module, will run at their maximum rated RPM as shown in the catalog and on the tool label.

QUICK CLIP

Carry your Signature Series Pistol tool on any work belt with the Quick Clip. The two piece Quick Clip comes with a belt clip and a stretch cord attachment for the tool. The patented ball feature allows for quick and easy release on the belt. The Quick Clip keeps the tool well balanced and frees the operator's hands for other tasks.



SPC-QC



HOLSTERS



Easily carry your Signature Series pistol and right angle tools. AIMCO offers right-hand and left-hand holsters.

SPC-P-HL

BODY JACKETS

MODEL	DESCRIPTION
 BJ10082	For Signature Series G2 Pistol Tools
 BJ10083	For Signature Series G2 Angle Nutrunners

TOOL BASKETS



21226

Tool Baskets are a great way to keep the Signature Series tool in place when not being used. AIMCO tool baskets can be affixed to a bench or rack and can be used for either a pistol or right angle tool.

ELECTRIC SCREWDRIVERS

ELECTRA SERIES

- Available in push-to-start and lever start styles.
- Ergonomic design – Lightweight, compact housings ensure operator comfort during operation.
- Accurate torque control – Precise controlled fastening with automatic shut-off clutches.
- External brush replacement – Virtually no down time for brush replacement.
- External torque adjustment – Torque level can be easily adjusted by simply turning the external adjustment ring.



AE-5681



- UL Listed and CE Certified – Drivers meet electrical safety standards in both the U.S. and Europe.
- Direct plug-in style – Offers easy and convenient start-up (certain models) simply plug it in.
- State-of-the-art motor design – Ensures comfortable grip temperature for operator and extended motor life.

ELECTRA SERIES

MODEL	TORQUE RANGE		FREE SPEED RPM	WEIGHT		LENGTH		HEX DRIVE		POWER SOURCE
	IN-LB	KGF-CM		LB	KG	IN	MM	IN	MM	
PUSH-TO-START DIRECT PLUG-IN SERIES										
AE-5681 ³	3.5 - 15.6	4 - 18.0	1,000	1.2	0.5	9.3	237	1/4	6.4	115V AC ¹
AE-8681 ⁴	15 - 45	23.0 - 51.8	600	1.6	0.7	10.6	269	1/4	6.4	115V AC ¹
LOW VOLTAGE LEVER START SERIES ²										POWER SUPPLY:
AE-2020	.35 - 1.3	.40 - 1.5	720	0.7	0.3	8.0	203	1/4	6.4	See page 29 for
AE-4020	.9 - 5	1.0 - 6.0	720	0.7	0.3	8.0	203	1/4	6.4	required power
AE-4520	1.3 - 8.7	1.5 - 10.0	720	0.7	0.3	8.0	203	1/4	6.4	supplies ²
AE-7010	6.1 - 17.4	7.0 - 20.0	750	1.4	0.6	9.3	236	1/4	6.4	
AE-8010	10.4 - 26.0	12.0 - 29.9	550	1.4	0.6	9.3	236	1/4	6.4	
LOW VOLTAGE PUSH-TO-START SERIES ²										POWER SUPPLY:
AE-7010PS	6.1 - 17.4	7.0 - 20.0	750	1.4	0.6	9.3	236	1/4	6.4	See page 29 for
AE-8010PS	10.4 - 26.0	12.0 - 29.9	550	1.4	0.6	9.3	236	1/4	6.4	power supplies ²

- ¹ 220V AC is available upon request. Contact AIMCO at 1-800-852-1368.
- ² Low voltage units require an external power supply.

- ³ AE-5681 includes a torque cover.
- ⁴ AE-8681 includes a pistol grip handle adapter

ELECTRA LOW ESD SERIES

- Grounded bit – Grounded chuck assembly routes any existing charge to ground.
- Carbonized housing – Handle material and buttons are constructed of carbonized plastic throughout, enabling any charge received by the handle to be routed to ground.
- Long-Lasting ESD resistant handle – Material will maintain its integrity for the life of the handle, unlike coatings or paints.



AE-5681ESD



ELECTRA LOW ESD SERIES

MODEL	TORQUE RANGE		FREE SPEED RPM	WEIGHT		LENGTH		HEX DRIVE		POWER SOURCE
	IN-LB	KGF-CM		LB	KG	IN	MM	IN	MM	
AE-2020ESD	.35 - 1.3	.40 - 1.5	720	0.7	0.3	8.0	203	1/4	6.4	See page 29
AE-4520ESD ²	1.3 - 8.7	1.5 - 10.0	720	0.9	0.4	8.0	204	1/4	6.4	35V DC
AE-5681ESD	3.5 - 15.6	4 - 18.0	1,000	1.2	0.5	9.3	237	1/4	6.4	115V AC ¹

- ¹ 220V AC is available upon request. Contact AIMCO at 1-800-852-1368.
- ² Low voltage units require an external power supply.

ELECTRIC SCREWDRIVERS

ELECTRA SLIP CLUTCH SERIES

- High-speed performance – For quick and consistent assembly and disassembly
- Maximum ergonomics and convenience – Offers a combination of a slip clutch with a high speed motor to provide low torque reaction; one of the best power-to-weight ratios in the industry.
- Added maintenance feature – LED light indicates when to change brushes. Brush cap contains a switch that shuts off the power during brush replacement.
- Direct 110V plug-in – Eliminates the need for an external power supply.



AE-2015



- 1/4" hex quick change chuck – For easy bit changes
- External torque collar – For easy torque adjustment.

ELECTRA SLIP CLUTCH SERIES

MODEL	RECOMMENDED TORQUE RANGE		FREE SPEED RPM	WEIGHT		LENGTH		HEX DRIVE		POWER SOURCE
	IN-LB	KG-F-CM		LB	KG	IN	MM	IN	MM	
AE-2015	4.3 - 21.7	5.0 - 25.0	1000	1.2	.55	9.2	234	1/4	6.4	110 V / 120V AC ¹

¹ 220V AC is available upon request. Contact AIMCO at 1-800-852-1368.

PRECISION SERIES

For low torque applications

- Featuring ergonomic design in shape and materials.
- Comes with options such as long-life brushless motors and adjustable speed power supplies.

STANDARD MODELS

- Optional speed control power supply – Enables infinite control from 20% to 100% of maximum tool speed and adjustable soft start to minimize cross threading.
- Ergonomic housing – Oval shape conforms to hand.
- Duralite – Casing material provides a secure grip.
- Integrated Lever – Feather touch integrated lever reduces travel and stress. Requires only 2 mm of travel to activate.
- External torque control – Twist and go.

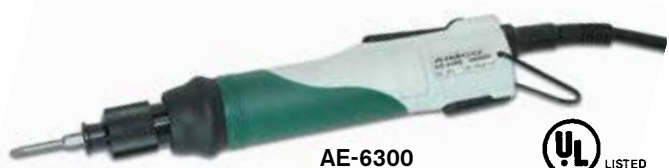

AE-6300



EXTENDED LIFE MODELS

- Sealed Swiss motor – For higher duty cycles, longer life, and less maintenance. Sealed casing means no brush changes are necessary.
- Extended warranty on tool motor – Three year standard motor warranty.
- Compact power supply – Makes setup a breeze.

PRECISION SERIES

MODEL	TORQUE RANGE		FREE SPEED RPM	WEIGHT		LENGTH		HEX DRIVE IN	
	IN-LB	KG-F-CM		LB	KG	IN	MM		
STANDARD									
AE-6300	.85 - 5.0	1.0 - 5.8	725	0.9	0.4	8.5	216	1/4	
AE-6450	1.3 - 8.7	1.5 - 10.0	770	0.9	0.4	8.5	216	1/4	
HIGH SPEED									
AE-6300S	1.2 - 5.5	1.4 - 6.3	920	0.9	0.4	8.5	216	1/4	
AE-6450S	1.3 - 8.7	1.5 - 10.0	920	0.9	0.4	8.5	216	1/4	
EXTENDED LIFE									
AE-6300M	1.0 - 5.5	1.1 - 6.3	550	0.9	0.4	8.5	216	1/4	

ELECTRIC SCREWDRIVERS



APS-35W



APM-30



AE-224PS
AE-278PS

ELECTRA SERIES ACCESSORIES - POWER SUPPLIES

MODEL	COMPATIBLE SCREWDRIVERS	TOOL RPM	VOLTAGE CONVERSION	DIMENSIONS (LB)	WEIGHT (KG)	
AE-224PS	AE-2020 AE-2020ESD AE-4020 AE-4520 AE-4520ESD	AE-6300 AE-6300S AE-6450 AE-6450S	720	110V AC / 35V DC	2.6 x 1.6 x 5.0 66 x 41 x 127 mm	1.0 .45
APS-35W	AE-2020 AE-2020ESD AE-4020 AE-4520 AE-4520ESD	AE-6300 AE-6300S AE-6450 AE-6450S	VARIABLE SPEED / SOFT START	110V AC / 35V DC	2.6 x 1.6 x 5.0 66 x 41 x 127 mm	1.0 .05
AE-278PS	AE-7010 AE-7010PS	AE-8010 AE-8010PS	STANDARD	110V AC - 220V AC / 30V DC	1.6 x 5.0 x 2.6 41 x 127 x 66 mm	1.0 .45
APM-30	AE-6300M		550	110V AC - 220V AC / 30V DC	2.1 x 3.4 x 1.9 53 x 87 x 48mm	0.4 .02



ANGLE HEAD ATTACHMENTS

Available for lever start series.

Not available for Low ESD Series.



PISTOL GRIP HANDLE

Converts to a pistol style driver for horizontal fastening. Available for Trigger Start only (included with AE-8681).



TORQUE COVER

Prevents accidental torque adjustment by the operator (included with AE-5681).



FASTENER COUNTER

Verifies and error-proofs assembly process.

OPTIONAL ACCESSORIES

ITEM	MODEL	COMPATIBLE SCREWDRIVERS
Angle Head Attachments	AE-2045A	For AE-2020, AE-4020, AE-4520
	AE-7080A	For AE-7010, AE-8010
Pistol Grip Handle	AE-PG7080	For AE-7010, AE-1070PS, AE-8010, AE-8010PS
Torque Cover	AE-TC2040	For AE-2020, AE-4020, AE-4520
	AE-TC7080	For AE-7010, AE-7010PS, AE-8010, AE-8010PS
	4H2055	For AE-8681
Fastener Counter	TM-45	For AE-2020, AE-4020, AE-4520 Standard and ESD types
	TM-65	For AE-7010, AE-8010 and AE-8010PS

IMPACT TOOLS

UW-SERIES IMPACT TOOLS

UW-Series impact tools offer fast, economical operation in high-volume heavy assembly applications.

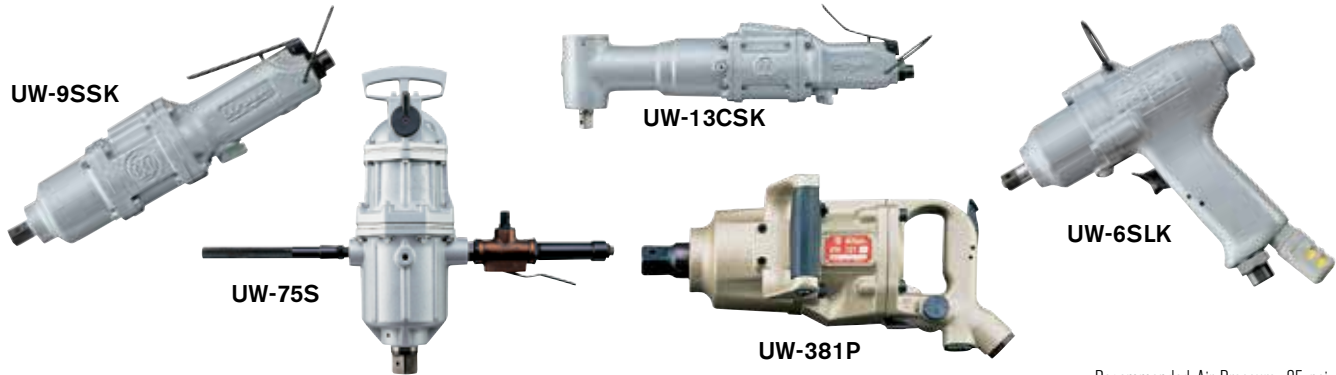

Recommended Air Pressure: 85 psi

MODEL	CAPACITY		TORQUE RANGE (APPROX)		SPEED RPM	OVERALL LENGTH		WEIGHT KG	WEIGHT LB	FROM CENTER TO OUTSIDE		SQ. DR. OR HEX SIZE IN	NOISE LEVEL DB(A)	AVERAGE AIR CONSUMPTION
	MM	IN	NM	FT-LB		MM	IN			MM	IN			
PISTOL														
UW-6SLRDK	6	1/4	6.9 - 18	5 - 13	8,500	175	6.9	1.0	2.1	31.0	1.2	1/4 Hex	91	12.4
UW-6SLK	6	1/4	7.8 - 19	6 - 14	8,500	175	6.9	1.0	2.1	31.0	1.2	1/4 Sq.	92	12.4
UW-6SLRK	6	1/4	6.9 - 18	5 - 13	8,500	175	6.9	1.1	2.1	31.0	1.2	3/8 Sq.	92	10.5
UW-61ER(D)K	8	5/16	14 - 40	10 - 30	7,300	150	5.9	1.5	3.3	29.5	1.2	3/8 Sq.	91	12.4
UW-8SHK	8	5/16	29 - 69	21 - 51	7,500	172	6.8	1.6	3.4	31.0	1.2	1/2 Sq.	93	14.0
UW-8SHRK	8	5/16	18 - 40	13 - 30	7,300	172	6.8	1.6	3.4	31.0	1.2	1/2 Sq.	93	14.0
UW-9SRK	10	3/8	35 - 87	26 - 64	7,000	178	7.0	1.8	3.9	34.0	1.3	1/2 Sq.	93	16.0
UW-9SK	10	3/8	35 - 87	26 - 64	7,000	178	7.0	1.8	4.0	34.0	1.3	1/2 Sq.	95	17.6
UW-10SHK	12	1/2	49 - 180	36 - 133	6,500	183	7.2	2.1	4.7	35.0	1.4	1/2 Sq.	95	16.0
UW-10SHRK	12	1/2	47 - 170	35 - 125	6,000	183	7.2	2.1	4.7	30.5	1.4	1/2 Sq.	95	16.0
UW-13SK	13	1/2	88 - 250	65 - 184	6,500	215	8.5	2.6	5.7	37.5	1.5	1/2 Sq.	95	19.4
UW-13SRK	13	1/2	88 - 250	65 - 184	6,000	215	8.5	2.6	5.7	37.5	1.5	1/2 Sq.	95	16.0
INLINE														
UW-6SSDK	6	1/4	7.8 - 22	6 - 16	7,500	185	7.3	1.0	2.1	28.0	1.1	1/4 Hex	91	10.5
UW-6SSHDK	8	5/16	15 - 30	11 - 22	7,500	205	8.1	1.2	2.7	22.0	0.8	1/4 Hex	91	12.4
UW-6SSLRDK	6	1/4	6.9 - 18	5 - 13	8,500	239	9.4	0.9	1.9	31.0	1.3	1/4 Hex	91	10.5
UW-6SSHK	8	5/16	22 - 50	16 - 37	7,500	205	8.1	1.3	2.7	27.5	1.1	1/4 Sq.	92	12.4
UW-6SSHRDK	8	5/16	15 - 30	11 - 22	7,300	249	9.8	1.3	2.8	27.5	1.1	1/4 Hex	91	12.4
UW-6SSHRK	8	5/16	22 - 50	16 - 37	7,300	249	9.8	1.3	2.8	27.5	1.1	3/8 Sq.	91	12.4
UW-9SSK	10	3/8	35 - 87	26 - 64	7,000	290	11.4	2.1	4.6	34.0	1.3	1/2 Sq.	95	16.0
ANGLE														
UW-6CSK	6	1/4	7.8 - 22	6 - 16	7,500	218	8.6	1.4	3.1	28.0	1.1	3/8 Sq.	94	10.5
UW-6CSHK	8	5/16	19 - 41	14 - 30	7,500	238	9.4	1.7	3.8	27.5	1.1	3/8 Sq.	94	12.4
UW-6CSHRK	8	5/16	19 - 41	14 - 30	7,300	282	11.1	1.7	3.8	27.5	1.1	3/8 Sq.	94	10.5
UW-9CSK	10	3/8	27 - 71	20 - 52	7,000	337	13.3	2.8	6.1	34.0	1.3	1/2 Sq.	95	12.4
UW-13CSK	13	1/2	75 - 200	55 - 148	6,500	374	14.7	5.2	11.4	39.0	1.5	1/2 Sq.	97	26.5
SWING HAMMER														
UW-140P(WR)	12	1/2	70 - 210	52 - 155	6,500	200	7.9	2.7	5.9	33.0	1.3	1/2 Sq.	93	25.0
UW-381	38	1-1/2	760 - 2,000	561 - 1,475	4,700	395	115.6	9.5	20.9	58.5	2.3	1 Sq.	100	31.5
UW-381P	38	1-1/2	760 - 2,000	561 - 1,475	4,700	276	10.9	10.0	20.9	58.5	2.3	1 Sq.	99	31.5
JUMBO														
UW-75S	76	3	7,800 - 17,000	5,753 - 12,539	1,400	670	26.4	56.0	123.0	96.0	3.8	1-1/2 Sq.	112	114.0

Air Hose Size: 3/8" I.D. (UW-6 - 140P)
1/2 I.D. (UW-381, UW-381P)
3/4 I.D. (UW-75S)

Air Inlet: N.P.T. 1/4" (UW-6 - 140P)
N.P.T. 1/2" (UW-381, UW-381P)
N.P.T. 1" (UW-75S)

NOTE: Additional models available. Please contact AIMCO, 1-800-852-1368.

IMPACT TOOLS MODEL NUMBER KEY

C: Angle Head **D:** Quick Change Driver **E:** Built-in Air Regulator **H:** Heavy Duty **L:** Long Anvil **R:** Rear Air Exhaust **SS:** Inline

GRINDERS AND SANDERS

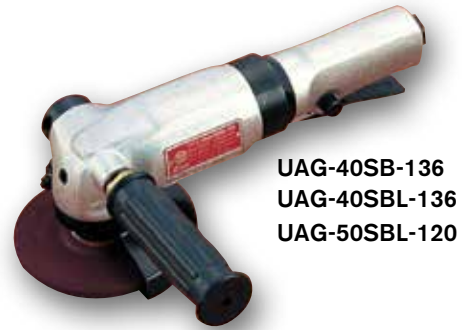
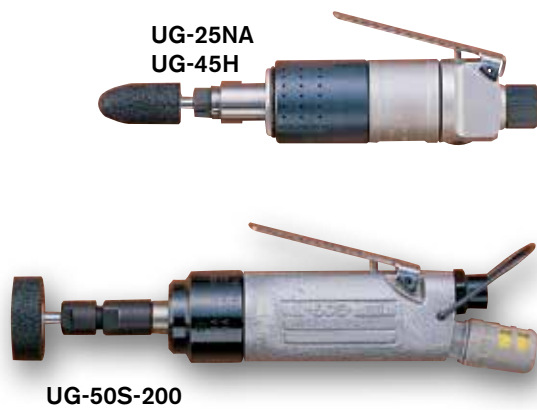

GRINDERS

Recommended Air Pressure: 85 psi

MODEL	CAPACITY (WHEEL SIZE)	SPEED RPM	RATED	OVERALL LENGTH		OVERALL HEIGHT		WEIGHT		NOISE LEVEL DB(A)	AVERAGE AIR CONSUMPTION CFM
	IN		HORSEPOWER HP	MM	IN	MM	IN	KG	LB		
UAG-40SBL-136	4	13,600	1.0	246	9.7	76	3.0	1.3	2.9	84	34.0
UAG-50SBL-109	5	10,900	1.0	246	9.7	76	3.0	1.4	3.1	82	34.0
UAG-50SBL-120	5	12,000	1.0	246	9.7	76	3.0	1.4	3.1	82	34.0
UAG-70SBL-76	7	7,600	2.0	300	11.8	98	3.9	2.9	6.4	83	57.0
UAG-90SBL-59	9	5,900	2.5	308	12.1	98	3.9	3.3	7.3	88	67.0

Air Hose Size: 3/8" I.D.

Air Inlet: N.P.T. 1/4" - N.P.T. 3/8" (UAG-90SBL-59)

NOTE: Additional models available. Please contact AIMCO, 1-800-852-1368.

GRINDERS / SANDERS

Recommended Air Pressure: 85 psi

MODEL	CAPACITY (WHEEL SIZE)	COLLET CHUCK SIZE	SPEED RPM	RATED	OVERALL LENGTH		WEIGHT		NOISE LEVEL DB(A)	AVERAGE AIR CONSUMPTION CFM
	IN	IN		HORSEPOWER HP	MM	IN	KG	LB		
UG-25NA	-	1/4	23,500	0.3	153	6.0	0.5	1.2	82	10.7
UG-38N	-	1/4	25,000	0.4	164	6.5	0.6	1.3	85	10.7
UG-38NA	-	1/4	22,000	0.4	165	6.5	0.7	1.4	75	14.0
UG-38NL	-	1/4	21,000	0.4	317	12.5	0.9	2.0	85	10.7
UG-38NS	-	1/4	25,000	0.4	174	6.8	0.6	1.3	85	10.7
UG-50S-200	-	1/4	23,000	0.3	198	7.8	0.6	1.3	73	14.0
UG-45H	-	1/4	18,000	0.5	196	7.7	0.8	1.8	76	22.0
UG-20A-200	-	1/4	20,000	0.2	131	5.2	0.5	1.1	75	10.7
UG-20A-120	-	1/4	12,000	0.2	131	5.2	0.5	1.1	76	10.7
UG-50S-200A	-	1/4	20,000	0.3	195	7.7	0.9	2.0	75	14.0
UG-65EB	2.5	-	14,600	0.6	242	9.8	1.3	2.8	95	22.0
UG-65EL	2.5	-	14,600	0.6	272	10.7	1.4	3.1	85	22.0
UG-65ER	2.5	-	14,600	0.6	271	10.7	1.5	3.3	85	22.0
UG-65EBL	2.5	-	14,600	0.6	272	10.7	1.4	3.1	95	22.0
UG-65OEL	2.5	-	14,600	0.6	420	16.5	1.6	3.4	85	22.0
UG-125OL-72	5	-	7,200	1.0	436	17.2	2.8	6.2	88	32.7
UP-25DB	5	-	10,000	0.3	212	8.3	1.7	3.7	73	7.0
UP-25NB	5	-	9,000	0.4	250	9.4	1.8	3.9	97	21.0

Air Hose Size: 3/8" I.D. - 1/2" I.D. (UG-125OL-72)

Air Inlet: N.P.T. 1/4" N.P.T. 3/8" (UG-125OL-72)

NOTE: Additional models available. Please contact AIMCO, 1-800-852-1368.

DRILLS & PERCUSSION TOOLS



UD-60S-29

DRILLS

Recommended Air Pressure: 85 psi

MODEL	CAPACITY		SPEED RPM	OVERALL LENGTH		WEIGHT WITH CHUCK		FROM CENTER TO OUTSIDE		NOMINAL CHUCK SIZE IN	TYPE OF SPINDLE IN-THR'D	NOISE LEVEL DB(A)	AVERAGE AIR CONSUMPTION CFM
	MM	IN		MM	IN	KG	LB	MM	IN				
UD-50-200	3	1/8	23,000	135	5.3	0.7	1.5	21.0	0.8	5/16	3/8-24UNF	73	14
UD-50-45	6	1/4	5,000	145	5.7	0.9	1.9	21.0	0.8	5/16	3/8-24UNF	72	14
UD-50-22	8	5/16	2,200	140	5.5	0.9	2.0	21.0	0.8	5/16	3/8-24UNF	72	14
UD-60-29	8	5/16	2,900	167	6.6	1.1	2.4	22.5	0.9	5/16	3/8-24UNF	77	18
UD-60-20	8	5/16	2,000	180	7.1	1.2	2.6	22.5	0.9	5/16	3/8-24UNF	77	18
UD-60-15	8	5/16	1,600	180	7.1	1.2	2.6	22.5	0.9	5/16	3/8-24UNF	76	18
UD-60-07	13	1/2	700	219	8.6	1.4	3.1	22.5	0.9	1/2	1/2-20UNF	75	18
UD-60-04	13	1/2	500	220	8.6	1.4	3.1	22.5	0.9	1/2	1/2-20UNF	75	18
UD-80-12	13	1/2	1,200	216	8.5	1.8	4.0	26.0	1.0	1/2	1/2-20UNF	79	23
UD-80-07	13	1/2	700	239	9.4	2.3	5.1	26.0	1.0	1/2	1/2-20UNF	79	23
UD-80-04	16	5/8	400	247	9.7	2.9	6.4	26.0	1.0	5/8	5/8-16UNF	79	23
UD-50S-45	6	1/4	5,000	210	8.3	0.9	1.9	21.0	0.8	5/16	3/8-24UNF	77	14
UD-50S-22	8	5/16	2,200	205	8.1	0.8	1.8	21.0	0.8	5/16	3/8-24UNF	77	14
UD-60S-29	8	5/16	2,900	227	8.9	1.1	2.3	22.5	0.9	5/16	3/8-24UNF	77	18
UD-60S-15	8	5/16	1,600	238	9.4	1.2	2.5	22.5	0.9	5/16	3/8-24UNF	77	18
UD-60S-29C	8	5/16	2,900	276	10.9	1.5	3.3	22.5	0.9	5/16	3/8-24UNF	79	18
UD-60S-15C	8	5/16	1,600	283	11.1	1.6	3.5	22.5	0.9	5/16	3/8-24UNF	79	18

Air Hose Size: 3/8" I.D. Air Inlet: N.P.T. 1/4"

NOTE: Other models are available. Please contact AIMCO, 1-800-852-1368.

RIVETING HAMMERS

Recommended Air Pressure: 85 psi

MODEL	CAPACITY		BLOW PER MIN. BPM	OVERALL LENGTH		WEIGHT		PISTON DIAMETER		PISTON STROKE		NOISE LEVEL DB(A)	AVERAGE AIR CONSUMPTION CFM
	DURALUMIN IN	STEEL IN		MM	IN	KG	LB	MM	IN	MM	IN		
SBH-0	3/32	-	6,500	123	4.8	0.3	0.7	10.0	0.4	23	0.9	90	3.5
SBH-1A(R,H)*	7/64	-	4,000	209	8.2	0.9	1.9	11.1	0.4	56	2.2	92	5.0
BRH-1U(R,H)*	1/8	3/32	2,800	122	4.9	1.1	2.4	14.3	0.6	38	1.5	95	12.0
BRH-1US(R,H)*	1/8	3/32	2,800	180	7.1	1.0	2.2	14.3	0.6	38	1.5	95	12.0
BRH-1UG(R,H)*	1/8	3/32	2,800	187	7.4	1.8	3.9	14.3	0.6	38	1.5	95	12.0
BRH-5U(R,H)*	1/4	3/16	1,800	189	7.4	1.4	3.1	12.7	0.5	100	4.0	95	13.0
BRH-5US(R,H)*	1/4	3/16	1,800	246	9.7	1.5	3.2	12.7	0.5	100	4.0	95	13.0
BRH-5UG(R,H)*	1/4	3/16	1,800	258	10.2	2.1	4.7	12.7	0.5	100	4.0	95	13.0
BRH-1UV(R,H)*	1/8	3/32	2,800	143	5.6	1.4	3.0	14.3	0.6	38	1.5	91	12.0
BRH-5UV(R,H)*	1/4	3/16	1,800	210	8.3	1.7	3.7	12.7	0.5	100	4.0	91	13.0
BRH-1USV(R,H)*	1/8	3/32	2,800	271	10.7	1.6	3.5	14.3	0.6	38	1.5	91	12.0
BRH-5USV(R,H)*	1/4	3/16	1,800	338	13.3	1.9	4.1	12.7	0.5	100	4.0	91	12.0
BRH-7(R,H)*	-	-	3,400	168	6.6	1.6	3.6	19.1	0.8	50	2.0	100	17.0

Air Hose Size: 3/8" I.D.

Air Inlet: N.P.T. 1/4"

* R - Round Bushing

H - Hex Bushing

ONE SHOT HAMMERS

Recommended Air Pressure: 85 psi

MODEL	BLOW POWER LB	RIVET SET DIA X LENGTH IN	SHANK DIAMETER		STROKE		LENGTH		WEIGHT	
			MM	IN	MM	IN	MM	IN	LB	KG
CB-13P	1.7	4.04 x 9.86	-	-	3.0	0.12	185	7.3	0.7	0.3
RH-25	20.4	-	10.2	0.401	29.8	1.2	213	8.4	2.0	0.9
RH-80	27.6	-	10.2	0.401	29.8	1.2	254	10.0	2.9	0.3
RH-90	103	-	10.2	0.401	29.8	1.2	328	12.9	3.5	1.6
RH-100Z	78.1	-	10.2	0.401	29.8	1.2	328	12.9	3.9	1.8
RH-200	139	-	10.2	0.401	39.8	1.2	341	13.4	4.6	2.1

Air Hose Size: 3/8" I.D.

Air Inlet: N.P.T. 1/4"

NOTE: Additional models available. Please contact AIMCO, 1-800-852-1368.



Visit our *NEW* website
WWW.AIMCO-GLOBAL.COM

AIMCO CORPORATE HEADQUARTERS

10000 SE Pine Street
Portland, Oregon 97216
Phone: (503) 254-6600
Toll Free: 1-800-852-1368

AIMCO CORPORATION DE MEXICO SA DE CV

Ave. Cristobal Colon 14529
Chihuahua, Chihuahua. 31125
Mexico
Phone: (01-614) 380-1010
Fax: (01-614) 380-1019

AIMCO EUROPE

C/ Río Gallo, 431 urb. Montelar
19174 Galápagos / Guadalajara
Spain
Phone: +34 673 34 99 25

AIMCO CHINA

Room 607, No. 3998 Hongxin Rd
Minhang District, Shanghai
China
Phone: 0086-21-34319246
Fax: 0086-21-34319245

AIMCO SOUTH AMERICA

Carrera 29A, #7B-91. Origami Building. Int604
Medellin; Colombia 050021

POWER T