

UEP-60MC SERIES ELECTRIC OIL-PULSE TOOL

EXPLODED VIEW

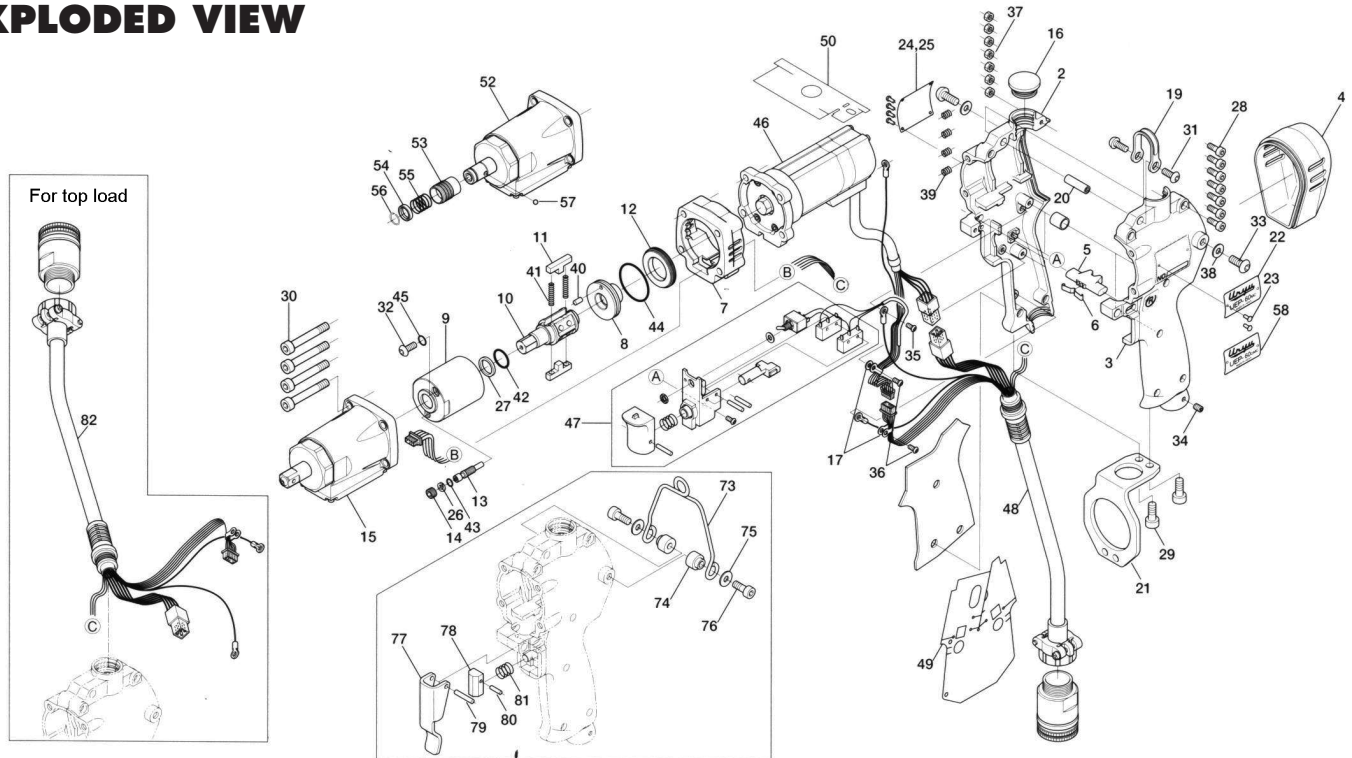

PARTS LIST — FOR REFERENCE ONLY

Index Number	Part Number	Description	Qty.	Index Number	Part Number	Description	Qty.	Index Number	Part Number	Description	Qty.
1	137-004-7	Handle Assembly	1	35	957-106-0	Cross Pan Head Screw (M4 x 6)	1	ACCESSORIES			
2	136-025-7	Handle Set	1 ●	36	957-215-0	Cross Pan Head Screw (M3 x 5)	2	63	910-532-0	Coil Cable Assembly	1
3	136-083-7	Handle Supporter	1 ●	37	960-020-0	Hexagon Nut (1-M3)	7 ●	64	910-546-0	Joint Cable Assembly (3 M)	1
4	136-004-7	Head Cover	1	38	961-012-0	Flat Washer (5 mm)	2	65	910-547-0	Joint Cable Assembly (5 M)	1
5	136-212-8	Reverse Lever	1	39	965-011-0	Heli-Sert (M5 x 1.5D)	4	66	910-548-0	Joint Cable Assembly (10 M)	1
6	136-217-7	Plate Spring	1	40	970-145-0	Pin (H)(2.5 x 3.5)	1	67	910-623-0	Sensor Cable Assembly (CE)	1
7	137-027-5	Separator	1	41	976-622-0	Spring (3.5 x 24) (0.4)	2	EXTENSION BAR			
8	137-901-5	Liner Rear Plate	1	42	990-152-0	O-Ring (P12) (NTN)	1	68	904-090-0	Extension Bar (3/8 x 45) (MC)	1
9	136-902-7	Liner	1	43	990-320-0	O-Ring (ARP-568-003)	1	69	953-104-0	Allen Head Flat Point Screw (M4 x 4)	1
10	137-319-5	Anvil	1	44	990-331-0	O-Ring (JW1530-21)	1	70	971-214-0	Pin (3 x 14)	1
11	136-440-8	Driving Blade	2	45	990-971-0	O-Ring (SNS-3)(NOK)	1	71	990-011-0	O-Ring (P12)	1
12	136-906-7	Liner Casing Setter	1	46	910-506-0	Electric Motor	1	72	910-632-0	Connector Cover	1
13	136-907-7	Relief Valve Spindle	1	47	910-602-0	Starting Switch Assembly	1	72-1	891-300-1	Socket Pin Assembly	1
14	136-969-7	Relief Valve Plate	1	48	910-526-0	Handle Cable Assembly (CE1.8)	1	OPTION: 851-100-1 SUSPENSION RING ASSEMBLY			
15	851-679-1	Sensor Casing Assembly (S4-9.5)	1	49	910-660-0	Insulation Sheet (Grip)	1	73	850-950-1	Suspension Ring	1
16	136-064-7	Plug	1	50	910-663-0	Insulation Sheet (Motor 60)	1	74	193-791-6	Suspension Receiver	2
17	136-670-7	Band	1	51	909-697-0	Shrink Tube (9 x 10)	4	75	193-792-6	Suspension Plate	2
19	136-790-7	Suspension Bail	1	52	851-678-1	Sensor Cable Assembly (S2-6.35)	1	76	945-112-0	Allen Head Bolt (M5 x 12)	2
20	136-791-7	Suspension Bail Base	1	53	011-351-1	Bit Sleeve (1/8)	1	OPTION: 851-104-1 LEVER ASSEMBLY			
21	136-794-7	Suspension Plate	1	54	011-352-1	Bit Spacer	1	77	163-107-6	Valve Lever	1
22	137-924-5	Name Plate	1	55	976-327-0	Spring (13.5 x 11) (0.9)	1	78	850-952-1	Valve Rod Cap	1
23	930-205-0	Driver Rivet (No.0 x 2.6)	6	56	978-117-0	Snap Ring (11.7 x 1)	1	79	970-222-0	Pin (H) (3 x 22)	1
24	136-993-7	Name Plate (Spec.) (230V)	1	57	981-002-0	Ball (1/8)	1	80	970-102-0	Pin (H) (2 x 16)	1
25	137-993-7	Name Plate (Spec.) (115V)	1	58	137-924-6	Name Plate	1	81	976-296-0	Spring (10.2 x 15) (0.6)	1
26	944-002-0	Supporting Ring (2.6 x 4.5 x 1)	1	PARTS FOR 230V				OPTION: FOR TOP LOAD			
27	944-214-0	Supporting Ring (12 x 15.9 x 1.5)	1	59	910-841-0	Driver Box UEPD-61E-CE (230V)	1	82	910-528-0	Handle Cable Assembly (CE)	1
28	945-016-0	Allen Head Bolt (M3 x 15)	7 ●	60	910-218-0	Power Cable (230V)	1				
29	945-112-0	Allen Head Bolt (M5 x 12)	2	PARTS FOR 115V							
30	945-145-0	Allen Head Bolt (M5 x 45)	4	61	910-845-0	Driver Box UEPD-61E-CE (230V)	1				
31	945-941-0	Hexagon Round Head Bolt (M4 x 5)	2	62	910-217-0	Power Cable (115V)	1				
32	945-942-0	Hexagon Round Head Bolt (M4 x 6)	1								
33	945-949-0	Hexagon Round Head Bolt (M5 x 6)	2								
34	954-105-0	Allen Head Cone Point Screw (M4 x 5)	1								

FOOTNOTES

● = Handle Assembly Components



10000 SE PINE
PORTLAND, OR 97216
503-254-6600
FAX 503-255-2615

When ordering spare parts, please specify tool type, part number, and description.

REVISED 05/16