

# UDP-TA55 SHUT-OFF ELECTRIC PULSE WRENCH

## EXPLODED VIEW

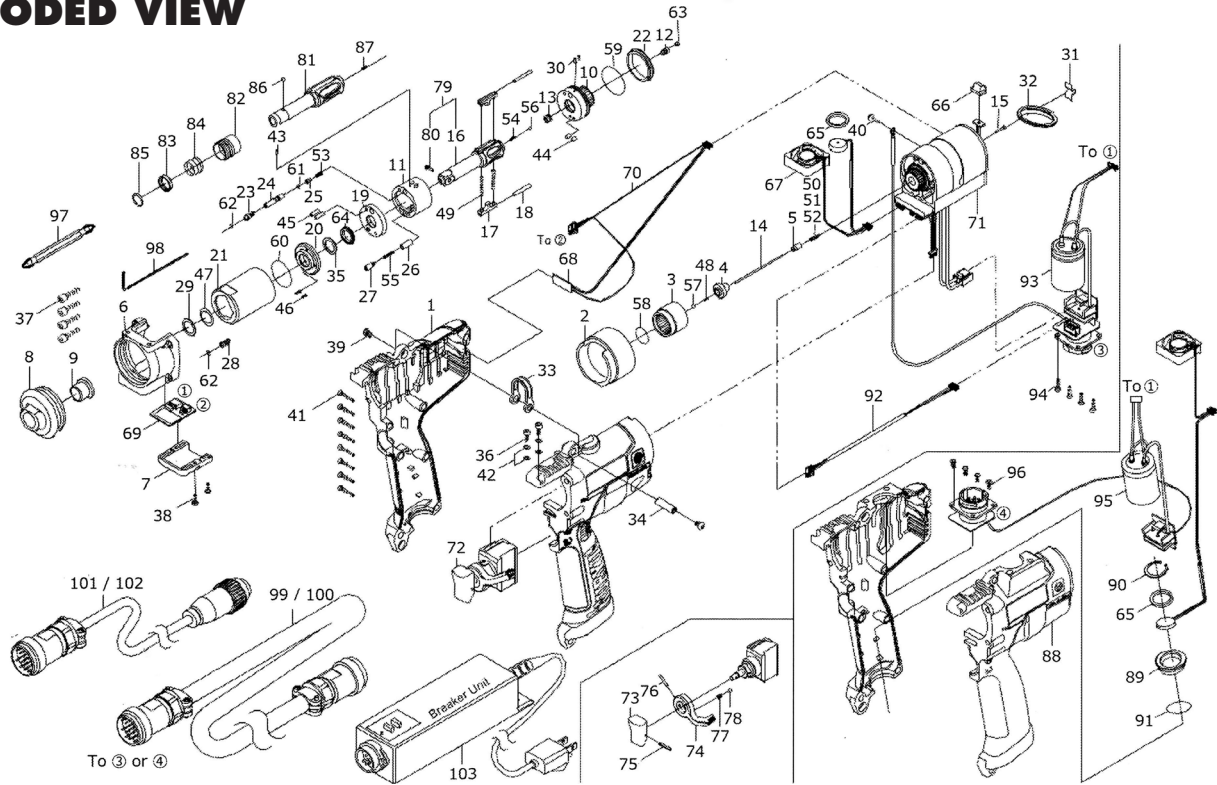

### PARTS LIST — FOR REFERENCE ONLY

Index Number	Part Number	Description	Qty.	Index Number	Part Number	Description	Qty.	Index Number	Part Number	Description	Qty.
1	073-025-6	Handle	1	37	945-018-0	Allen Head Bolt (M4 x 18)	4	73	147-107-2	Valve Lever	1
2	073-255-4	Regulator Barrel	1	38	945-023-0	Allen Head Bolt (2.5 x 8)	2	74	098-212-5	Reverse Lever	1
3	073-465-4	Internal Gear	1	39	945-941-0	Hexagon Round Head Bolt (M4 x 5)2	1	75	973-014-0	Roll Pin (2 x 14)	1
4	078-567-1	Bushing	1	40	948-001-0	Round Head Screw (M2.6 x 8)	1	76	973-018-0	Roll Pin (2 x 18)	1
5	078-318-1	Pilot Pin	1	41	963-253-0	Tapping Screw 3 x 16	8	77	976-006-0	Spring 3 x 5 (0.4)	1
6	078-035-1	Handle Connector	1	42	961-008-0	Flat Washer (3 mm)	4	78	981-002-0	Ball (1/8)	1
7	078-065-1	Casing Front Cover	1	43	970-013-0	Pin (H) (1.5 x 4)	1	79	891-552-1	Anvil CP (P)	1
8	078-439-3	Front Casing	1	44	970-130-0	Pin (H) (2.45 x 4.5)	2	80	891-300-1	Socket Pin Assembly	1
9	190-328-6	Anvil Bushing	1	45	970-131-0	Pin (H) (2.45 x 9.5)	2	81	145-350-7	Driver Anvil	1
10	078-901-3	Rear Liner Plate	1	46	973-040-0	Roll Pin (1.5 x 5)	2	82	011-351-1	Bit Sleeve	1
11	10E-902-1	Liner	1	47	975-754-0	Adjusting Spacer 17 x 12.5 x t)	1	83	011-352-1	Bit Spacer	1
12	145-546-6	Piston	1	48	976-518-0	Spring (1.9 x 5) (0.3)	1	84	976-327-0	Spring (13.5 x 11)	1
13	145-929-6	Check Valve Cover	1	49	976-805-0	Spring (3.5 x 25.2) (0.4) WPC	2	85	978-117-0	Snap Ring (11.7 x 1.0)	1
14	078-650-1	Rod	1	50	976-964-0	Spring 3.3 x 16.2 (0.5) n=13.5	1	86	981-002-0	Ball (1/8)	1
15	910-931-0	Rod Guide	1	51	976-771-0	Spring 3.3 x 16.5 (0.5) n=13.5	1	87	976-818-0	Spring 2.9 x 7.4 (0.4) n= 7.25	1
16	145-319-6	Anvil	1	52	976-968-0	Spring 3.3 x 18.2 (0.45)	1	88	073-025-7	Handle (TL)	1
17	145-440-6	Driving Blade	2	53	976-992-0	Spring 2.7 x 7.3 (0.4)	1	89	073-012-4	Handle Cover	1
18	145-974-6	Roller Pin (2.5 x 26)	2	54	976-653-0	Spring 2.4 x 5 (0.26)	1	90	979-320-0	Inner Snap Ring (IRTW-20)	1
19	18C-973-8	Liner Casing Spacer	1	55	976-999-0	Spring 3 x 12 (0.4) n=15.5	1	91	990-919-0	O-Ring (SNS-22)	1
20	145-904-6	Front Liner Plate	1	56	981-001-0	Ball (3/32)	1	92	910-966-0	TM Cable	1
21	145-905-6	Liner Casing	1	57	981-750-0	Ceramic Ball (1/8)	1	93	910-991-0	Power Source Board CP	1
22	145-906-6	Liner Casing Cover	1	58	990-016-0	O-Ring (P16)	1	94	963-252-0	Tapping Screw (3 x 10)	4
23	145-907-6	Relief Valve Spring	1	59	990-329-0	O-Ring (JW1530-19)	1	95	910-992-0	Power Source Board CP (TL)	1
24	094-970-4	Relief Valve	1	60	990-605-0	O-Ring (25 x 1.45)	1	96	957-009-0	Cross Pan Head Screw (M4 x 14)	4
25	144-270-0	Pressure Regulator Valve	1	61	990-621-0	O-Ring (3.8 x 1.8 x 1.0)	1	<b>STANDARD ACCESSORIES</b>			
26	080-274-6	Spring Holder	1	62	990-970-0	O-Ring (SNS-2) (NOK)	2	97	916-810-0	(+) Double Bit (No. 2 x 75) for D	1
27	18E-276-3	Pressure Adjusting Valve	1	63	991-025-0	X-Ring (4.7 x 2.2 x 1.25)	1	98	939-091-0	Allen Wrench 1.5 (80 x 20)	1
28	194-742-0	Oil Plug	1	64	991-030-0	X-Ring (X12)	1	<b>OPTIONAL ACCESSORIES</b>			
29	178-327-0	Anvil Front Spacer	1	65	993-102-0	Rubber Sponge Ring 16 x 20.5 x 2)	1	99	910-618-0	Joint Cable Assembly 5M	1
30	150-064-5	Plug	2	66	910-580-0	Front Cover	1	100	910-619-0	Joint Cable Assembly 10M	1
31	073-792-4	Suspension Bushing	1	67	910-487-0	Fan and Buzzer Assembly	1	101	910-627-0	Connecting Cable Assembly 5M	1
32	004-790-2	Suspension Ring	1	68	910-987-0	Switch Board Assembly	1	102	910-628-0	Connecting Cable Assembly 10M	1
33	136-790-7	Suspension Bail	1	69	910-976-0	DC Power Board Assembly	1	103	910-629-0	Breaker Unit (100/115V)	1
34	136-791-7	Suspension Bail Base	1	70	910-967-0	Connector Wire	1				
35	944-213-0	Supporting Ring (12 x 16 x 1)	1	71	910-676-0	Electric Motor L=30	1				
36	945-000-0	Allen Head Bolt (M3 x 8)	2	72	098-174-4	Switch Assembly	1				

### FOOTNOTES



10000 SE PINE  
PORTLAND, OR 97216  
503-254-6600  
FAX 503-255-2615

When ordering spare parts, please specify  
tool type, part number, and description.