

UDBP-T50 SERIES BATTERY OIL-PULSE TOOLS

EXPLODED VIEW

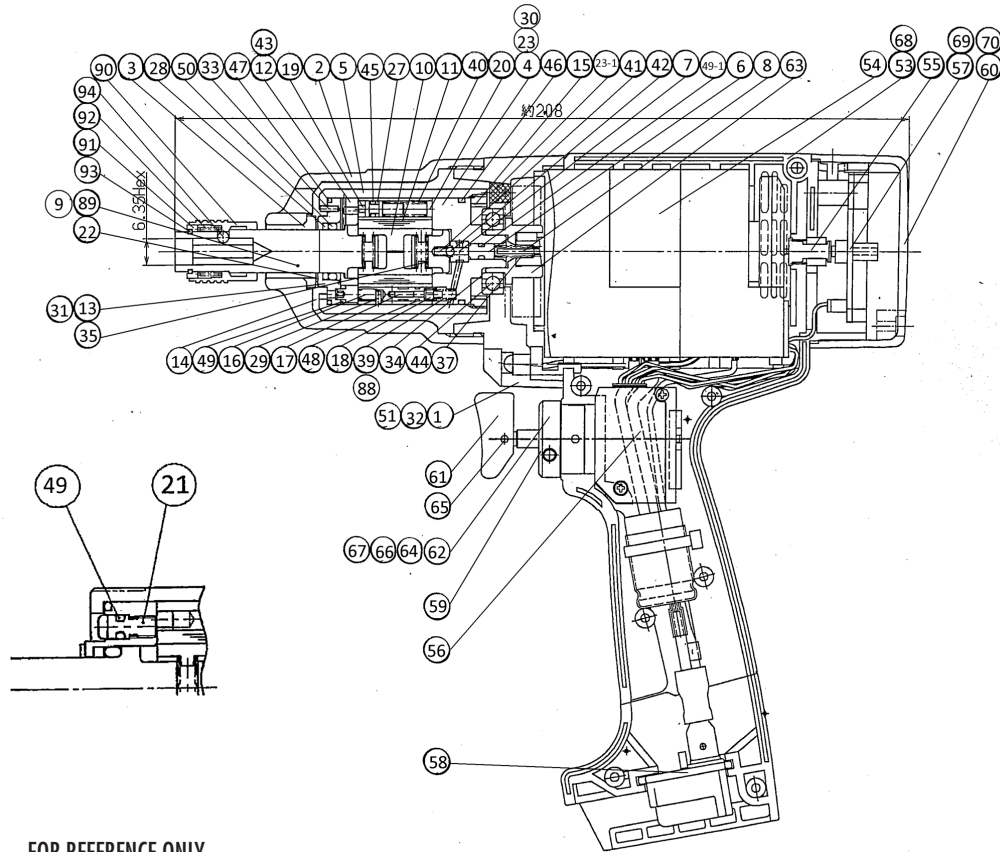

PARTS LIST — FOR REFERENCE ONLY

Index Number	Part Number	Description	Qty.	Index Number	Part Number	Description	Qty.	Index Number	Part Number	Description	Qty.
1	093-065-8	Handle Front Plate	1	29	970-013-0	Pin(H) 1.5 x 4	1	55	861-173-1	Slide Base Assembly	1
2	093-439-8	Front Casing	1	30	970-130-0	Pin(H) 2.45 x 4.5	2	56	861-174-1	Switch Assembly	1
3	190-328-6	Anvil Bushing	1	31	970-131-0	Pin(H) 2.45 x 9.5	2	57	863-972-1	Operating Board	1
4	145-901-0	Rear Liner Plate	1	32	962-006-0	Spring Washer	4	58	861-193-1	Battery Contact	1
5	145-902-0	Liner	1	33	973-040-0	Roller Pin 1.5 x 5	2	59	861-177-1	Sleeve	1
6	145-546-6	Piston	1	34	975-752-0	Adjusting Spacer 15 x 10 x t	1	60	861-178-1	Handle Cover	1
7	145-929-6	Chack Valve Cover	1	35	976-805-0	Spring 3.5 x 25.2 (0.4) WPC	2 ■	61	147-107-2	Valve Lever	1
8	092-130-8	Operation Rod 1.4 x 82.7	1	37	976-628-0	Spring 3.3 x 13 (0.5) N=10.5	1	62	098-212-5	Reverse Lever	1
9	145-319-0	Anvil	1 ●	39	976-848-0	Spring 2.8 x 7.1 (0.4) N=5.75	1 ● ■	63	863-956-1	Coupling	1
10	145-440-0	Driving Blade	2	40	976-674-0	Spring 4.3 x 14 (0.55)	1 ■	64	954-105-0	Screw M4 x 5	1
11	145-974-0	Roller 2.5 x 21	2	41	976-645-0	Spring 2.4 x 5 (0.3)	1 ■	65	973-014-0	Rpller Pin 2 x 14	1
12	145-973-6	Liner Casing Spacer	1	42	981-001-0	Ball 3/32	1	66	976-006-0	Spring 3 x 5 (0.4)	1
13	094-904-4	Front Liner Plate	1	43	981-045-0	Ball 1.5 mm	1	67	981-002-0	Ball 1/8	1
14	145-905-0	Liner Casing	1	44	982-902-0	Ball Bearing 6901	1	68	861-179-1	Screw	7
15	145-906-6	Liner Casing Cover	1	45	990-320-0	O-Ring ARP568-003	1 ■	69	861-180-1	Screw	2
16	145-907-6	Relief Valve Spindle	1	46	990-329-0	O-Ring JW1530-19	1 ■	70	861-181-1	Screw	2
17	093-970-8	Relief Valve	1	47	990-605-0	O-Ring 25 x 1.45	1 ■				
18	144-270-0	Pressure Regulating Valve	1	48	990-621-0	O-Ring 3.8 x 1.8 x 1.0	1 ■	88	976-849-0	Spring 2.8 x 7 (0.4) N=6.5	1
19	145-972-6	Accumulator	1	49	990-900-0	O-Ring SNS-2	2 ■	89	145-350-2	Driver Anvil	1
20	145-908-7	Accumulator Cover	1	49-1	990-305-0	O-Ring ARP568-003 (KS)	1 ■	90	011-351-1	Bit Sleeve	1
21	194-742-0	Oil Plug	1	50	991-030-0	X-Ring	1 ■	91	011-352-1	Bit Spacer	1
22	145-327-7	Anvil Front Spacer	1	51	963-363-0	Tapping Screw M4 x 35 (H)	4	92	976-327-0	Spring 13.5 x 11 (0.9)	1
23	150-064-5	Plug	1					93	978-117-0	Snap Ring 11.7 x 1	1
23-1	080-835-3	Filter	3					94	981-002-0	Ball 1/8	1
27	944-002-0	Supporting Ring 2.6 x 4.5 x 1	1 ■	Handle Assembly 863-968-1							
28	944-213-0	Supporting Ring 12 x 16 x 1	1 ■	53	863-958-1	Handle	1				
				54	861-192-1	Motor Assembly	1				

FOOTNOTES

- = Parts for UDBP-T50(P)
- = Items in Pulse Repair Kit UDBP-T50-PRK



10000 SE PINE
PORTLAND, OR 97216
503-254-6600
FAX 503-255-2615

When ordering spare parts, please specify
tool type, part number, and description.