

UAT-60S, 60SD SERIES OIL-PULSE WRENCHES

EXPLODED VIEW

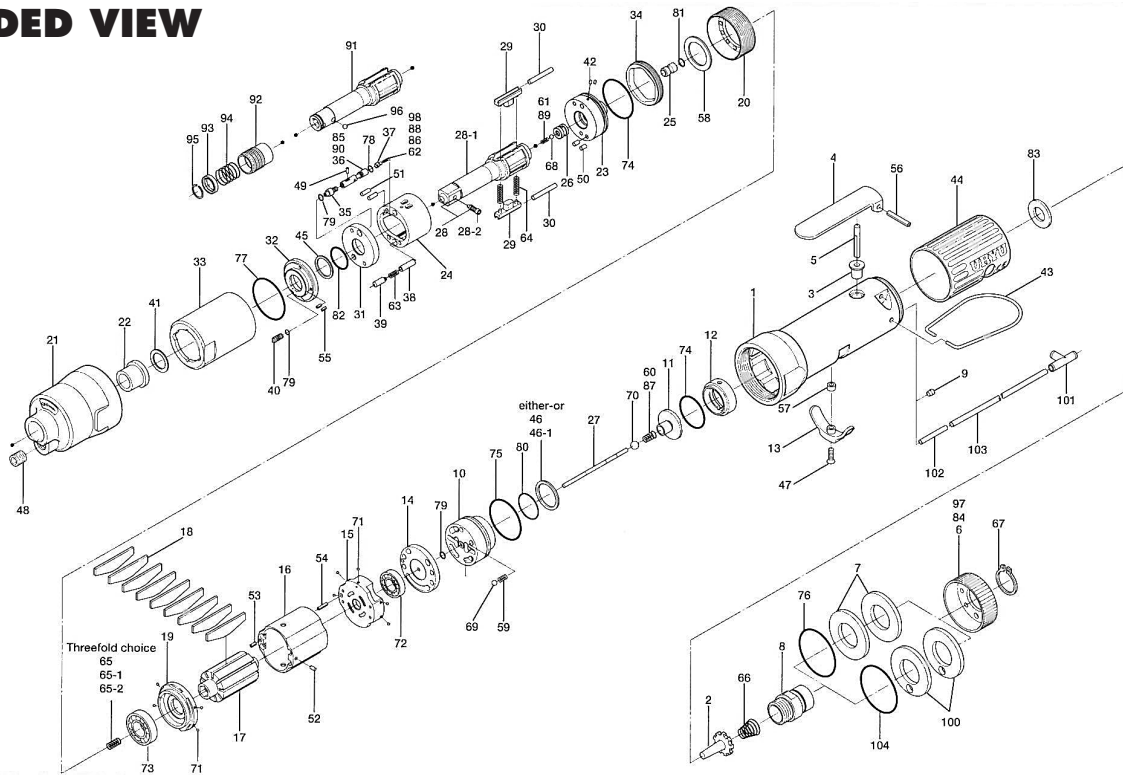

PARTS LIST — FOR REFERENCE ONLY

Index Number	Part Number	Description	Qty.	Index Number	Part Number	Description	Qty.	Index Number	Part Number	Description	Qty.
1	180-025-8	Casing	1	39	080-276-6	Pressure Valve Body	1	75	990-331-0	O-Ring (JW1530-21)	1
2	259-100-0	Valve	1	40	194-742-0	Oil Plug	1	76	990-603-0	O-Ring (28.5 x 1.3)	1
3	161-103-3	Valve Rod Bushing	1	41	145-327-7	Anvil Front Spacer	1	77	990-605-0	O-Ring (25 x 1.45)	1 ●▲
4	180-107-8	Valve Lever	1	42	150-064-5	Plug	2	78	990-621-0	O-Ring (3.8 x 1.8 x 1.0)	1 ●▲
5	128-104-8	Valve Rod	1	43	191-790-1	Suspension Ring	1	79	990-970-0	O-Ring (SNS-2)	3 ●▲
6	128-782-8	Exhaust Cover	1	44	129-842-3	Casing Cover	1	80	990-914-0	O-Ring (SNS-16)	1
7	128-835-8	Filter (K200)	2 ■	45	944-212-0	Back-up Ring (12 x 16 x 1.5)	1 ●▲	81	990-305-0	O-Ring (ARP568-003)	1 ●▲
8	128-091-8	Air Inlet Bushing	1	46	944-216-0	Back-up Ring (14 x 20 x 1.85)	1	82	992-020-0	SU-Ring (Q12)	1 ●▲
9	147-064-6	Filler	1	46-1	944-218-0	Back-up Ring (14 x 20 x 1.9)	1	83	996-424-0	Urethane Packing (16 x 9 x 2)	1
10	129-253-2	Shut-off Valve Bushing	1	47	948-426-0	Allen Head Dog Point Screw (M3 x 12)	1	84	129-782-0	Exhaust Deflector	1
11	145-254-6	Shut-off Valve	1	48	966-099-0	Allen Head Plug (NPT1/16)	1	85	094-970-4	Relief Valve	1
12	129-684-2	Cushion Spacer	1	49	970-013-0	Pin(H)(1.5 x 4)	1	86	976-882-0	Spring (2.7 x 7.5)	1
13	161-212-3	Reverse Lever	1	50	970-130-0	Pin (H)(2.45 x 4.5)	2	87	976-687-0	Spring (4.3 x 10)	1
14	128-291-8	Rear Plate Spacer	1	51	970-131-0	Pin (H)(2.45 x 9.5)	2	88	976-676-0	Spring (2.7 x 7.4)	1 ▲
15	129-285-2	Rear Plate	1	52	971-102-0	Pin (2 x 3.8)	1	89	976-626-0	Spring (2.4 x 6)	1 ▲
16	129-286-2	Cylinder	1	53	973-008-0	Roll Pin (2 x 8)	1	90	094-970-4	Relief Valve	1
17	145-287-6	Rotor	1	54	973-018-0	Roll Pin (2 x 18)	1	91	145-350-7	Driver Anvil	1
18	147-288-2	Blade (PC)	9 ■	55	973-040-0	Roll Pin (1.5 x 5)	2	92	011-351-1	Bit Sleeve	1
19	128-289-8	Front Plate	1	56	973-122-0	Roll Pin (3 x 22)	1	93	011-352-1	Bit Spacer	1
20	147-036-2	Hammer Casing Connector	1	57	975-004-0	Spacer (5.5 x 3.1 x 2.7)	1	94	976-327-0	Spring (13.5 x 11)	1
21	145-439-7	Front Casing	1	58	975-752-0	Adjusting Spacer (15 x 10 x 1)	1	95	978-117-0	Snap Ring (11.7 x 1)	1
22	190-328-6	Anvil Bushing	1	59	976-006-0	Spring (3 x 5)	1	96	981-002-0	Ball (1/8)	1
23	18C-901-8	Rear Liner Plate	1	60	977-045-0	Cone Spring (4 x 4.6 x 9)	1	PARTS FOR UAT-60SDL			
24	080-902-6	Liner	1	61	976-645-0	Spring (2.4 x 5)	1 ●▲	97	129-782-0	Exhaust Deflector	1
25	145-546-6	Piston	1	62	976-856-0	Spring (2.8 x 7.4)	1 ●▲	98	976-883-0	Spring (2.7 x 7.6)	1
26	145-929-6	Check Valve Cover	1	63	976-841-0	Spring (3 x 11.4)	1 ●▲	PARTS FOR UAT-60S (TM) TYPE			
27	129-130-2	Operating Rod (2.1 x 64.7)	1	64	976-792-0	Spring (3.5 x 21) WPC	2 ●▲	Remove 9 147-064-6 Filler			
28	891-552-1	Anvil Assembly (P)	1	65	976-650-0	Spring (3.3 x 16) Standard	1	100	851-053-1	Filter (K200)	1
28-1	145-319-6	Anvil	1	65-1	976-662-0	Spring (3.3 x 17.5) Strong	1	101	909-442-0	Quick Exhaust (AQ240F-04-00)	1
28-2	891-300-1	Socket Pin Assembly	1	65-2	976-857-0	Spring (3.3 x 17.5) Medium	1	102	935-240-0	Nylon Tube (18NY)	1
29	145-440-6	Driving Blade	2	66	977-227-0	Cone Spring (9 x 12 x 25)	1	103	935-350-0	Polyurethane Hose (F-1504)	1
30	145-974-6	Roller (2.5 x 26)	2	67	979-358-0	SnapRing (ISTW-17)	1	104	990-333-0	O-Ring (JW1530-23)	1
31	18C-973-8	Liner Casing Setter	1	68	981-001-0	Ball (3/32)	1	ACCESSORIES			
32	145-904-6	Front Liner Plate	1	69	981-002-0	Ball (1/8)	1	110	939-091-0	Allen Wrench (1.5)	1
33	145-905-6	Liner Casing	1	70	981-003-0	Ball (5/32)	1	111	939-105-0	Allen Wrench (4)	1
34	145-906-6	Liner Casing Cover	1	71	981-045-0	Ball (1.5)	9	114	909-449-0	Speed Controller	1
35	145-907-6	Relief Valve Spindle	1	72	982-014-0	Ball Bearing (607)	1 ■	FOOTNOTES			
36	145-970-7	Relief Valve	1	73	982-902-0	Ball Bearing (6901)	1 ■	● = Items in Pulse Repair Kit UAT-60S-PRK			
37	144-270-0	Pressure Valve	1	74	990-329-0	O-Ring (JW1530-19)	2 ●▲	■ = Items in Pulse Repair Kit UAT-60SD-RK			
38	080-274-6	Pressure Valve Spring Collar	1					▲ = Items in Pulse Repair Kit UAT-60SD-PRK			



10000 SE PINE
PORTLAND, OR 97216
503-254-6600
FAX 503-255-2615

When ordering spare parts, please specify
tool type, part number, and description.

FOOTNOTES

- = Items in Pulse Repair Kit UAT-60S-PRK
- = Items in Pulse Repair Kit UAT-60SD-RK
- ▲ = Items in Pulse Repair Kit UAT-60SD-PRK

UAT-60S-PRK

(Kit contains following parts)

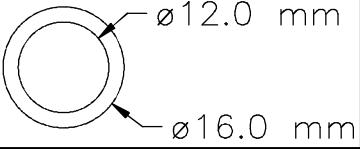
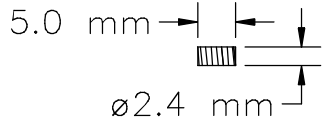
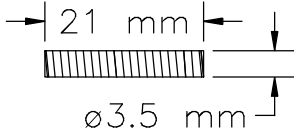
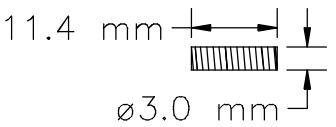
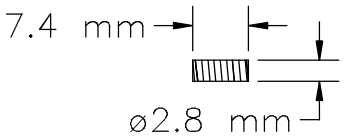
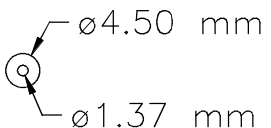
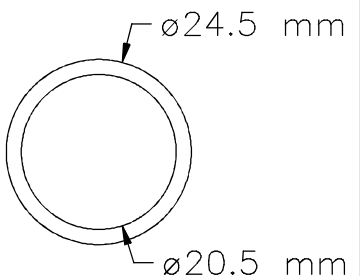
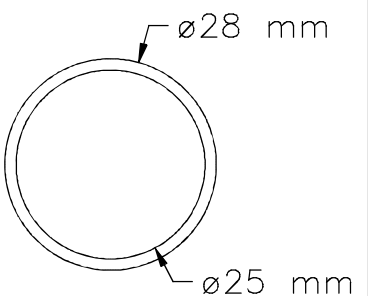
#/#	Bin Location	Part Number	QTY	Description	Material	Drawing / Scketch
1	PA10	944-212-0	1	Supporting Ring 12x16x1.5	Teflon-White	
2	PA1I	976-645-0	1	Spring 2.4x5	Spring wire ø.32 mm	
3	PA1J	976-792-0	2	Spring 3.5x21 (0.45)WPC	Spring wire ø.45 mm	
4	PA4G	976-841-0	1	Spring 3.0 X 11.4	Spring wire ø.40 mm	
5	PA4G	976-856-0	1	Spring 2.8x7.4(0.55)	Spring wire ø.55 mm	
6	PA1A	990-305-0	1	O-Ring 4.5X1.37X1.7	Buna-Black	
7	PA1D	990-329-0	1	O-Ring 24.5x20.5x1.8	Buna-Black	
8	PA1A	990-605-0	1	O-Ring 25x28x1.45	Buna-Black	

UAT-60S-PRK

(Kit contains following parts)

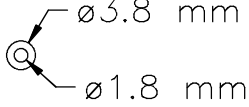
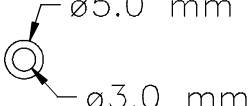
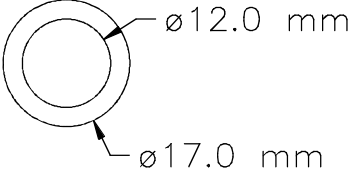
#/#	Bin Location	Part Number	QTY	Description	Material	Drawing / Scketch
9	PA1A	990-621-0	1	O-Ring 3.8X1.8X1	Buna-Black	 <p>∅3.8 mm ∅1.8 mm</p>
10	PA1C	990-970-0	2	O-Ring (SNS-2)	Buna-Black	 <p>∅5.0 mm ∅3.0 mm</p>
11	PA10	992-020-0	1	SU-Ring (Q-12) (NTN)	Buna-Black	 <p>∅12.0 mm ∅17.0 mm</p>

UAT-60SD-RK

(Kit contains following parts)

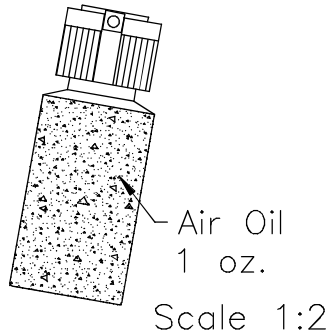
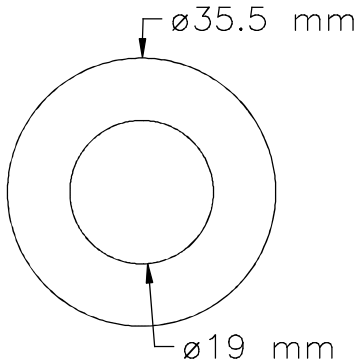
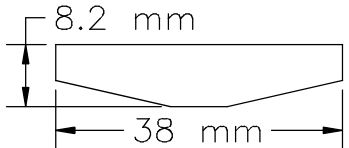
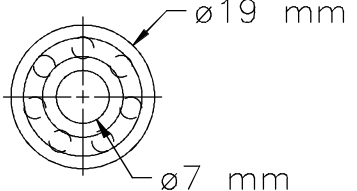
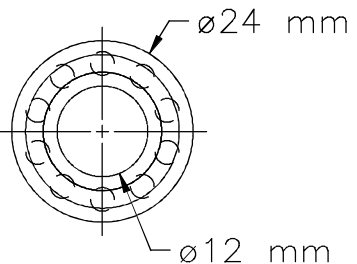
#/#	Bin Location	Part Number	QTY	Description	Material	Drawing / Scketch
1	SEWALL	AM-OIL	1	Oil Air Motor 1 oz. fluid	Plastic Container	
2	PA3A	128-835-8	2	Filter K200 19x35.5x3.1	Sendered Plastic	
3	PA2B	147-288-2	9	Blade(PC) 8.2x38x1.65	Phenolic-Fiber	
4	PA2H	982-014-0	1	Ball Bearing(607) 7x19x6	Bearing Steel	
5	PA2I	982-902-0	1	Ball Bearing(6901) 12x24x6	Bearing Steel	

UAT-60SD-PRK

(Kit contains following parts)

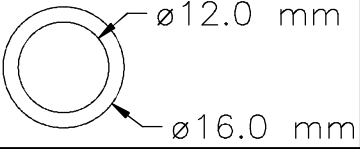
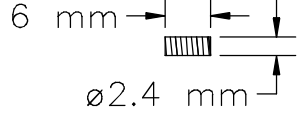
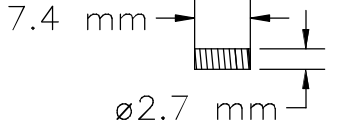
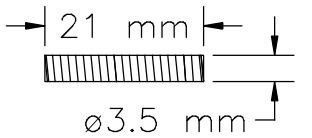
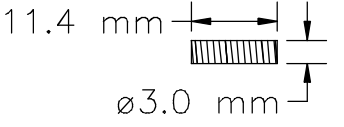
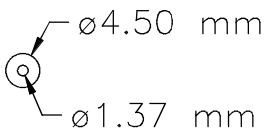
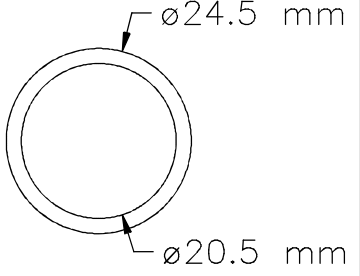
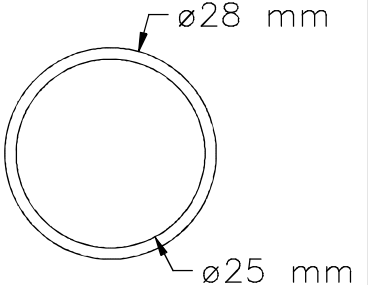
#/#	Bin Location	Part Number	QTY	Description	Material	Drawing / Scketch
1	PA10	944-212-0	1	Supporting Ring 12x16x1.5	Teflon-White	
2	PA10	976-626-0	1	Spring 2.4x6	Spring wire ø.26 mm	
3	PA1I	976-676-0	1	Spring 2.7x7.4	Spring wire ø.45 mm	
4	PA1J	976-792-0	2	Spring 3.5x21 (0.45)WPC	Spring wire ø.45 mm	
5	PA4G	976-841-0	1	Spring 3.0 X 11.4	Spring wire ø.40 mm	
6	PA1A	990-305-0	1	O-Ring 4.5X1.37X1.7	Buna-Black	
7	PA1D	990-329-0	1	O-Ring 24.5x20.5x1.8	Buna-Black	
8	PA1A	990-605-0	1	O-Ring 25x28x1.45	Buna-Black	

UAT-60SD-PRK

(Kit contains following parts)

#/#	Bin Location	Part Number	QTY	Description	Material	Drawing / Scketch
9	PA1A	990-621-0	1	O-Ring 3.8X1.8X1	Buna-Black	
10	PA1C	990-970-0	2	O-Ring (SNS-2)	Buna-Black	
11	PA10	992-020-0	1	SU-Ring (Q-12) (NTN)	Buna-Black	