

Signature Series SPT-A1638 CORDLESS TRANSDUCERIZED TOOL

EXPLODED VIEW

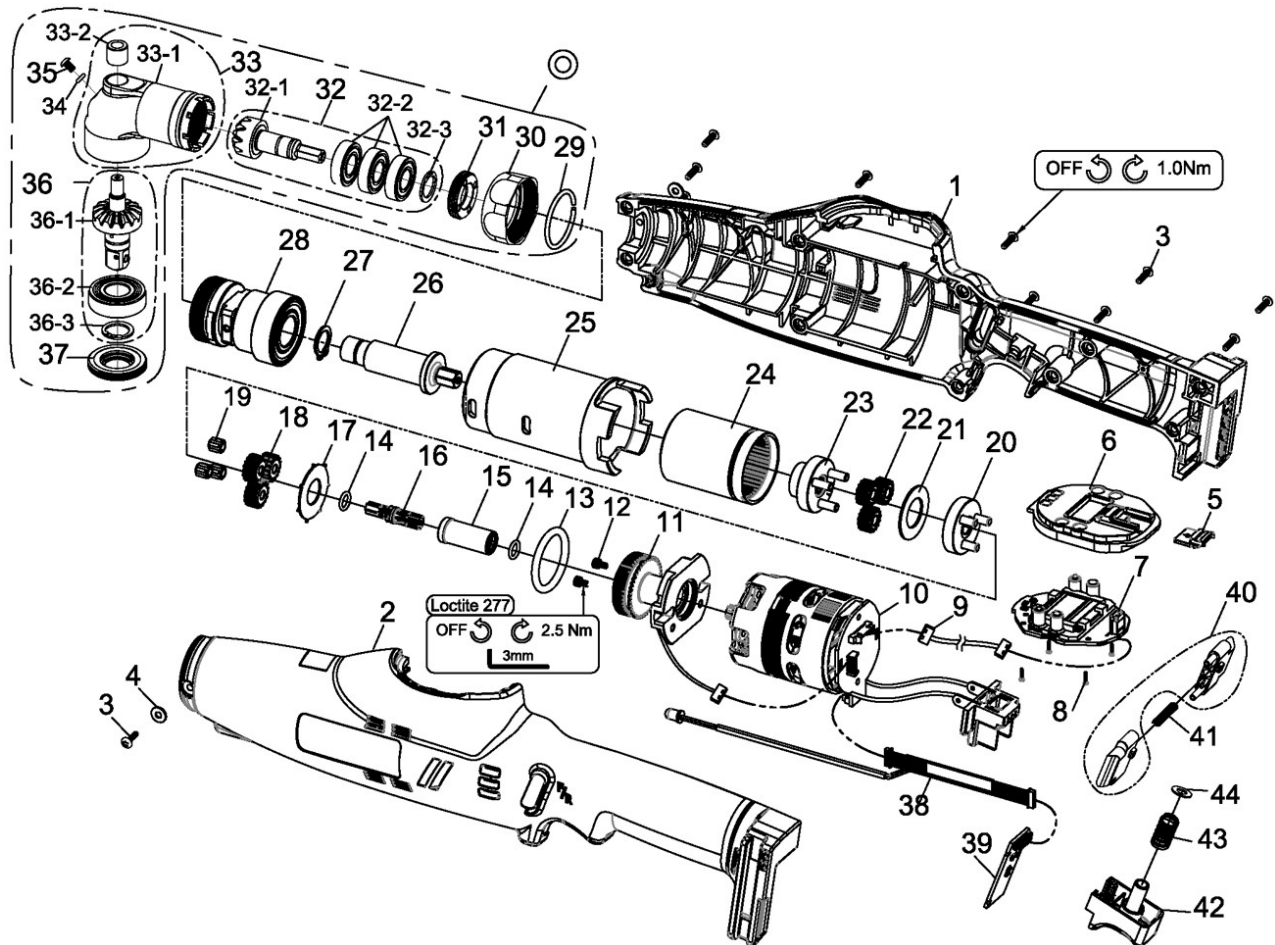

PARTS LIST — FOR REFERENCE ONLY

Index Number	Part Number	Description	Qty.	Index Number	Part Number	Description	Qty.	Index Number	Part Number	Description	Qty.
1	33101-NRA	Upper Housing	1	20	32051-WRBA-10	Gear Cage Assembly	1	33	32042-WRCA-03	Angle Housing Assembly	1
2	33102-NRA	Lower Housing	1	21	D39WR-8	Washer	1	33-1	33242-WRCA-05	Angle Housing	1
3	000-1430C	Screw (M3 x P0.5 x 10L)	14	22	D49WR-9	Planet Gear	3	33-2	0-211005	Needle Bearing (BKO609)	1
4	000-1531B	Washer (3.3 x 8)	2	23	32051-NRA-02	Gear Plate Assembly	1	34	0-451019	O-Ring (2 x 1.5)	1
5	33110-NPA-02	Cover	1	24	32049-NRA-01	Gear Ring Assembly	1	35	0-121002	Screw (M3 x 5L)	1
6	33110-NRA-03	Cover	1	25	33251-NRA-02	Retaining Seat	1	36	32049-WRBA-S3-03	Bevel Gear Assembly	1
7	32076-NRA-01	LCM Board Assembly	1	26	33243-NRA-01	Shaft	1	36-1	32049-WRBA-S3-04	Bevel Gear	1
8	0-151018	Screw (2.6 x 6L)	4	27	000-3012	Snap Ring (STW-12)	1	36-2	0-201033-1	Ball Bearing (6001-2RSH)	1
9	B86PW35	Connector Wire	1	28	32051-NRA-05	Connecting Holder Assembly	1	36-3	0-331003	Inverted Retaining Ring (ISTW-12)	1
10	32083-NRA-03	Brushless Motor w/driver	1	©	32042-WRCA-S3-03	Angle Housing Units	1	37	D54WR108B-2B	Lock Nut	1
11	32046-NRA-03	Transducer Assembly	1	29	D44WR108B	Collar	1	38	33386-NRA-01	LED Wire Set	1
12	0-101066	Screw (M4 x 11L)	2	30	D54WR108B#BZ	Lock Nut	1	39	E76WR	PC Board	1
13	0-431022	O-Ring (P26)	1	31	D54WR108B-1B	Lock Nut	1	40	B09PW15-1#B1	F/R Valve (1 set x 2 pcs)	1
14	00-41255	O-Ring (S7)	2	32	32049-WRBA-02	Main Bevel Gear Assembly	1	41	D48PW15-1	Spring	1
15	33242-NRA-01	Sleeve Coupling	1	32-1	33249-WRBA-16	Main Bevel Gear	1	42	B09PW15#B1	Trigger Assembly	1
16	33249-NRA-04	Sun Gear	1	32-2	0-201023-1	Ball Bearing(6900ZZ)	3	43	D48PW15	Spring	1
17	D39SCT80B-4	Washer	1	32-3	0-331002	Inverted Retaining Ring (ISTW-10)	1	44	C39PW15-3	Washer	1
18	D49WRB-9	Planet Gear	3								
19	000-2415	Needle Bearing (INA-K357)	3								



10000 SE PINE
PORTLAND, OR 97216
503-254-6600
FAX 503-255-2615

When ordering spare parts, please specify
tool type, part number, and description.

FOOTNOTES